

A Word to Mazda Owners

Thank you for choosing a Mazda product. We at Mazda design and build vehicles with complete customer satisfaction in mind.

To help ensure enjoyable and trouble-free operation of your Mazda vehicle, read this manual carefully and follow its recommendations.

Regular servicing of your vehicle by an expert technician helps maintain both its roadworthiness and its resale value. A world-wide network of Authorised Mazda Repairer can help you with their professional servicing expertise. Their specially trained personnel are best qualified to service your Mazda vehicle properly and precisely to original specifications. Also, they are supported by a wide range of highly specialized tools and equipment specially developed for servicing Mazda vehicles. When maintenance or service is necessary, consult an expert repairer (we recommend an Authorised Mazda Repairer).

We assure you that all of us at Mazda have an ongoing interest in your motoring pleasure and in your full satisfaction with your Mazda product.

Mazda Motor Corporation
HIROSHIMA, JAPAN

Important Notes About This Manual

Keep this manual in the glove compartment as a handy reference for the safe and enjoyable use of your Mazda vehicle. Should you resell the vehicle, leave this manual with it for the next owner.

All specifications and descriptions are accurate at the time of printing. Because improvement is a constant goal at Mazda, we reserve the right to make changes in specifications at any time without notice and without obligation.

Please be aware that this manual applies to all models, equipment and options. As a result, you may find some explanations for equipment not installed on your vehicle.

©2022 Mazda Motor Corporation
November 2022(Print1)

How to Use This Manual

We want to help you get the most driving pleasure from your vehicle. Your owner's manual, when read from beginning to end, can do that in many ways.

Illustrations complement the words of the manual to best explain how to enjoy your Mazda. By reading your manual, you can find out about the features, important safety information, and driving under various road conditions.

You'll find several **WARNINGS**, **CAUTIONS**, and **NOTES** in the manual.



A **WARNING** indicates a situation in which serious injury or death could result if the warning is ignored.



A **CAUTION** indicates a situation in which bodily injury or damage to your vehicle, or both, could result if the caution is ignored.

NOTE

A **NOTE** provides information and sometimes suggests how to make better use of your vehicle.

The symbol below in this manual means "Do not do this" or "Do not let this happen".



The following symbol indicates the operation, such as a push or a turn.

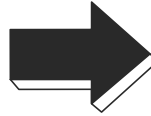

The following symbol indicates the order of the operation, such as a push or a turn.

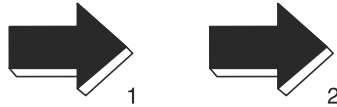

The following symbol indicates the location of parts.

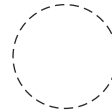

The following symbol indicates a change of status.

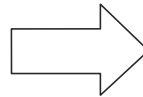

The following symbol, located on some parts of the vehicle, indicates that this manual contains information related to the part.

Please refer to the manual for a detailed explanation.



References to left hand and right hand are made as if facing in the same direction the vehicle faces. Although this manual explains a left-hand-drive model, it also applies to right-hand-drive models.

Index: A good place to start is the Index, an alphabetical listing of all information in your manual.

MEMO

Table of Contents

Name of Each Part	1
Read This First	2
Equipment to Protect Occupants/Pedestrians	3
Opening/closing	4
Driving	5
Equipment to Make Cabin More Comfortable	6
Other Equipment	7
What to Do in Case of Emergency	8
Inspection and Servicing/Cleaning	9
Specifications/Customer Information	10
Index	11

1

Name of Each Part

Steering Wheel Area

Overview.....	1-2
Steering Wheel Area Overview (Left-Hand Drive Model).....	1-2
Steering Wheel Area Overview (Right-Hand Drive Model).....	1-3

Driver's Seat Area Overview..... 1-4

Driver's Seat Area Overview (Left-Hand Drive Model).....	1-4
Driver's Seat Area Overview (Right-Hand Drive Model).....	1-5

Instrument Panel Area

Overview.....	1-6
Instrument Panel Area Overview (Left-Hand Drive Model).....	1-6
Instrument Panel Area Overview (Right-Hand Drive Model).....	1-7

Front Cabin Overview..... 1-8

Front Cabin Overview (Left-Hand Drive Model).....	1-8
Front Cabin Overview (Right-Hand Drive Model).....	1-9

Rear Cabin Overview..... 1-10

Rear Cabin Overview (Left-Hand Drive Model).....	1-10
Rear Cabin Overview (Right-Hand Drive Model).....	1-11

Luggage Compartment

Overview.....	1-12
Luggage Compartment Overview.....	1-12

Front Exterior Overview..... 1-13

Front Exterior Overview.....	1-13
------------------------------	------

Rear Exterior Overview..... 1-14

Rear Exterior Overview.....	1-14
-----------------------------	------

Steering Wheel Area Overview

Steering Wheel Area Overview (Left-Hand Drive Model)

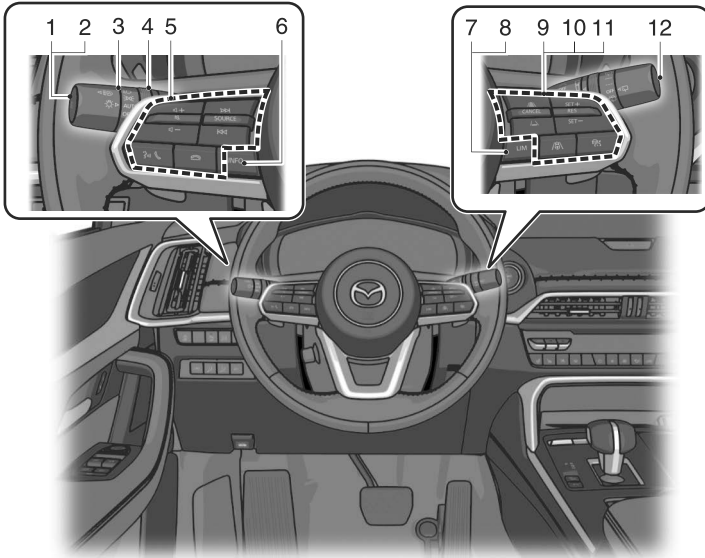

- ① High Beam Control System (HBC) switch..... page 5-148
- ② Adaptive LED Headlights (ALH) switch..... page 5-153
- ③ Lighting control..... page 5-79
- ④ Turn and lane-change signals..... page 5-83
- ⑤ Audio remote control switches..... page 7-12
- ⑥ INFO switch..... page 5-27
- ⑦ Adjustable Speed Limiter (ASL) LIM switch..... page 5-215
- ⑧ Intelligent Speed Assistance (ISA) LIM switch..... page 5-218
- ⑨ Mazda Radar Cruise Control (MRCC) switches..... page 5-181
- ⑩ Cruising & Traffic Support (CTS) switches..... page 5-194
- ⑪ Cruise control switches..... page 5-255
- ⑫ Wiper and washer lever..... page 5-85

Steering Wheel Area Overview

Steering Wheel Area Overview (Right-Hand Drive Model)

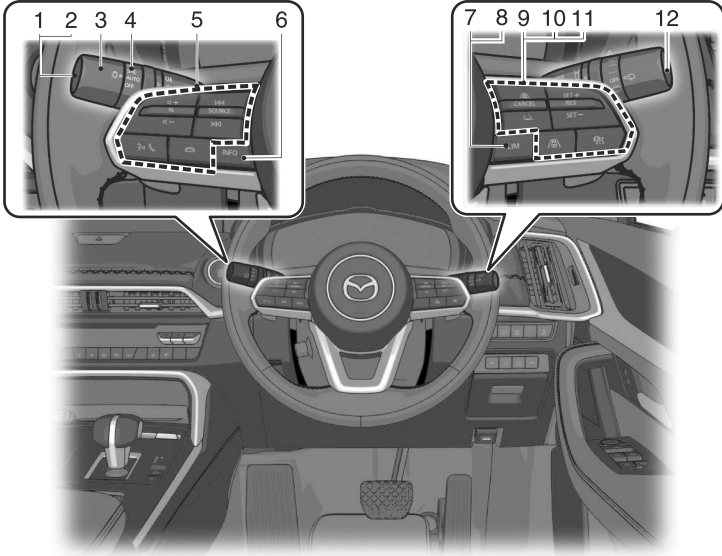

- ① High Beam Control System (HBC) switch..... page 5-148
- ② Adaptive LED Headlights (ALH) switch..... page 5-153
- ③ Lighting control..... page 5-79
- ④ Turn and lane-change signals..... page 5-83
- ⑤ Audio remote control switches..... page 7-12
- ⑥ INFO switch..... page 5-27
- ⑦ Adjustable Speed Limiter (ASL) LIM switch..... page 5-215
- ⑧ Intelligent Speed Assistance (ISA) LIM switch..... page 5-218
- ⑨ Mazda Radar Cruise Control (MRCC) switches..... page 5-181
- ⑩ Cruising & Traffic Support (CTS) switches..... page 5-194
- ⑪ Cruise control switches..... page 5-255
- ⑫ Wiper and washer lever..... page 5-85

Driver's Seat Area Overview

Driver's Seat Area Overview (Left-Hand Drive Model)

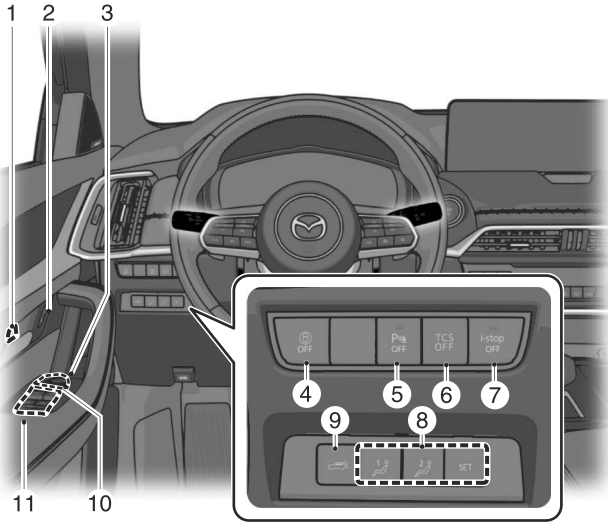

① Door-lock knob.....	page 4-12
② Door-lock switch.....	page 4-12
③ Outside mirror switches.....	page 5-11
④ i-ACTIVSENSE OFF switch.....	page 5-132
⑤ Parking sensor OFF switch.....	page 5-264
⑥ TCS OFF switch.....	page 5-97
⑦ i-stop OFF switch.....	page 5-23
⑧ Position memory buttons.....	page 3-28
⑨ Power liftgate switch.....	page 4-21
⑩ Power window switches.....	page 4-29
⑪ Power window lock switch.....	page 4-29

Driver's Seat Area Overview

Driver's Seat Area Overview (Right-Hand Drive Model)

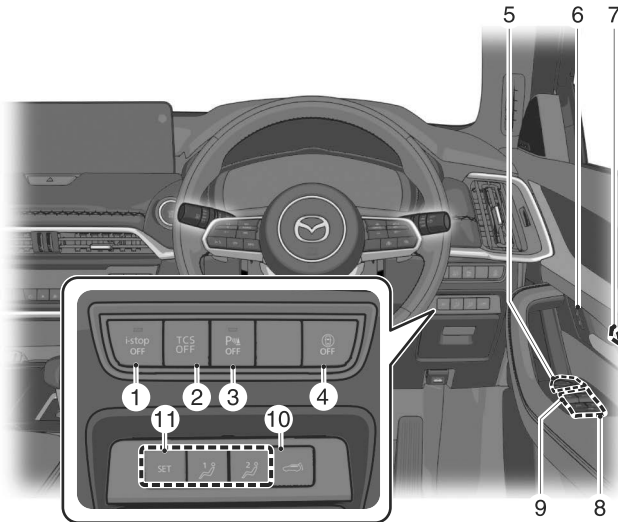

① i-stop OFF switch.....	page 5-23
② TCS OFF switch.....	page 5-97
③ Parking sensor OFF switch.....	page 5-264
④ i-ACTIVSENSE OFF switch.....	page 5-132
⑤ Door-lock knob.....	page 4-12
⑥ Door-lock switch.....	page 4-12
⑦ Power window switches.....	page 4-29
⑧ Power window lock switch.....	page 4-29
⑨ Outside mirror switches.....	page 5-11
⑩ Power liftgate switch.....	page 4-21
⑪ Position memory buttons.....	page 3-28

Instrument Panel Area Overview

Instrument Panel Area Overview (Left-Hand Drive Model)

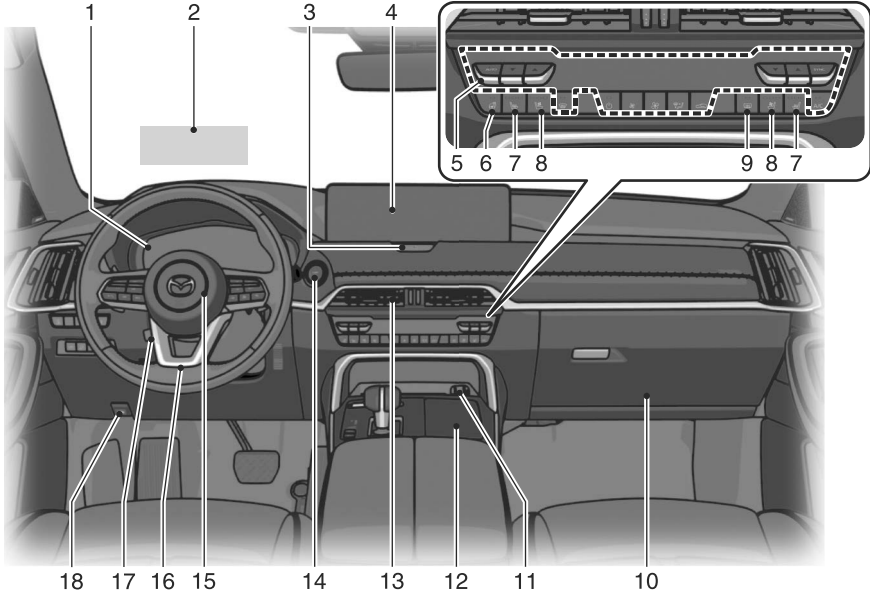

① Instrument cluster.....	page 5-26
② Active driving display.....	page 5-52
③ Hazard warning flasher switch.....	page 5-93
④ Mazda Connect.....	page 7-6
⑤ Air-conditioning system.....	page 6-6
⑥ Heated steering wheel switch.....	page 6-16
⑦ Seat warmer switches.....	page 6-13
⑧ Seat ventilation switches.....	page 6-18
⑨ Rear window defogger switch.....	page 5-90
⑩ Glove compartment.....	page 7-51
⑪ Accessory socket.....	page 7-65
⑫ Cup holder.....	page 7-49
⑬ Vent.....	page 6-2
⑭ Push button start.....	page 5-16
⑮ Horn.....	page 5-94
⑯ Lock release lever.....	page 3-39
⑰ Tilt and telescopic switch.....	page 3-39
⑱ Bonnet release handle.....	page 4-27

Instrument Panel Area Overview

Instrument Panel Area Overview (Right-Hand Drive Model)

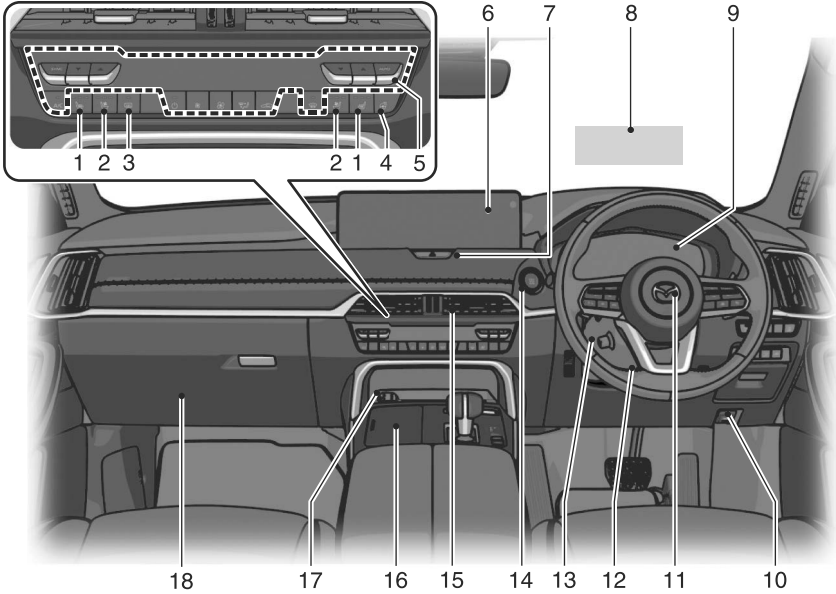

① Seat warmer switches.....	page 6-13
② Seat ventilation switches.....	page 6-18
③ Rear window defogger switch.....	page 5-90
④ Heated steering wheel switch.....	page 6-16
⑤ Air-conditioning system.....	page 6-6
⑥ Mazda Connect.....	page 7-6
⑦ Hazard warning flasher switch.....	page 5-93
⑧ Active driving display.....	page 5-52
⑨ Instrument cluster.....	page 5-26
⑩ Bonnet release handle.....	page 4-27
⑪ Horn.....	page 5-94
⑫ Lock release lever.....	page 3-39
⑬ Tilt and telescopic switch.....	page 3-39
⑭ Push button start.....	page 5-16
⑮ Vent.....	page 6-2
⑯ Cup holder.....	page 7-49
⑰ Accessory socket.....	page 7-65
⑱ Glove compartment.....	page 7-51

Front Cabin Overview

Front Cabin Overview (Left-Hand Drive Model)

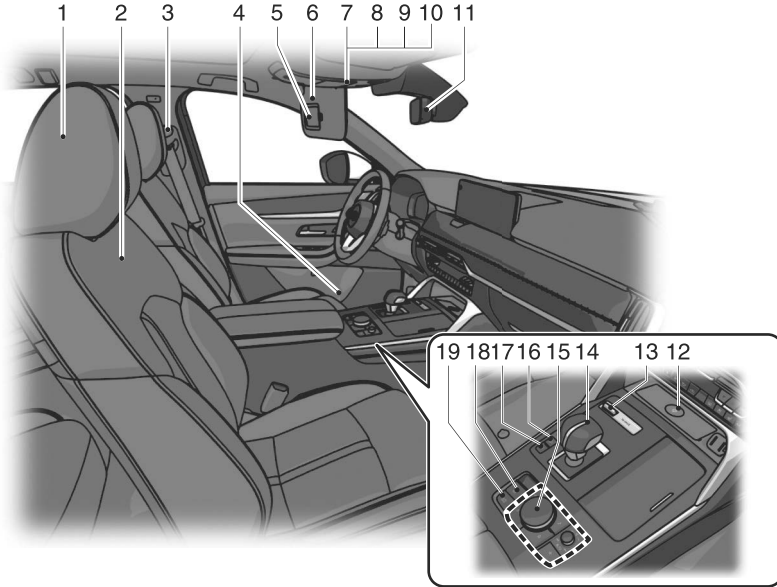

① Head restraint.....	page 3-37
② Front seat.....	page 3-25
③ Seat belt.....	page 3-21
④ Bottle holder.....	page 7-50
⑤ Vanity mirror.....	page 7-58
⑥ Sunvisor.....	page 7-57
⑦ Overhead light (front).....	page 7-60
⑧ Map lights.....	page 7-61
⑨ Overhead console.....	page 7-54
⑩ Panorama sunroof switch.....	page 4-32
⑪ Rearview mirror.....	page 5-14
⑫ Wireless Charger (Qi).....	page 7-72
⑬ Mazda intelligent Drive Select (Mi-Drive) switch.....	page 5-107
⑭ Selector lever.....	page 5-56
⑮ Commander switch.....	page 7-8
⑯ Hill descent control switch.....	page 5-104
⑰ 360° View Monitor switch.....	page 5-241
⑱ Electric Parking Brake (EPB) switch.....	page 5-68
⑲ AUTOHOLD switch.....	page 5-74

Front Cabin Overview (Right-Hand Drive Model)

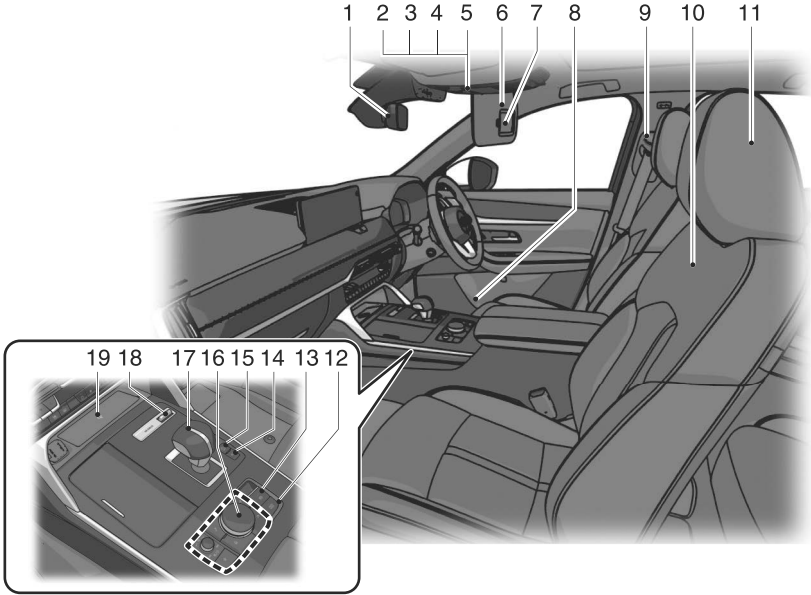

① Rearview mirror.....	page 5-14
② Overhead light (front).....	page 7-60
③ Map lights.....	page 7-61
④ Overhead console.....	page 7-54
⑤ Panorama sunroof switch.....	page 4-32
⑥ Sunvisor.....	page 7-57
⑦ Vanity mirror.....	page 7-58
⑧ Bottle holder.....	page 7-50
⑨ Seat belt.....	page 3-21
⑩ Front seat.....	page 3-25
⑪ Head restraint.....	page 3-37
⑫ AUTOHOLD switch.....	page 5-74
⑬ Electric Parking Brake (EPB) switch.....	page 5-68
⑭ 360° View Monitor switch.....	page 5-241
⑮ Hill descent control switch.....	page 5-104
⑯ Commander switch.....	page 7-8
⑰ Selector lever.....	page 5-56
⑱ Mazda intelligent Drive Select (Mi-Drive) switch.....	page 5-107
⑲ Wireless Charger (Qi).....	page 7-72

Rear Cabin Overview

Rear Cabin Overview (Left-Hand Drive Model)

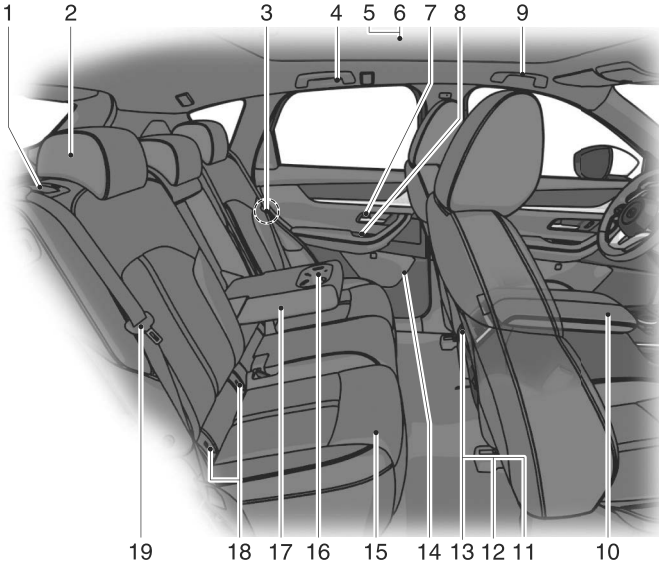

① Lever.....	page 3-32
② Head restraint.....	page 3-37
③ Child safety lock.....	page 4-12
④ Rear coat hook.....	page 7-55
⑤ Overhead light (rear).....	page 7-60
⑥ Map lights.....	page 7-61
⑦ Door-lock knob.....	page 4-12
⑧ Power window switch.....	page 4-29
⑨ Assist grip.....	page 7-74
⑩ Centre console.....	page 7-53
⑪ AC Power Outlet (220 V/150 W).....	page 7-67
⑫ USB Power Outlet.....	page 7-69
⑬ Seat warmer switches.....	page 6-13
⑭ Bottle holder.....	page 7-50
⑮ Rear seat.....	page 3-32
⑯ Cup holder.....	page 7-49
⑰ Armrest.....	page 3-35
⑱ ISOFIX lower anchors.....	page 3-49
⑲ Seat belt.....	page 3-21

Rear Cabin Overview (Right-Hand Drive Model)

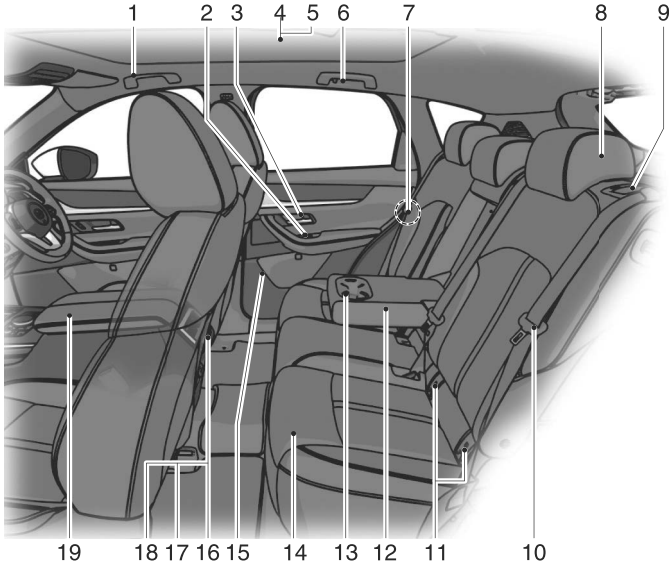

① Assist grip.....	page 7-74
② Power window switch.....	page 4-29
③ Door-lock knob.....	page 4-12
④ Overhead light (rear).....	page 7-60
⑤ Map lights.....	page 7-61
⑥ Rear coat hook.....	page 7-55
⑦ Child safety lock.....	page 4-12
⑧ Head restraint.....	page 3-37
⑨ Lever.....	page 3-32
⑩ Seat belt.....	page 3-21
⑪ ISOFIX lower anchors.....	page 3-49
⑫ Armrest.....	page 3-35
⑬ Cup holder.....	page 7-49
⑭ Rear seat.....	page 3-32
⑮ Bottle holder.....	page 7-50
⑯ Seat warmer switches.....	page 6-13
⑰ USB Power Outlet.....	page 7-69
⑱ AC Power Outlet (220 V/150 W).....	page 7-67
⑲ Centre console.....	page 7-53

Luggage Compartment Overview

Luggage Compartment Overview

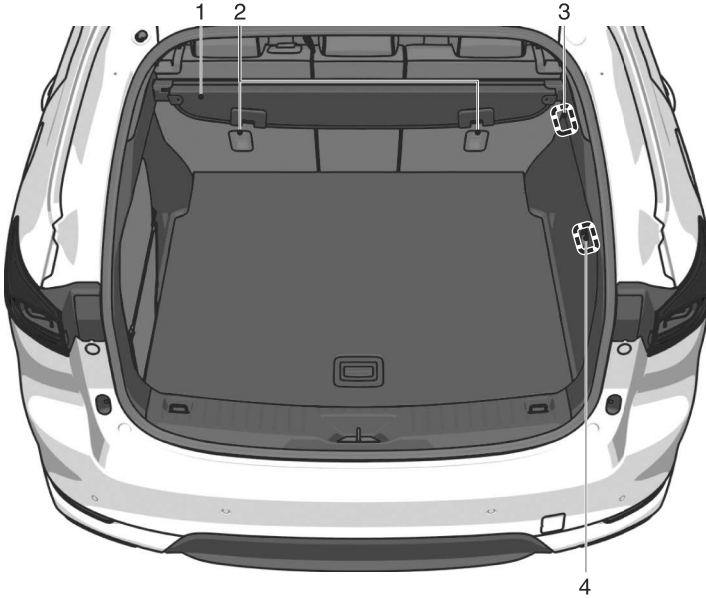

- ① Luggage compartment cover..... page 7-76
- ② Anchor bracket..... page 3-59
- ③ Luggage compartment lights..... page 7-62
- ④ Accessory socket..... page 7-65

Front Exterior Overview

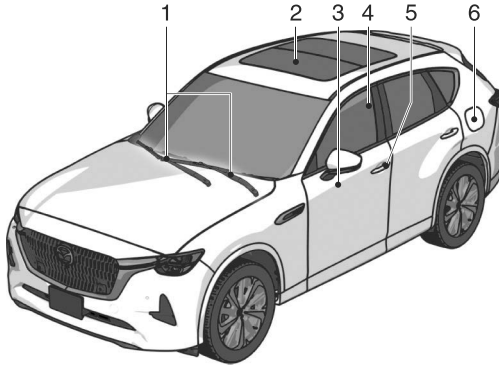

① Windscreen wiper blades.....	page 9-48
② Panorama sunroof.....	page 4-31
③ Door.....	page 4-11
④ Window.....	page 4-28
⑤ Touch sensor.....	page 4-12
⑥ Fuel-filler flap.....	page 5-120

Rear Exterior Overview

Rear Exterior Overview

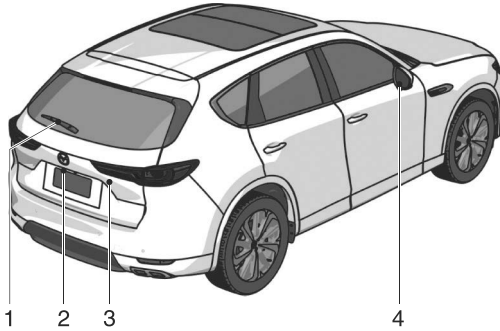

- ① Rear window wiper blade..... page 9-48
- ② Electric liftgate opener..... page 4-18
- ③ Liftgate..... page 4-17
- ④ Outside mirror..... page 5-10

2

Read This First

Things to Be Observed.....	2-2
Things to Be Observed While Driving.....	2-2
Things to Be Observed When Parking or Stopping.....	2-3

The Data Stored in The Vehicle.....	2-4
Data handling.....	2-4
A computer that records vehicle data.....	2-4

Open Source Software Information.....	2-5
Instrument Cluster (Type A).....	2-5
Active Driving Display.....	2-20
Driver Monitoring Camera.....	2-20
Cruising & Traffic Support (CTS).....	2-21

Things to Be Observed While Driving

WARNING

Never stop the engine when going down a hill.

Stopping the engine when going down a hill is dangerous. This causes the loss of power steering and power brake control, and may cause damage to the drivetrain. Any loss of steering or braking control could cause an accident.

Be extremely careful if it is necessary to downshift on slippery surfaces.

Downshifting into lower gear while driving on slippery surfaces is dangerous. The sudden change in tyre speed could cause the tyres to skid. This could lead to loss of vehicle control and an accident.

Avoid sharp turns, excessive speed and abrupt manoeuvres when driving this vehicle.

Sharp turns, excessive speed and abrupt manoeuvring of this vehicle are dangerous as it could result in the increased risk of loss of vehicle control, vehicle roll-over, personal injury or death.

This vehicle has a higher centre of gravity. Vehicles with a higher centre of gravity such as utility vehicles handle differently than vehicles with a lower centre of gravity.

Utility vehicles are not designed for cornering at high speeds any more than low profile sports cars are designed to perform satisfactorily under off-road conditions.

In addition, utility vehicles have a significantly higher rollover rate than other types of vehicles.

In a rollover crash, an unbelted person is significantly more likely to die than a person wearing a seat belt.

Dry off brakes that have become wet by driving slowly, releasing the accelerator pedal and lightly applying the brakes several times until the brake performance returns to normal.

Driving with wet brakes is dangerous. Increased stopping distance or the vehicle pulling to one side when braking could result in a serious accident. Light braking will indicate whether the brakes have been affected.

CAUTION

- To protect the turbocharger system, perform idling immediately after high-speed driving or uphill driving before stopping the engine. Otherwise, it could cause a problem with the turbocharger system. After driving at high speed, idle for about 1 minute. After accelerating rapidly or ascending a steep slope, idle for about 2 minutes. Idling is not required when the i-stop is operating.
- Do not drive the vehicle on flooded roads as it could cause short circuiting of electrical/electronic parts, or engine damage or stalling from water absorption. If the vehicle has been immersed in water, consult an expert repairer (we recommend an Authorised Mazda Repairer).

Things to Be Observed When Parking or Stopping

WARNING

Never leave a child alone in the vehicle.

The temperature inside the cabin could become extremely hot which could be life-threatening.

An unattended child could operate equipment or accelerate the vehicle resulting in an accident.

CAUTION

- Do not leave any items in the vehicle that could cause a vehicle fire if they become hot.
The temperature inside the cabin could become extremely hot.
- Stop the vehicle in a place where there are no flammable objects.
- Do not leave the engine running in a poorly ventilated area, such as in a garage or in a snow-covered area.
If there is a malfunction in the exhaust pipe or exhaust noise, have the vehicle inspected.
There is a risk of carbon monoxide poisoning.
- Do not sleep in the vehicle with the engine running.
There is a risk that the vehicle may move unintentionally.

The Data Stored in The Vehicle

Data handling

Mazda and its contractors may obtain and use data recorded in EDRs and computers that record vehicle data for the purpose of vehicle malfunction diagnosis, research and development, and quality improvement.

Mazda will not disclose or provide any of the obtained data to a third party unless:

- An agreement from the vehicle owner (agreements from lessor and lessee for leased vehicle) is obtained
- Officially requested by the police or other law enforcement authorities
- For statistical processing by a research institution after processing the data so that identification of the owner or the vehicle is impossible

A computer that records vehicle data

A computer is equipped that records data related to the vehicle control, operation, and the driving environment.

This computer records information such as the following.

- Vehicle conditions such as engine speed and vehicle speed
- Driving operation conditions such as accelerator and brake pedals, and information related to the environmental circumstances while driving the vehicle
- Malfunction diagnosis information from on-vehicle computer
- Information related to controls of other on-vehicle computers

The recorded information differs depending on the vehicle grade and the equipment.

Personal information (name, sex, age, and collision location) is not recorded.

Instrument Cluster (Type A)

This product includes free/open sources. Information about the licensing and source code is available at the following URL.

<http://car.panasonic.jp/oss/j04ljmmb>

Libunibreak License

Licence

This library is released under an open-source licence, the zlib/libpng licence. Please check the file LICENCE for details.

Apart from using the algorithm, part of the code is derived from the data provided under

<URL:<http://www.unicode.org/Public/>>

And the Unicode Terms of Use may apply:

[URL:http://www.unicode.org/copyright.html](http://www.unicode.org/copyright.html)

LICENSE:

Copyright (C) 2008-2012 Wu Yongwei <wuyongwei at gmail dot com>

Copyright (C) 2012 Tom Hacothen <tom dot hacothen at samsung dot com>

This software is provided 'as-is', without any express or implied warranty. In no event will the author be held liable for any damages arising from the use of this software.

Permission is granted to anyone to use this software for any purpose, including commercial applications, and to alter it and redistribute it freely, subject to the following restrictions:

1. The origin of this software must not be misrepresented; you must not claim that you wrote the original software. If you use this software in a product, an acknowledgement in the product documentation would be appreciated but is not required.
2. Altered source versions must be plainly marked as such, and must not be misrepresented as being the original software.
3. This notice may not be removed or altered from any source distribution.

With respect to "Libunibreak Library", please be noted that this software includes the program altered from zlib.

Lua Disclaimer

Copyright © 1994-2016 Lua.org, PUC-Rio.

Permission is hereby granted, free of charge, to any person obtaining a copy of this software and associated documentation files (the "Software"), to deal in the Software without restriction, including without limitation the rights to use, copy, modify, merge, publish, distribute, sublicense, and/or sell copies of the Software, and to permit persons to whom the Software is furnished to do so, subject to the following conditions:

The above copyright notice and this permission notice shall be included in all copies or substantial portions of the Software. THE SOFTWARE IS PROVIDED "AS IS", WITHOUT WARRANTY OF ANY KIND, EXPRESS OR IMPLIED, INCLUDING BUT NOT LIMITED TO THE WARRANTIES OF MERCHANTABILITY, FITNESS FOR A PARTICULAR PURPOSE AND NONINFRINGEMENT. IN NO EVENT SHALL THE AUTHORS OR COPYRIGHT HOLDERS BE LIABLE FOR ANY CLAIM, DAMAGES OR OTHER LIABILITY, WHETHER IN AN ACTION OF CONTRACT, TORT OR OTHERWISE, ARISING FROM, OUT OF OR IN CONNECTION WITH THE SOFTWARE OR THE USE OR OTHER DEALINGS IN THE SOFTWARE.

Bidi.cpp Disclaimer

Credits:

Written by: Asmus Freytag

Command line interface by: Rick McGowan

Verification (v24): Doug Felt

Disclaimer and legal rights:

Copyright (C) 1999-2009, ASMUS, Inc. All Rights Reserved.

Distributed under the Terms of Use in

<http://www.unicode.org/copyright.html>.

THIS SOFTWARE IS PROVIDED "AS IS", WITHOUT WARRANTY OF ANY KIND, EXPRESS OR IMPLIED, INCLUDING BUT NOT LIMITED TO THE WARRANTIES OF MERCHANTABILITY, FITNESS FOR A PARTICULAR PURPOSE AND NONINFRINGEMENT OF THIRD PARTY RIGHTS. IN NO EVENT SHALL THE COPYRIGHT HOLDER OR HOLDERS INCLUDED IN THIS NOTICE BE LIABLE FOR ANY CLAIM, OR ANY SPECIAL INDIRECT OR CONSEQUENTIAL DAMAGES, OR ANY DAMAGES WHATSOEVER RESULTING FROM LOSS OF USE, DATA OR PROFITS, WHETHER IN AN ACTION OF CONTRACT, NEGLIGENCE OR OTHER TORTIOUS ACTION, ARISING OUT OF OR IN CONNECTION WITH THE USE OR PERFORMANCE OF THE SOFTWARE.

The file bid.rc is included in the software covered by the above.

Unicode.org Data Files Disclaimer

Copyright © 1991 - 2018 Unicode, Inc. All rights reserved.
Distributed under the Terms of Use in
<http://www.unicode.org/copyright.html>.

Permission is hereby granted, free of charge, to any person obtaining a copy of the Unipode data files and any associated documentation (the "Data Files") or Unicode software and any associated documentation (the "Software") to deal in the Data Files or Software without restriction, including without limitation the rights to use, copy, modify, merge, publish, distribute, and / or sell copies of the Data Files or Software, and to permit persons to whom the Data Files or Software are furnished to do so, provided that either

- (a) this copyright and permission notice appear with all copies of the Data Files or Software, or
- (b) this copyright and permission notice appear in associated Documentation.

THE DATA FILES AND SOFTWARE ARE PROVIDED "AS IS", WITHOUT WARRANTY OF ANY KIND, EXPRESS OR IMPLIED, INCLUDING BUT NOT LIMITED TO THE WARRANTIES OF MERCHANTABILITY, FITNESS FOR A PARTICULAR PURPOSE AND NONINFRINGEMENT OF THIRD PARTY RIGHTS.

IN NO EVENT SHALL THE COPYRIGHT HOLDER OR HOLDERS INCLUDED IN THIS NOTICE BE LIABLE FOR ANY CLAIM, OR ANY SPECIAL INDIRECT OR CONSEQUENTIAL DAMAGES, OR ANY DAMAGES WHATSOEVER RESULTING FROM LOSS OF USE, DATA OR PROFITS, WHETHER IN AN ACTION OF CONTRACT, NEGLIGENCE OR OTHER TORTIOUS ACTION, ARISING OUT OF OR IN CONNECTION WITH THE USE OR PERFORMANCE OF THE DATA FILES OR SOFTWARE.

Except as contained in this notice, the name of a copyright holder shall not be used in advertising or otherwise to promote the sale, use or other dealings in these Data Files or Software without prior written authorization of the copyright holder.

Unicode® Terms of Use

Unicode Copyright.

Copyright © 1991-2018 Unicode, Inc. All rights reserved.

Certain documents and files on this website contain a legend indicating that "Modification is permitted." Any person is hereby authorized, without fee, to modify such documents and files to create derivative works conforming to the Unicode® Standard, subject to Terms and Conditions herein.

Any person is hereby authorized, without fee, to view, use, reproduce, and distribute all documents and files, subject to the Terms and Conditions herein.

Further specifications of rights and restrictions pertaining to the use of the particular set of data files known as the "Unicode Character Database" can be found in the [License](#).

Each version of the Unicode Standard has further specifications of rights and restrictions of use. For the book editions (Unicode 5.0 and earlier), these are found on the back of the [title page](#). The online code charts carry specific restrictions. All other files, including online documentation of the core specification for Unicode 6.0 and later, are covered under these general Terms of Use.

No license is granted to "mirror" the Unicode website where a fee is charged for access to the "mirror" site.

Open Source Software Information

Modification is not permitted with respect to this document. All copies of this document must be verbatim.

Restricted Rights Legend. Any technical data or software which is licensed to the United States of America, its agencies and/or instrumentalities under this Agreement is commercial technical data or commercial computer software developed exclusively at private expense as defined in FAR 2.101, or DFARS 252.227-7014 (June 1995), as applicable. For technical data, use, duplication, or disclosure by the Government is subject to restrictions as set forth in DFARS 202.227-7015 Technical Data, Commercial and Items (Nov 1995) and this Agreement. For Software, in accordance with FAR 12-212 or DFARS 227-7202, as applicable, use, duplication or disclosure by the Government is subject to the restrictions set forth in this Agreement.

Warranties and Disclaimers.

This publication and/or website may include technical or typographical errors or other inaccuracies. Changes are periodically added to the information herein; these changes will be incorporated in new editions of the publication and/or website. Unicode may make improvements and/or changes in the product(s) and/or program(s) described in this publication and/or website at any time.

If this file has been purchased on magnetic or optical media from Unicode, Inc. the sole and exclusive remedy for any claim will be exchange of the defective media within ninety (90) days of original purchase.

EXCEPT AS PROVIDED IN SECTION C.2, THIS PUBLICATION AND/OR SOFTWARE IS PROVIDED "AS IS" WITHOUT WARRANTY OF ANY KIND EITHER EXPRESS, IMPLIED, OR STATUTORY, INCLUDING, BUT NOT LIMITED TO, ANY WARRANTIES OF MERCHANTABILITY, FITNESS FOR A PARTICULAR PURPOSE, OR NON-INFRINGEMENT. UNICODE AND ITS LICENSORS ASSUME NO RESPONSIBILITY FOR ERRORS OR OMISSIONS IN THIS PUBLICATION AND/OR SOFTWARE OR OTHER DOCUMENTS WHICH ARE REFERENCED BY OR LINKED TO THIS PUBLICATION OR THE UNICODE WEBSITE.

Waiver of Damages. In no event shall Unicode or its licensors be liable for any special, incidental, indirect or consequential damages of any kind, or any damages whatsoever, whether or not Unicode was advised of the possibility of the damage, including, without limitation, those resulting from the following: loss of use, data or profits, in connection with the use, modification or distribution of this information or its derivatives.

Trademarks & Logos.

The Unicode Word Mark and the Unicode Logo are trademarks of Unicode, Inc. "The Unicode Consortium" and "Unicode, Inc." are trade names of Unicode, Inc. Use of the information and materials found on this website indicates your acknowledgement of Unicode, Inc.'s exclusive worldwide rights in the Unicode Word Mark, the Unicode Logo, and the Unicode trade names.

The Unicode Consortium Name and Trademark Usage Policy ("Trademark Policy") are incorporated herein by reference and you agree to abide by the provisions of the Trademark Policy, which may be changed from time to time in the sole discretion of Unicode, Inc.

All third party trademarks referenced herein are the property of their respective owners.

Miscellaneous.

Jurisdiction and Venue. This server is operated from a location in the State of California, United States of America. Unicode makes no representation that the materials are appropriate for use in other locations. If you access this server from other locations, you are responsible for compliance with local laws. This Agreement, all use of this site and any claims and damages resulting from use of this site

are governed solely by the laws of the State of California without regard to any principles which would apply the laws of a different jurisdiction. The user agrees that any disputes regarding this site shall be resolved solely in the courts located in Santa Clara County, California. The user agrees said courts have personal jurisdiction and agree to waive any right to transfer the dispute to any other forum. Modification by Unicode. Unicode shall have the right to modify this Agreement at any time by posting it to this site. The user may not assign any part of this Agreement without Unicode's prior written consent.

Taxes. The user agrees to pay any taxes arising from access to this website or use of the information herein, except for those based on Unicode's net income.

Severability. If any provision of this Agreement is declared invalid or unenforceable, the remaining provisions of this Agreement shall remain in effect.

Entire Agreement. This Agreement constitutes the entire agreement between the parties.

EXHIBIT 1

UNICODE, INC. LICENSE AGREEMENT - DATA FILES AND SOFTWARE

Unicode Data Files include all data files under the directories <http://www.unicode.org/Public/>, <http://www.unicode.org/reports/>, <http://www.unicode.org/cldr/data/>, <http://source.icu-project.org/repos/icu/>, and <http://www.unicode.org/utility/trac/browser/>.

Unicode Data Files do not include PDF online code charts under the directory <http://www.unicode.org/Public/>.

Software includes any source code published in the Unicode Standard or under the directories

<http://www.unicode.org/Public/>, <http://www.unicode.org/reports/>, <http://www.unicode.org/cldr/data/>, <http://source.icu-project.org/repos/icu/>, and <http://www.unicode.org/utility/trac/browser/>.

Open Source Software Information

NOTICE TO USER: Carefully read the following legal agreement.
BY DOWNLOADING, INSTALLING, COPYING OR OTHERWISE USING UNICODE INC.'S
DATA FILES ("DATA FILES"), AND/OR SOFTWARE ("SOFTWARE"),
YOU UNEQUIVOCALLY ACCEPT, AND AGREE TO BE BOUND BY, ALL OF THE
TERMS AND CONDITIONS OF THIS AGREEMENT.

IF YOU DO NOT AGREE, DO NOT DOWNLOAD, INSTALL, COPY, DISTRIBUTE OR USE
THE DATA FILES OR SOFTWARE.

COPYRIGHT AND PERMISSION NOTICE

Copyright © 1991-2018 Unicode, Inc. All rights reserved.
Distributed under the Terms of Use in
<http://www.unicode.org/copyright.html>.

Permission is hereby granted, free of charge, to any person obtaining
a copy of the Unicode data files and any associated documentation (the
"Data Files") or Unicode software and any associated documentation
(the "Software") to deal in the Data Files or Software without
restriction, including without limitation the rights to use, copy,
modify, merge, publish, distribute, and/or sell copies of the Data
Files or Software, and to permit persons to whom the Data Files or
Software are furnished to do so, provided that either (a) this
copyright and permission notice appear with all copies of the Data
Files or Software, or (b) this copyright and permission notice appear
in associated Documentation.

THE DATA FILES AND SOFTWARE ARE PROVIDED "AS IS", WITHOUT WARRANTY OF
ANY KIND, EXPRESS OR IMPLIED, INCLUDING BUT NOT LIMITED TO THE
WARRANTIES OF MERCHANTABILITY, FITNESS FOR A PARTICULAR PURPOSE AND
NONINFRINGEMENT OF THIRD PARTY RIGHTS.

IN NO EVENT SHALL THE COPYRIGHT HOLDER OR HOLDERS INCLUDED IN THIS
NOTICE BE LIABLE FOR ANY CLAIM, OR ANY SPECIAL INDIRECT OR
CONSEQUENTIAL
DAMAGES, OR ANY DAMAGES WHATSOEVER RESULTING FROM LOSS OF USE,
DATA OR PROFITS, WHETHER IN AN ACTION OF CONTRACT, NEGLIGENCE OR OTHER
TORTIOUS ACTION, ARISING OUT OF OR IN CONNECTION WITH THE USE OR
PERFORMANCE OF THE DATA FILES OR SOFTWARE.

Except as contained in this notice, the name of a copyright holder
shall not be used in advertising or otherwise to promote the sale, use
or other dealings in these Data Files or Software without prior
written authorization of the copyright holder.

Khronos

```
** Copyright (c) 2017 The Khronos Group Inc.
**
** Licensed under the Apache License, Version 2.0 (the "License");
** you may not use this file except in compliance with the License.
** You may obtain a copy of the License at
**
**   http://www.apache.org/licenses/LICENSE-2.0
**
** Unless required by applicable law or agreed to in writing, software
** distributed under the License is distributed on an "AS IS" BASIS,
** WITHOUT WARRANTIES OR CONDITIONS OF ANY KIND, either express or implied.
** See the License for the specific language governing permissions and
** limitations under the License.
** Copyright (c) 2007-2016 The Khronos Group Inc.
** Copyright (c) 2008-2009 The Khronos Group Inc.
** Copyright (c) 2013-2016 The Khronos Group Inc.
** Copyright (c) 2013-2017 The Khronos Group Inc.
**
** Permission is hereby granted, free of charge, to any person obtaining a
** copy of this software and/or associated documentation files (the
** "Materials"), to deal in the Materials without restriction, including
** without limitation the rights to use, copy, modify, merge, publish,
** distribute, sublicense, and/or sell copies of the Materials, and to
** permit persons to whom the Materials are furnished to do so, subject to
** the following conditions:
**
** The above copyright notice and this permission notice shall be included
** in all copies or substantial portions of the Materials.
**
** THE MATERIALS ARE PROVIDED "AS IS", WITHOUT WARRANTY OF ANY KIND,
** EXPRESS OR IMPLIED, INCLUDING BUT NOT LIMITED TO THE WARRANTIES OF
** MERCHANTABILITY, FITNESS FOR A PARTICULAR PURPOSE AND NONINFRINGEMENT.
** IN NO EVENT SHALL THE AUTHORS OR COPYRIGHT HOLDERS BE LIABLE FOR ANY
** CLAIM, DAMAGES OR OTHER LIABILITY, WHETHER IN AN ACTION OF CONTRACT,
** TORT OR OTHERWISE, ARISING FROM, OUT OF OR IN CONNECTION WITH THE
** MATERIALS OR THE USE OR OTHER DEALINGS IN THE MATERIALS.
```

Open Source Software Information

@Copyright Copyright (c) Imagination Technologies Ltd. All Rights Reserved
@License MIT

The contents of this file are subject to the MIT license as set out below.

Permission is hereby granted, free of charge, to any person obtaining a copy of this software and associated documentation files (the "Software"), to deal in the Software without restriction, including without limitation the rights to use, copy, modify, merge, publish, distribute, sublicense, and/or sell copies of the Software, and to permit persons to whom the Software is furnished to do so, subject to the following conditions:

The above copyright notice and this permission notice shall be included in all copies or substantial portions of the Software.

THE SOFTWARE IS PROVIDED "AS IS", WITHOUT WARRANTY OF ANY KIND, EXPRESS OR IMPLIED, INCLUDING BUT NOT LIMITED TO THE WARRANTIES OF MERCHANTABILITY, FITNESS FOR A PARTICULAR PURPOSE AND NONINFRINGEMENT. IN NO EVENT SHALL THE AUTHORS OR COPYRIGHT HOLDERS BE LIABLE FOR ANY CLAIM, DAMAGES OR OTHER LIABILITY, WHETHER IN AN ACTION OF CONTRACT, TORT OR OTHERWISE, ARISING FROM, OUT OF OR IN CONNECTION WITH THE SOFTWARE OR THE USE OR OTHER DEALINGS IN THE SOFTWARE.

Apache License
Version 2.0, January 2004
<http://www.apache.org/licenses/>

TERMS AND CONDITIONS FOR USE, REPRODUCTION, AND DISTRIBUTION

1. Definitions.

"License" shall mean the terms and conditions for use, reproduction, and distribution as defined by Sections 1 through 9 of this document.

"Licensor" shall mean the copyright owner or entity authorized by the copyright owner that is granting the License.

"Legal Entity" shall mean the union of the acting entity and all other entities that control, are controlled by, or are under common control with that entity. For the purposes of this definition, "control" means (i) the power, direct or indirect, to cause the direction or management of such entity, whether by contract or otherwise, or (ii) ownership of fifty percent (50%) or more of the outstanding shares, or (iii) beneficial ownership of such entity.

"You" (or "Your") shall mean an individual or Legal Entity exercising permissions granted by this License.

"Source" form shall mean the preferred form for making modifications, including but not limited to software source code, documentation source, and configuration files.

"Object" form shall mean any form resulting from mechanical transformation or translation of a Source form, including but not limited to compiled object code, generated documentation, and conversions to other media types.

"Work" shall mean the work of authorship, whether in Source or Object form, made available under the License, as indicated by a copyright notice that is included in or attached to the work (an example is provided in the Appendix below).

"Derivative Works" shall mean any work, whether in Source or Object form, that is based on (or derived from) the Work and for which the editorial revisions, annotations, elaborations, or other modifications represent, as a whole, an original work of authorship. For the purposes of this License, Derivative Works shall not include works that remain separable from, or merely link (or bind by name) to the interfaces of, the Work and Derivative Works thereof.

"Contribution" shall mean any work of authorship, including the original version of the Work and any modifications or additions to that Work or Derivative Works thereof, that is intentionally submitted to Licensor for inclusion in the Work by the copyright owner or by an individual or Legal Entity authorized to submit on behalf of the copyright owner. For the purposes of this definition, "submitted" means any form of electronic, verbal, or written communication sent to the Licensor or its representatives, including but not limited to communication on electronic mailing lists, source code control systems, and issue tracking systems that are managed by, or on behalf of, the Licensor for the purpose of discussing and improving the Work, but excluding communication that is conspicuously marked or otherwise designated in writing by the copyright owner as "Not a Contribution."

"Contributor" shall mean Licensor and any individual or Legal Entity on behalf of whom a Contribution has been received by Licensor and subsequently incorporated within the Work.

2. Grant of Copyright License. Subject to the terms and conditions of this License, each Contributor hereby grants to You a perpetual, worldwide, non-exclusive, no-charge, royalty-free, irrevocable copyright license to reproduce, prepare Derivative Works of, publicly display, publicly perform, sublicense, and distribute the Work and such Derivative Works in Source or Object form.
3. Grant of Patent License. Subject to the terms and conditions of this License, each Contributor hereby grants to You a perpetual, worldwide, non-exclusive, no-charge, royalty-free, irrevocable (except as stated in this section) patent license to make, have made, use, offer to sell, sell, import, and otherwise transfer the Work, where such license applies only to those patent claims licensable by such Contributor that are necessarily infringed by their Contribution(s) alone or by combination of their Contribution(s) with the Work to which such Contribution(s) was submitted. If You institute patent litigation against any entity (including a cross-claim or counterclaim in a lawsuit) alleging that the Work or a Contribution incorporated within the Work constitutes direct or contributory patent infringement, then any patent licenses granted to You under this License for that Work shall terminate as of the date such litigation is filed.

4. Redistribution. You may reproduce and distribute copies of the Work or Derivative Works thereof in any medium, with or without modifications, and in Source or Object form, provided that You meet the following conditions:
- (a) You must give any other recipients of the Work or Derivative Works a copy of this License; and
 - (b) You must cause any modified files to carry prominent notices stating that You changed the files; and
 - (c) You must retain, in the Source form of any Derivative Works that You distribute, all copyright, patent, trademark, and attribution notices from the Source form of the Work, excluding those notices that do not pertain to any part of the Derivative Works; and
 - (d) If the Work includes a "NOTICE" text file as part of its distribution, then any Derivative Works that You distribute must include a readable copy of the attribution notices contained within such NOTICE file, excluding those notices that do not pertain to any part of the Derivative Works, in at least one of the following places: within a NOTICE text file distributed as part of the Derivative Works; within the Source form or documentation, if provided along with the Derivative Works; or, within a display generated by the Derivative Works, if and wherever such third-party notices normally appear. The contents of the NOTICE file are for informational purposes only and do not modify the License. You may add Your own attribution notices within Derivative Works that You distribute, alongside or as an addendum to the NOTICE text from the Work, provided that such additional attribution notices cannot be construed as modifying the License.

You may add Your own copyright statement to Your modifications and may provide additional or different license terms and conditions for use, reproduction, or distribution of Your modifications, or for any such Derivative Works as a whole, provided Your use, reproduction, and distribution of the Work otherwise complies with the conditions stated in this License.

Open Source Software Information

5. **Submission of Contributions.** Unless You explicitly state otherwise, any Contribution intentionally submitted for inclusion in the Work by You to the Licensor shall be under the terms and conditions of this License, without any additional terms or conditions.
Notwithstanding the above, nothing herein shall supersede or modify the terms of any separate license agreement you may have executed with Licensor regarding such Contributions.
6. **Trademarks.** This License does not grant permission to use the trade names, trademarks, service marks, or product names of the Licensor, except as required for reasonable and customary use in describing the origin of the Work and reproducing the content of the NOTICE file.
7. **Disclaimer of Warranty.** Unless required by applicable law or agreed to in writing, Licensor provides the Work (and each Contributor provides its Contributions) on an "AS IS" BASIS, WITHOUT WARRANTIES OR CONDITIONS OF ANY KIND, either express or implied, including, without limitation, any warranties or conditions of TITLE, NON-INFRINGEMENT, MERCHANTABILITY, or FITNESS FOR A PARTICULAR PURPOSE. You are solely responsible for determining the appropriateness of using or redistributing the Work and assume any risks associated with Your exercise of permissions under this License.
8. **Limitation of Liability.** In no event and under no legal theory, whether in tort (including negligence), contract, or otherwise, unless required by applicable law (such as deliberate and grossly negligent acts) or agreed to in writing, shall any Contributor be liable to You for damages, including any direct, indirect, special, incidental, or consequential damages of any character arising as a result of this License or out of the use or inability to use the Work (including but not limited to damages for loss of goodwill, work stoppage, computer failure or malfunction, or any and all other commercial damages or losses), even if such Contributor has been advised of the possibility of such damages.
9. **Accepting Warranty or Additional Liability.** While redistributing the Work or Derivative Works thereof, You may choose to offer, and charge a fee for, acceptance of support, warranty, indemnity, or other liability obligations and/or rights consistent with this License. However, in accepting such obligations, You may act only on Your own behalf and on Your sole responsibility, not on behalf of any other Contributor, and only if You agree to indemnify, defend, and hold each Contributor harmless for any liability incurred by, or claims asserted against, such Contributor by reason of your accepting any such warranty or additional liability.

END OF TERMS AND CONDITIONS

APPENDIX: How to apply the Apache License to your work.

To apply the Apache License to your work, attach the following boilerplate notice, with the fields enclosed by brackets “[]” replaced with your own identifying information. (Don't include the brackets!) The text should be enclosed in the appropriate comment syntax for the file format. We also recommend that a file or class name and description of purpose be included on the same “printed page” as the copyright notice for easier identification within third-party archives.

Copyright [yyyy] [name of copyright owner]

Licensed under the Apache License, Version 2.0 (the “License”);
you may not use this file except in compliance with the License.
You may obtain a copy of the License at

<http://www.apache.org/licenses/LICENSE-2.0>

Unless required by applicable law or agreed to in writing, software distributed under the License is distributed on an “AS IS” BASIS, WITHOUT WARRANTIES OR CONDITIONS OF ANY KIND, either express or implied. See the License for the specific language governing permissions and limitations under the License.

Active Driving Display

This product includes free/open sources. Information about the licensing and source code is available at the following URL.

https://www.nippon-seiki.co.jp/business_ic_meter/

Driver Monitoring Camera

Free/Open Source Software Information

This product includes free/open source software. Information about licenses and source codes can be found at the following website.

http://www.embedded-carmultimedia.jp/RTOS/License/oss/DMS_0201/

Cruising & Traffic Support (CTS)

Free/Open Source Software Information

This product includes software created from free/open sources. Information about free/open source licenses can be found at the following website.
<http://acado.github.io/licensing>

MEMO

3

Equipment to Protect Occupants/ Pedestrians

SRS Air Bags.....	3-2
SRS Air Bags.....	3-2
Warnings and Cautions for Using the SRS Air Bags.....	3-4
Deployment of SRS air bags.....	3-8
Front Passenger Occupant Classification System*.....	3-13
Warnings and Cautions for Using the Front Passenger Occupant Classification System*.....	3-13
How to Use the Front Passenger Occupant Classification System*.....	3-15
Seat Belts.....	3-17
Seat Belts.....	3-17
Warnings and Cautions for Using the Seat Belts.....	3-18
How to Use the Seat Belts....	3-21
Front Seats.....	3-23
Warnings and Cautions for Using the Front Seats.....	3-23
How to Use the Front Seats.....	3-25
Driving Position Memory*.....	3-27
Warnings and Cautions for Using the Driving Position Memory.....	3-28
How to Use the Driving Position Memory.....	3-28
Rear Seats.....	3-30
Warnings and Cautions for Using the Rear Seats.....	3-30
How to Use the Rear Seats.....	3-32
Warnings and Cautions for Using the Armrests.....	3-34
How to Use the Armrests.....	3-35
Head Restraints.....	3-36
Head Restraints.....	3-36
Warnings and Cautions for Using the Head Restraints.....	3-36
How to Use the Head Restraints.....	3-37
Steering Wheel.....	3-39
Warnings and Cautions for Using the Steering Wheel.....	3-39
How to Use the Steering Wheel.....	3-39
Child-restraint Systems.....	3-40
Child-restraint Systems.....	3-40
Warnings and Cautions For Child- restraint Systems.....	3-40
Types of Child-restraint Systems.....	3-46
Child-restraint System Installation.....	3-49
Child-Restraint System Suitability for Various Seat Positions Table.....	3-53
How to Use the ISOFIX Anchor and Anchor Bracket.....	3-59

SRS Air Bags

If the vehicle receives a strong impact from the front or side of the vehicle when the vehicle power is switched ON, the air bags inflate instantaneously and lessen the impact on the head or chest of the driver or passenger.

The SRS air bag system protects occupants together with the seat belts and they are not a substitute for the seat belts.

There are 5 types of air bags.

Driver's front air bag

The driver's front air bag is stored in the centre of the steering wheel.

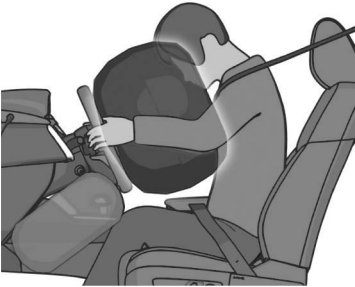

Front passenger's front air bag

The front passenger's front air bag is stored in the instrument panel.



Driver's knee air bag

The knee air bag is stored under the instrument panel.



Side air bags

There are 3 types of side air bags including the side air bags for the driver and front passenger (inboard/outboard) and rear passengers (outboard).

Front seat side air bags

The front seat side air bags are installed in the inboard side of the driver's seatback and in the outboard sides of the driver and front passenger's seatbacks.

(Inboard)*



(Outboard)



Rear seat side air bags*

The rear seat side air bags are installed in the rear pillars. The rear seat side air bags on the side where the vehicle is hit deploys regardless of whether or not an occupant is seated.

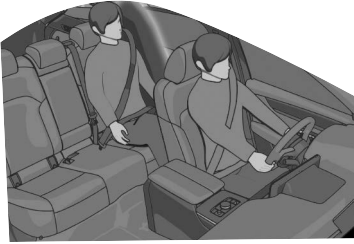

Curtain air bags

The curtain air bags are stored in the front pillars, side edges of the roof, and the rear pillars. The curtain air bag on the side where the vehicle is hit deploys regardless of the whether or not an occupant is seated.

In a side impact:

Greater than moderate impact to one side of the vehicle will cause the curtain air bag on that side only to inflate.

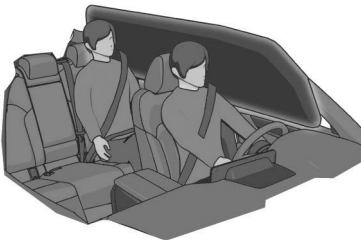

Vehicles with side air bag (inboard)

Both side curtain air bags will deploy regardless of the side the vehicle receives the impact on.

In a roll-over:*

In response to a vehicle roll-over, both curtain air bags inflate.

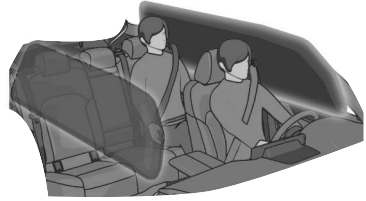

Constant Monitoring

The following components of the air bag systems are monitored by a diagnostic system:

- Front air bag sensors
- Crash sensors, and diagnostic module (SAS unit)
- Side crash sensors
- Air bag modules
- Seat belt pretensioners
- Air bag/Seat belt pretensioner system warning light
- Related wiring

(With Front Passenger Occupant Classification System)

- Front passenger occupant classification sensor
- Front passenger occupant classification module
- Front passenger air bag deactivation indicator light
- Front passenger seat belt buckle switch

The diagnostic module continuously monitors the system's readiness. This begins when the vehicle power is switched ON and continues while the vehicle is being driven.

Warnings and Cautions for Using the SRS Air Bags

WARNING

Seat belts must be worn in air bag equipped vehicles.

Depending only on the air bags for protection during an accident is dangerous. Alone, air bags may not prevent serious injuries. The appropriate air bags can be expected to inflate only in the first accident, such as frontal, near frontal or side collisions or roll-over accidents that are at least moderate. Vehicle occupants should always wear seat belts.

Children should not ride in the front passenger seat.

Placing a child, 12 years or under, in the front seat is dangerous. The child could be hit by a deploying air bag and be seriously injured or even killed. A sleeping child is more likely to lean against the door and be hit by the side air bag in moderate collision to the front-passenger side of the vehicle. Whenever possible, always secure a child 12 years and under on the rear seats with an appropriate child-restraint system for the child's age and size.

Extreme Hazard! Never use a rear-facing child-restraint system on the front passenger seat with an air bag that could deploy.

NEVER use a rearward facing child restraint on a seat protected by an ACTIVE AIRBAG in front of it, DEATH or SERIOUS INJURY to the CHILD can occur.

Even in a moderate collision, the child-restraint system can be hit by a deploying air bag and moved violently backward resulting in serious injury or death to the child.



Do not sit too close to the driver and front passenger air bags.

Sitting too close to the driver and front passenger air bag modules or placing hands or feet on them is extremely dangerous. The driver and front passenger air bags inflate with great force and speed. Serious injuries could occur if someone is too close. The driver should always hold onto only the rim of the steering wheel. The front seat passenger should keep both feet on the floor. Front seat occupants should adjust their seats as far back as possible and always sit upright against the seatbacks with seat belts worn properly.

Sit in the centre of the seat and wear seat belts properly.

Sitting too close to the side air bag modules or placing hands on them, or hanging out the windows is extremely dangerous. The side and curtain air bags inflate with great force and speed directly expanding along the door on the side the car is hit. Serious injury could occur if someone is sitting too close to the door or leaning against a window, or if rear seat occupants grab the sides of the front seatbacks. Give the side and curtain air bags room to work by sitting in the centre of the seat while the vehicle is moving with seat belts worn properly.

Do not attach objects on or around the area where air bags deploy.

Attaching objects to the air bags or placing something in the area where the air bags deploy is dangerous. In an accident, an object could interfere with air bag inflation and injure the occupants. Furthermore, the bag could be damaged causing gases to release. Always keep the deployment area of the air bag modules free of any obstructions.

For example, you should not do any of the following as it may interfere with air bag deployment.

- Do not put a covering on or lean anything against areas such as the instrument panel and lower portion of the instrument panel that blocks the passenger front air bag and knee air bags.
- Do not use seat covers on the front seats and rear seats equipped with in-seat side air bags.
- Do not hang any backpacks, bags or pouches that cover the sides of the seats that block the side air bags.

- Do not place any objects on the assist grips. Only hang clothes directly on the coat hooks.

Do not touch the components of the supplementary restraint system after the air bags have inflated.

Touching the components of the supplementary restraint system after the air bags have inflated is dangerous. Immediately after inflation, they are very hot. You could get burned.

Never install any front-end equipment to your vehicle.

Installation of front-end equipment, such as frontal protection bar (kangaroo bar, bull bar, push bar, or other similar devices), snowplough, or winches, is dangerous. The air bag crash sensor system could be affected. This could cause air bags to inflate unexpectedly, or it could prevent the air bags from inflating during an accident. Front occupants could be seriously injured.

Do not modify the suspension.

Modifying the vehicle suspension is dangerous. If the vehicle's height or the suspension is modified, the vehicle will be unable to accurately detect a collision or roll-over accident resulting in incorrect or unexpected air bag deployment and the possibility of serious injuries.

SRS Air Bags

To prevent false detection by the air bag sensor system, heed the following.

- Do not use tyres or wheels other than those specified for your Mazda. Use of any tyre or wheel other than those specified for your Mazda (page 10-91) is dangerous. Use of such wheels will prevent the vehicle's accident detection system from accurately detecting a collision or roll-over accident resulting in incorrect or unexpected air bag deployment and the possibility of serious injuries.

Do not modify a front door or leave any damage unrepaired. Always have an expert repairer (we recommend an Authorised Mazda Repairer) inspect a damaged front door.

Modifying a front door or leaving any damage unrepaired is dangerous. Each front door has a side crash sensor as a component of the supplementary restraint system. If holes are drilled in a front door, a door speaker is left removed, or a damaged door is left unrepaired, the sensor could be adversely affected causing it to not detect the pressure of an impact correctly during a side collision. If a sensor does not detect a side impact correctly, the side and curtain air bags and the front seat belt pretensioner may not operate normally which could result in serious injury to occupants.

Do not modify the supplementary restraint system.

Modifying the components or wiring of the supplementary restraint system is dangerous. You could accidentally activate it or make it inoperable. Do not make any modifications to the supplementary restraint system. This includes installing trim, badges, or anything else over the air bag modules. It also includes installing extra electrical equipment on or near system components or wiring. An expert repairer (we recommend an Authorised Mazda Repairer) can provide the special care needed in the removal and installation of front seats. It is important to protect the air bag wiring and connections to assure that the bags do not accidentally deploy and the seats retain an undamaged air bag connection.

Do not place luggage or other objects under the front seats.

Placing luggage or other objects under the front seats is dangerous. The components essential to the supplementary restraint system could be damaged, and in the event of a side collision, the appropriate air bags may not deploy, which could result in death or serious injury. To prevent damage to the components essential to the supplementary restraint system, do not place luggage or other objects under the front seats.

Do not operate a vehicle with damaged air bag/seat belt pretensioner system components.

Expend or damaged air bag/seat belt pretensioner system components must be replaced after any collision which caused them to deploy or damage them. Only a trained expert repairer (we recommend an Authorised Mazda Repairer) can fully evaluate these systems to see that they will work in any subsequent accident. Driving with an expended or damaged air bag or pretensioner unit will not afford you the necessary protection in the event of any subsequent accident which could result in serious injury or death.

Do not remove interior air bag parts.

Removing any components such as the front seats, front instrument panel, the steering wheel or parts on the front and rear window pillars and along the roof edge, containing air bag parts or sensors is dangerous. These parts contain essential air bag components. The air bag could accidentally activate and cause serious injuries. Always have an expert repairer (we recommend an Authorised Mazda Repairer) remove these parts.

Properly dispose of the air bag system.

Improper disposal of an air bag or a vehicle with live air bags in it can be extremely dangerous. Unless all safety procedures are followed, injury could result. Have an expert repairer (we recommend an Authorised Mazda Repairer) safely dispose of the air bag system or scrap an air bag equipped vehicle.

SRS Air Bags

Deployment of SRS air bags

Deployment of SRS air bags

The driver's and front passenger's front air bags, and the driver's knee air bag deploy when a strong impact is applied to the vehicle in a frontal collision, and the side and curtain air bags deploy in side collisions.

The air bags do not always deploy even if the vehicle receives an impact.

Conditions in which air bags may not deploy

The air bags may not deploy under the following conditions depending on the level of the impact.

Driver's and front passenger's air bags, driver's knee air bag

(Impacts involving trees or poles)

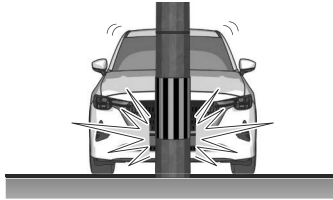

(Rear-ending or running under a truck's tail gate)

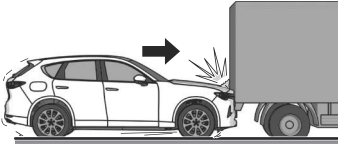

(Frontal offset impact to the vehicle)

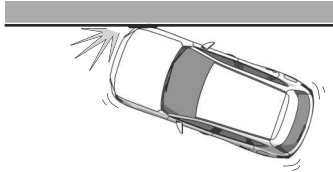

Side and curtain air bags

(Frontal offset impact to the vehicle)

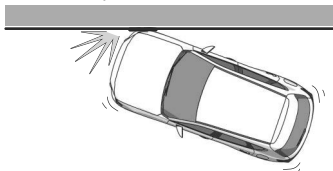

(Pitch end over end)

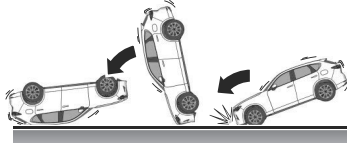

(Side impacts involving trees or poles from the vehicle side (around driver or front passenger))

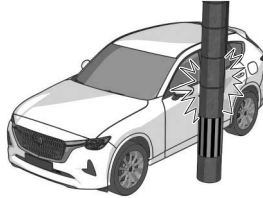

(Side impacts with two-wheeled vehicles)

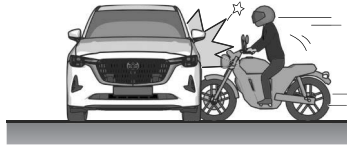

Conditions in which air bags do not deploy

The air bags do not deploy under the following conditions.

Driver's and front passenger's air bags, driver's knee air bag

(Rear impact)



(Roll-over)

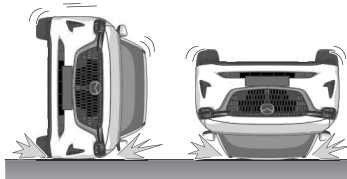

(Pitch end over end)

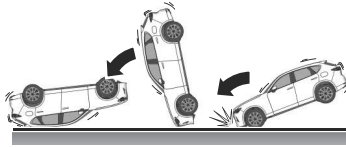

(Lateral direction side impact)

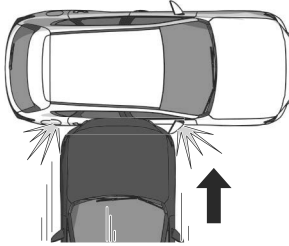

Side and curtain air bags

(Rear impact)



(Frontal impact)

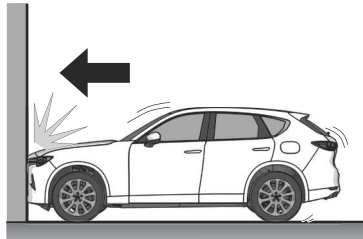

NOTE

- When an air bag deploys, a loud inflation noise can be heard and some smoke will be released. Neither is likely to cause injury, however, the texture of the air bags may cause light skin injuries on body parts not covered with clothing through friction.
- Should you sell your Mazda, we urge you to tell the new owner of its air bag systems and that familiarization with all instructions about them, from the Owner's Manual, is important.
- This highly-visible label warns against the use of a rear-facing child-restraint system on the front passenger seat.

(Europe and other countries (Except Taiwan))



(Taiwan Only)



依規定前排座椅禁止乘載嬰兒、幼童及兒童。

(Taiwan, except front passenger seat, if equipped with the following label)

The highly-visible labels warn against the use of a rear-facing child-restraint system on the seat protected by an air bag.



Air bag structural view

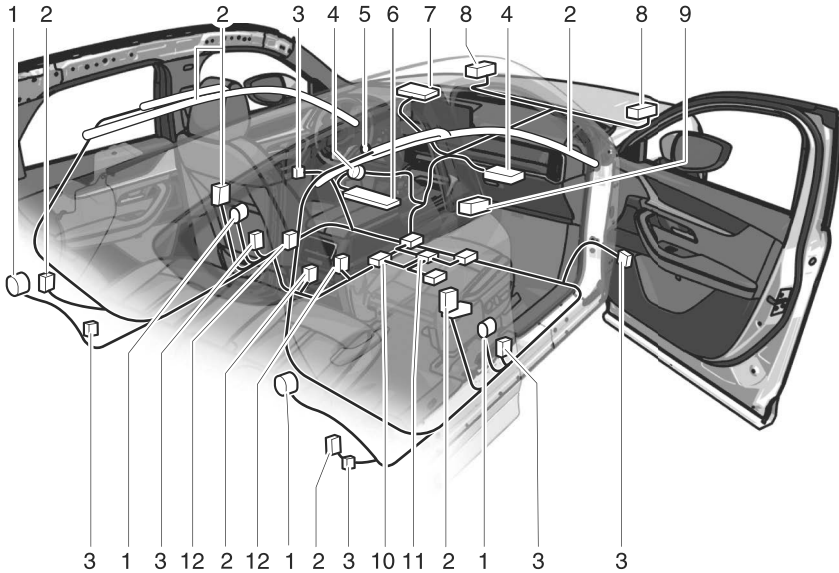

1. Seat belt pretensioners
2. Side and curtain inflators and air bags*
3. Side crash sensors*
4. Driver/Front passenger inflators and air bags
5. Air bag/seat belt pretensioner system warning indication/warning light
6. Driver knee inflator and air bag
7. Front passenger air bag deactivation indicator light
8. Front air bag sensors
9. Roll-over sensor*, crash sensors, and diagnostic module (SAS unit)
10. Front passenger seat weight sensors*
11. Front passenger seat weight sensor control module*
12. Front passenger seat belt buckle switches*

Front Passenger Occupant Classification System*

The Front Passenger Occupant Classification System reduces the possibility of injury due to the deployment of the front passenger air bags by determining whether or not the front passenger's air bags can be deployed based on the front passenger's seat sensor.

Warnings and Cautions for Using the Front Passenger Occupant Classification System*

WARNING

Do not decrease the total seated weight on the front passenger seat.

When an adult or large child sits on the front passenger seat, decreasing the total seated weight on the front passenger seat required for air bag deployment is dangerous. The front passenger seat weight sensors will detect the reduced total seated weight condition and the front passenger front and side air bags, and the seat belt pretensioner system will not deploy during an accident. The front passenger will not have the supplementary protection of the air bag, which could result in serious injury. Decreasing the total seated weight on the front passenger seat could result in an air bag not deploying under the following conditions, for example.

- A front passenger is seated as shown in the following figure.



- A rear passenger pushes up on the front passenger seat with their feet.

- Luggage or other items placed under the front passenger seat or between the front passenger seat and driver seat that push up the front passenger seat bottom.
- Any accessories which might decrease the total seated weight on the front passenger seat are attached to the front passenger seat. The front passenger front and side air bags, and the seat belt pretensioner system will deactivate if the front passenger air bag deactivation indicator light illuminates.

Do not increase the total seated weight on the front passenger seat.

When an infant or small child sits on the front passenger seat, increasing the total seated weight on the front passenger seat is dangerous. The front passenger seat weight sensors will detect the increased total seated weight, which could result in the unexpected deployment of the front passenger front and side air bags, and seat belt pretensioner system in an accident and may cause serious injury. Increasing the total seated weight on the front passenger seat could result in the front passenger front and side air bags, and seat belt pretensioner system deployment in an accident under the following conditions, for example.

- Luggage or other items are placed on the seat with the child in the child-restraint system.
- A rear passenger or luggage push or pull down on the front passenger seatback.
- A rear passenger steps on the front passenger seat rails with their feet.

- Luggage or other items are placed on the seatback or hung on the head restraint.
- Heavy items are placed in the seatback map pocket.
- The seat is washed.
- Liquids are spilled on the seat.
- The front passenger seat is moved backward, pushing into luggage or other items placed behind it.
- The front passenger seatback contacts the rear seat.
- Luggage or other items are placed between the front passenger seat and driver seat.
- Any accessories which might increase the total seated weight on the front passenger seat are attached to the front passenger seat.

⚠ CAUTION

- To assure proper deployment of the front air bag and to prevent damage to the sensors in the front seat bottoms.
 - Do not place sharp objects on the front seat bottoms or leave heavy luggage on them.
 - Do not spill any liquids on the front seats or under the front seats.
- To allow the sensors to function properly, always perform the following.
 - Adjust the front seats as far back as possible and always sit upright against the seatbacks with seat belts worn properly.
 - If you place your child on the front passenger seat, secure the child-restraint system properly and slide the front passenger seat as far back as possible (page 3-25).

How to Use the Front Passenger Occupant Classification System*

The front passenger air bag deactivation indicator light indicates whether or not the front passenger's air bag can be deployed. Switch the vehicle power ON. The indicator light turns on and a system check is performed.

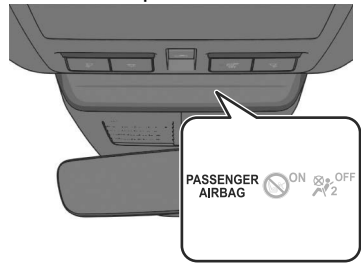

After the system check is performed, the indicator light turns off. The indicator light turns on or off under the following conditions.

Status	Front passenger front and side air bags, and seat belt pretensioner Operation Condition	Front Passenger Air Bag Deactivation Indicator Light
OFF position	Deactivate	OFF
ON position	Ready	ON Turns off after a short period of time.

SRS Air Bags

NOTE

- The system requires a certain period of time to alternate between turning the front passenger front and side air bags, and seat belt pretensioner system on or off.
 - The front passenger air bag deactivation indicator light may illuminate repeatedly if luggage or other items are put on the front passenger seat, or if the temperature of the vehicle's interior changes suddenly.
 - The front passenger air bag deactivation indicator light may illuminate for a certain period of time if the total seated weight on the front passenger seat changes.
 - The air bag/front seat belt pretensioner system warning light might illuminate if the front passenger seat receives a severe impact.
 - If the front passenger air bag deactivation indicator light does not illuminate after installing a child-restraint system on the front passenger seat, first, re-install your child-restraint system according to the procedure in this owner's manual. Then, if the front passenger air bag deactivation indicator light still does not illuminate, install the child-restraint system on the rear seat and consult an expert repairer (we recommend an Authorised Mazda Repairer) as soon as possible.
- If the front passenger air bag deactivation indicator light illuminates when an adult is seated in the front passenger seat, have the passenger re-adjust their posture by sitting with their feet on the floor, and then re-fastening the seat belt. If the front passenger air bag deactivation indicator light still illuminates, move the passenger to the rear seat. If sitting in the rear seat is not possible, slide the front passenger seat as far back as possible. Consult an expert repairer (we recommend an Authorised Mazda Repairer) as soon as possible.

Seat Belts

Seat belts help to decrease the possibility of severe injury during accidents and sudden stops. Mazda recommends that the driver and all passengers always wear seat belts. All the seats have lap/shoulder belts. These belts also have retractors with inertia locks that keep them out of the way when not in use. The locks allow the belts to remain comfortable on users, but they will lock in position during a collision.

Seat belts have 3 mechanisms.

ELR (emergency locking retractor) system

When the seat belt is fastened, it will always be in the emergency locking mode.

In the emergency locking mode, the belt remains comfortable on the occupant and the retractor will lock in position during a collision.

If the belt is locked and cannot be pulled out, retract the belt once, and then try pulling it out slowly. If this fails, pull the belt strongly 1 time and loosen, then pull it out again slowly.

Pretensioner system

If the vehicle receives a strong impact from the front or side of the vehicle, the system retracts the seat belts to increase their effect.

When a collision is detected, the pretensioners deploy simultaneously with the air bags.

The seat belt retractor quickly removes slack when an air bag is inflated.

The pretensioners deploy simultaneously with the air bags when a roll-over is also detected.

Load limiting system

If the vehicle receives a strong impact from the front of the vehicle, the load limiting system operates to prevent the seat belts from applying an excessive load. By maintaining the load applied to the seat belt to a specified level, the system reduces impact to an occupant's chest.

Even if the pretensioners have not fired, the load limiting function must be checked by an expert repairer (we recommend an Authorised Mazda Repairer).

NOTE

- The pretensioner system operates if the vehicle receives a strong impact from the vehicle front or side direction. The system may not operate if the impact is weak.
- Some smoke might be released when the pretensioner system operates, but this does not mean there is a fire. This gas normally has no effect on occupants. However, those with sensitive skin may experience light skin irritation. If residue from the operation of the pretensioner system gets on the skin or in the eyes, wash it off as soon as possible.

Seat Belts

Warnings and Cautions for Using the Seat Belts

WARNING

Always wear your seat belt and make sure all occupants are properly restrained.

Not wearing a seat belt is extremely dangerous. During a collision, occupants not wearing seat belts could hit someone or things inside the vehicle or even be thrown out of the vehicle. They could be seriously injured or even killed. In the same collision, occupants wearing seat belts would be much safer.

Do not wear twisted seat belts.

Twisted seat belts are dangerous. In a collision, the full width of the belt is not available to absorb the impact. This puts more force on the bones beneath the belt, which could cause serious injury or death. So, if your seat belt is twisted, you must straighten the seat belt to remove any twists and to allow the full width of the belt to be used.

Never use one seat belt on more than one person at a time.

Using one seat belt for more than one person at a time is dangerous. A seat belt used in this way cannot spread the impact forces properly and the two passengers could be crushed together and seriously injured or even killed. Never use one belt for more than one person at a time and always operate the vehicle with each occupant properly restrained.

Do not operate a vehicle with a damaged seat belt.

Using a damaged seat belt is dangerous. An accident could damage the belt webbing of the seat belt in use. A damaged seat belt cannot provide adequate protection in a collision. Have an expert repairer (we recommend an Authorised Mazda Repairer) inspect all seat belt systems in use during an accident before they are used again.

Have your seat belts changed immediately if the pretensioner or load limiter has been expended.

Always have an expert repairer (we recommend an Authorised Mazda Repairer) immediately inspect the seat belt pretensioners and air bags after any collision. Like the air bags, the seat belt pretensioners and load limiters will only function once and must be replaced after any collision that caused them to deploy. If the seat belt pretensioners and load limiters are not replaced, the risk of injury in a collision will increase.

Positioning the Shoulder Portion of the Seat Belt.

Improper positioning of the shoulder portion of the seat belt is dangerous. Always make sure the shoulder portion of the seat belt is positioned across your shoulder and near your neck, but never under your arm, on your neck, or on your upper arm.

Positioning the Lap Portion of the Seat Belt.

The lap portion of the seat belt worn too high is dangerous. In a collision, this would concentrate the impact force directly on the abdominal area, causing serious injury. Wear the lap portion of the belt snugly and as low as possible.

In a rollover crash, an unbelted person is significantly more likely to die than a person wearing a seat belt.

Instructions for Use of Seat Belt Assemblies.

Seatbelts are designed to bear upon the bony structure of the body, and should be worn low across the front of the pelvis or the pelvis, chest and shoulders, as applicable; wearing the lap section of the belt across the abdominal area must be avoided. Seatbelts should be adjusted as firmly as possible, consistent with comfort, to provide the protection for which they have been designed. A slack belt will greatly reduce the protection afforded to the wearer.

Care should be taken to avoid contamination of the webbing with polishes, oils and chemicals, and particularly battery acid. Cleaning may safely be carried out using mild soap and water. The belt should be replaced if webbing becomes frayed, contaminated or damaged.

It is essential to replace the entire assembly after it has been worn in a severe impact even if damage to the assembly is not obvious.

Belts should not be worn with straps twisted.

Each belt assembly must only be used by one occupant; it is dangerous to put a belt around a child being carried on the occupant's lap.

No modifications or additions should be made by the user which will either prevent the seat belt adjusting devices from operating to remove slack, or prevent the seat belt assembly from being adjusted to remove slack.

Pregnant women and persons with a medical condition should always wear seat belts.

However, ask your doctor about precautions in using a seat belt because a strong impact might be applied locally during sudden braking or a collision. The lap portion of the belt should fit the pelvis as low as possible avoiding abdominal area. In addition, the shoulder portion should be positioned on the shoulder and fitted to the chest avoiding the abdominal area.



Seat Belts

Wear seat belts only as recommended in this owner's manual.

Incorrect positioning of the seat belts is dangerous. Without proper positioning, the pretensioner and load limiting systems cannot provide adequate protection in an accident and this could result in serious injury. For more details about wearing seat belts, refer to "How to Use the Seat Belts" (page 3-21).

Have your seat belts changed immediately if the pretensioner or load limiter has been expended.

Always have an expert repairer (we recommend an Authorised Mazda Repairer) immediately inspect the seat belt pretensioners and air bags after any collision. Like the air bags, the seat belt pretensioners and load limiters will only function once and must be replaced after any collision that caused them to deploy. If the seat belt pretensioners and load limiters are not replaced, the risk of injury in a collision will increase.

Do not modify the components or wiring, or use electronic testing devices on the pretensioner system.

Modifying the components or wiring of the pretensioner system, including the use of electronic testing devices is dangerous. You could accidentally activate it or make it inoperable which would prevent it from activating in an accident. The occupants or person making the modification could be seriously injured.

Properly dispose of the pretensioner system.

Improper disposal of the pretensioner system or a vehicle with non-deactivated pretensioners is dangerous. Unless all safety procedures are followed, injury could result. Have an expert repairer (we recommend an Authorised Mazda Repairer) safely dispose of the pretensioner system or scrap a pretensioner system equipped vehicle.



Belt retraction may become difficult if the belts and rings are soiled, For more details about cleaning the seat belts, refer to "Seat Belt Maintenance" (page 9-65).

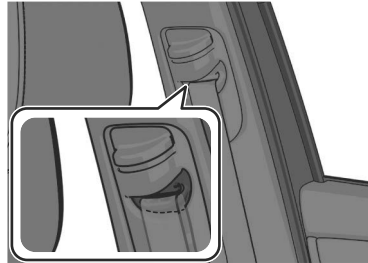

How to Use the Seat Belts

Fastening a Seat Belt

Before fastening a rear seat belt, make sure that the seat belt passes through the seat belt guide correctly and it is not twisted.

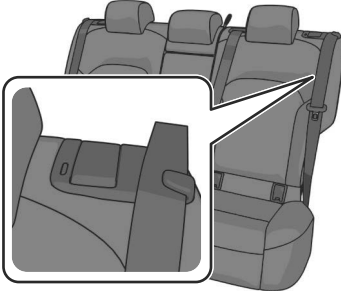

1. Sit back in the seat with your back upright.
2. Hold the plate and slowly pull out the seat belt.



NOTE

If the belt is locked and cannot be pulled out, retract the belt once, and then try pulling it out slowly. If this fails, pull the seat belt strongly one time and loosen it, then pull it out again slowly.

3. Make sure that the belt is not twisted.

4. Insert the plate into the buckle until it clicks.



5. The belt should fit the pelvis as low as possible.



6. The belt should not touch the neck, jaw, or face and it should pass over the shoulder.

Seat belt indicator light (rear seat) (green)

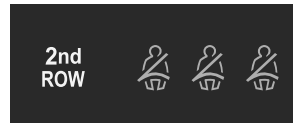

The light turns on when the rear seat belt is fastened while the vehicle power is switched ON, and it turns off after a certain period.

Seat Belts

Unfastening a Seat Belt

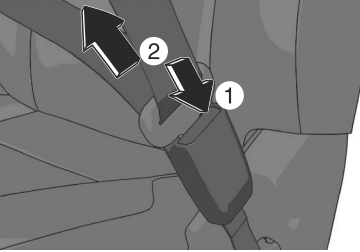

Make sure that the seat belt is not twisted, then let the seat belt retract slowly.

Adjusting the Seat Belt Height

If the seat belt contacts your neck or it slips off the shoulder, adjust the seat belt height.

To raise the seat belt

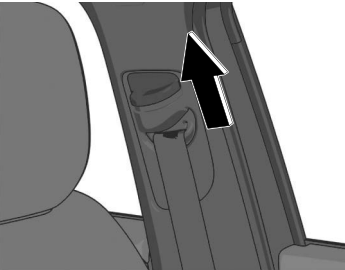

To lower the seat belt

1. Hold the seat belt anchor adjuster and press the knob down.

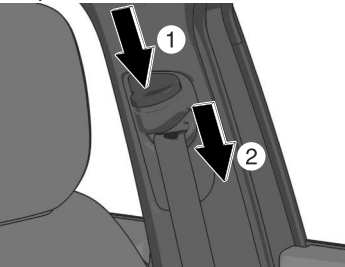

2. Make sure that the seat belt anchor adjuster is securely locked.

Warnings and Cautions for Using the Front Seats

WARNING

Never allow children to adjust a seat.

Allowing children to adjust a seat is dangerous as it could result in serious injury if a child's hands or feet become caught in the seat.

Do not drive with the seatback unlocked.

All of the seatbacks play an important role in your protection in a vehicle. Leaving the seatback unlocked is dangerous as it can allow passengers to be ejected or thrown around and baggage to strike occupants in a sudden stop or collision, resulting in severe injury. After adjusting the seatback at any time, even when there are no other passengers, rock the seatback to make sure it is locked in place.

Do not modify or replace the front seats.

Modifying or replacing the front seats such as replacing the upholstery or loosening any bolts is dangerous. The front seats contain air bag components essential to the supplementary restraint system. Such modifications could damage the supplementary restraint system and result in serious injury. Consult an expert repairer (we recommend an Authorised Mazda Repairer) if there is any need to remove or reinstall the front seats.

Adjust a seat only when the vehicle is stopped.

If the seat is adjusted while the vehicle is being driven, the seating posture may become unstable and the seat could move unexpectedly resulting in injury.

Do not drive with damaged front seats.

Driving with damaged front seats, such as seat cushions torn or damaged down to the urethane, is dangerous. A collision, even one not strong enough to inflate the air bags, could damage the front seats which contain essential air bag components. If there was a subsequent collision, an air bag may not deploy which could lead to injuries. Always have an expert repairer (we recommend an Authorised Mazda Repairer) inspect the front seats, front seat belt pretensioners and air bags after a collision.

Do not drive with either front seats reclined.

Sitting in a reclined position while the vehicle is moving is dangerous because you do not get the full protection from seat belts. During sudden braking or a collision, you can slide under the lap belt and suffer serious internal injuries. For maximum protection, sit well back and upright.

Front Seats

Do not place an object such as a cushion between the seatback and your back.

Putting an object such as a cushion between the seatback and your back is dangerous because you will be unable to maintain a safe driving posture and the seat belt cannot function at its full capacity in a collision, which could result in a serious accident, injury or death.

Do not place objects under the seat.

The object could get stuck and cause the seat to not be fixed securely, and result in an accident.

Do not stack cargo higher than the seatbacks.

Stacking luggage or other cargo higher than the seatbacks is dangerous. During sudden braking or a collision, objects can fly around and become projectiles that may hit and injure passengers.

Make sure the adjustable components of a seat are locked in place.

Adjustable seats and seatbacks that are not securely locked are dangerous. In a sudden stop or collision, the seat or seatback could move, causing injury. Make sure the adjustable components of the seat are locked in place by attempting to slide the seat forward and backward and rocking the seatback.

Make sure luggage and cargo is secured before driving.

Not securing cargo while driving is dangerous as it could move or be crushed during sudden braking or a collision and cause injury.

Additionally, if the air bags deploy, the cargo may scatter which could result in serious injury or death.

Never allow a passenger to sit or stand on the folded seatback while the vehicle is moving.

Driving with a passenger on the folded seatback is dangerous. Allowing a child to sit up on the folded seatback while the vehicle is moving is particularly dangerous. In a sudden stop or even a minor collision, a child not in a proper seat or child-restraint system and seat belt could be thrown forward, back or even out of the vehicle resulting in serious injuries or death. The child in the baggage area could be thrown into other occupants and cause serious injury.

 **CAUTION**

- When operating a seat, be careful not to put your hands or fingers near the moving parts of the seat or on the side trim to prevent injury.
- When moving the seats, make sure there is no cargo in the surrounding area. If the cargo gets caught it could damage the cargo.
- **(Manual Seat)**
When moving the seats forward and rearward or returning a rear-reclined seatback to its upright position, make sure you hold onto the seatback with your hand while operating. If the seatback is not held, the seat will move suddenly and could cause injury.

➤ When inserting your hand under the seat to clean the cabin or pick up something you dropped under the seat, be careful not to hurt yourself. If you contact the moving parts and surrounding parts around the seat rail, seat frame, and the bottom of the seat, it could result in injury.

How to Use the Front Seats

Driver's Seat

Manual seat

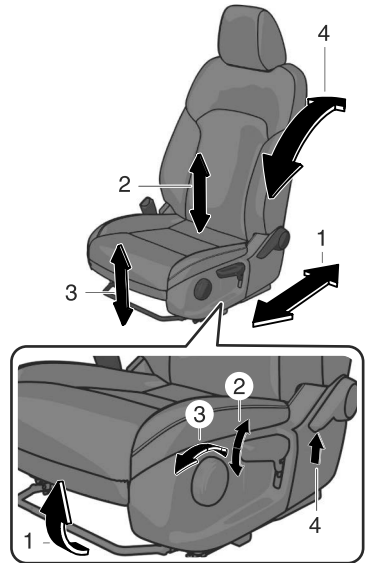

1. Seat Slide
2. Height Adjustment
3. Height Adjustment for Front Edge of Seat Bottom*
4. Seat Recline

Power seat

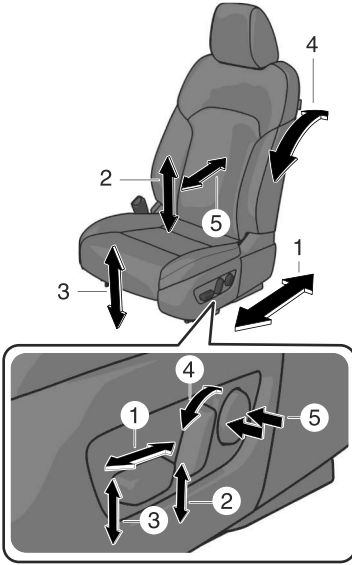

1. Seat Slide
2. Height Adjustment
3. Height Adjustment for Front Edge of Seat Bottom
4. Seat Recline
5. Lumbar Support Adjustment

Passenger's seat
Manual seat

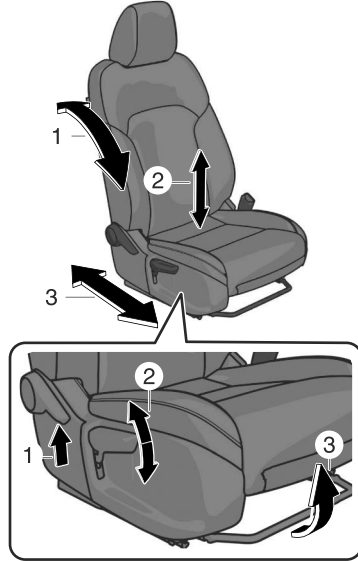

1. Seat Recline
2. Height Adjustment
3. Seat Slide

Power seat

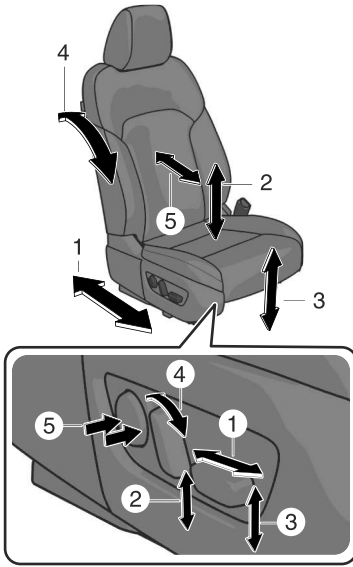

1. Seat Slide
2. Height Adjustment
3. Height Adjustment for Front Edge of Seat Bottom
4. Seat Recline
5. Lumbar Support Adjustment*

Driving Position Memory*

The desired driving position can be called up after programming the position.

- Driver's seat position (Seat slide, height adjustment, front edge of seat bottom, seat recline)
- Active driving display (Display position, brightness level, display information)
- Outside mirror angle
- Steering Wheel (Power type) (Up and down adjustment, forward and backward adjustment)

Warnings and Cautions for Using the Driving Position Memory

CAUTION

Do not place hand, fingers, or feet around the bottom of the seat or around the bottom of the steering wheel while the seat memory function is operating. The seat or steering wheel moves automatically while the seat memory function is operating and hand, fingers, or feet could get pinched and injured.

How to Use the Driving Position Memory

A driving position can be programmed to the position memory switch and the key.

Programming

1. Switch the vehicle power ON.
2. Adjust the following driving positions to the desired positions.
 - Driver's seat
 - Active driving display
 - Outside mirrors
 - Steering wheel (Power type)
3. Continue pressing the SET switch until a sound is activated.

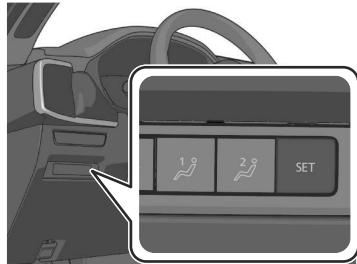

4. Do the following operation within 5 seconds after the sound is activated to programme the driving position.
 - **Programming to a position memory button**
Press the button you want to programme, either 1 or 2 button.



- **Programming to the transmitter**
Press the unlock button on the transmitter.

A sound is activated when the operation is completed correctly.

Adjusting to the Programmed Driving Position

Operation Using the Position Memory Switch

Press either switch 1 or 2 that you programmed to activate the seat adjustment to your position.

A sound is activated when the adjustment to the programmed driving position is completed.

Operation Using the Key

1. Unlock the driver's door using one of the following methods.
 - Touch the sensing area of the door release touch sensor.
 - Press the key unlock button.
2. If the driver's door is opened within a certain period of time after unlocking, adjustment of the next driving position starts.
 - Driver's seat
 - Active driving display
 - Outside mirrors
 - Steering wheel (Power type)

A sound is activated when the adjustment to the programmed driving position is completed.

Deleting a Programmed Position

Erasing the Position Stored in the Position Memory Switch

Programme a new driving position.

Deleting a Position Programmed to the Key

1. Switch the vehicle power OFF.
2. Continue pressing the SET switch until a sound is activated.
3. Press the key lock button within 5 seconds after the sound is activated.

NOTE

- If the angle of the outer mirror is adjusted close to the limits of its range of motion, the angle of the outer mirrors may not be programmed correctly.
- When the adjustment to the programmed driving position has been completed, a sound is not activated.
- Under the following conditions, the driving position adjustment is cancelled.
 - The seat adjustment switch/SET switch/steering wheel (power type)/outer mirrors/active driving display for the driver's seat is operated to adjust the position.
 - The key lock button or unlock button is operated.
 - The vehicle moves.
 - The selector lever is shifted to a position other than P.

Rear Seats

Warnings and Cautions for Using the Rear Seats

! WARNING

Do not drive the vehicle with occupants on folded down seatbacks or in the luggage compartment.

Putting occupants in the luggage compartment is dangerous because seat belts cannot be fastened which could lead to serious injury or death during sudden braking or a collision.

Do not allow children to play inside the vehicle with the seatbacks lowered.

Allowing children to play in the vehicle with the seatbacks folded down is dangerous. If a child enters the luggage compartment and the seatbacks were raised back up, the child may become trapped in the luggage compartment which could lead to an accident.

Tightly secure cargo in the luggage compartment when it is transported with the seatbacks folded down.

Driving without tightly securing cargo and luggage is dangerous as it could move and become an obstruction to driving during emergency braking or a collision resulting in an unexpected accident.

When transporting cargo, do not allow the cargo to exceed the height of the seatbacks.

Transporting cargo stacked higher than the seatbacks is dangerous as visibility to the rear and sides of the vehicle is reduced which could interfere with driving operations and lead to an accident.

When returning a seatback to its upright position, make sure the 3-point seat belt is not caught in the seatback and the 3-point seat belt is not twisted.

If the seat belt is used while it is twisted and caught in the seatback, the seat belt cannot function at its full capacity, which could cause serious injury or death.

When returning a seatback to its upright position, make sure that it is firmly locked and the red indication is not visible.

If the red indication is visible, it means the seatback is not locked. If the vehicle is driven without the seatback locked, it could fold down suddenly and cause an accident.

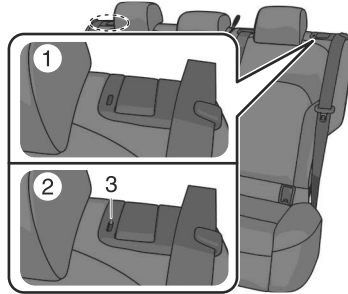

1. Locked position
2. Unlocked position
3. Red indication

Always remove the child-restraint system from the rear seat before operating the remote handle for the rear seat.

Operating the remote handle while a rear-facing child-restraint system is in the rear seat is dangerous. It could cause injury to a child seated in the child-restraint system when the seatback suddenly flips forward.

Make sure there is nobody in the rear seat area before operating (pulling) the remote handle.

Not checking the rear seat area for persons before folding the seatbacks with the strap/remote handle is dangerous. The rear seat area is difficult to see from the rear of the vehicle. Operating (pulling) the remote handle without checking could cause injury to a person when a seatback suddenly flips forward.

⚠ CAUTION

- When folding the seatback forward, always support the seatback with your hand. If it is not supported by a hand, the seatback will move suddenly and could cause injury.
- Check the position of a front seat before folding a rear seatback. Depending on the position of a front seat, it may not be possible to fold a rear seatback all the way down because it may hit the seatback of the front seat which could scratch or damage the front seat or its pocket. Lower or remove the head restraint on the rear outboard seat if necessary.
- Before folding the seatbacks down with the remote handle, make sure there is no cup in a rear cup holder. Folding the seatbacks with the remote handle while a cup is in the cup holder could soil or damage the seat bottom and seatback.
- Be careful of the following when using the remote handle:
 - On a downward slope, the seatback could flip forward faster than on a flat surface.

- On an upward slope, the seatback may not fold down. When the seatbacks cannot be folded down with the remote handle, pull the rear seatback forward from inside the vehicle.

➤ **(Folding the left seatback)**

Be careful when operating the remote handle with the centre seatback folded down. If a person sitting in the right rear seat places a hand on the centre seatback, it could be pinched by a seatback or seat component causing injury.

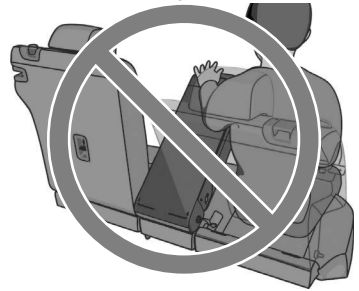

How to Use the Rear Seats

Reclining the Seatbacks

1. Recline the seatback with the lever pulled up.
2. Return the lever to lock it. Make sure no red indication is visible.

The left and right seatbacks of the rear seat can be adjusted separately.

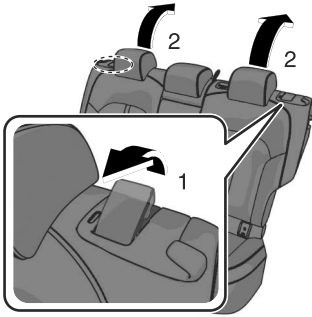

Raising the Seatbacks

1. Make sure that the seat belt is correctly routed through the seat belt guide and it is not twisted.

2. Raise the seatback with the lever pulled while preventing the seat belt from being caught.

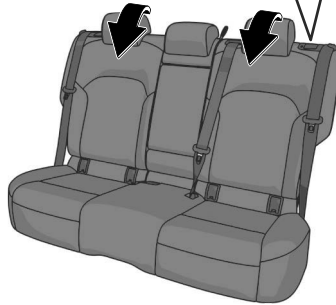
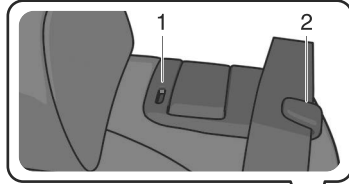

1. Red indication
2. Seat belt guide
3. Return the lever and tilt the seatback rearward to lock it.
4. Make sure that the red indication is not visible.

Folding the Seatbacks*

(Using remote handle)

1. After checking that the rear seats are clear, open the liftgate and lower the seatback you want to fold down using the remote handle. When folding the left side, operate the outer part of the remote handle.

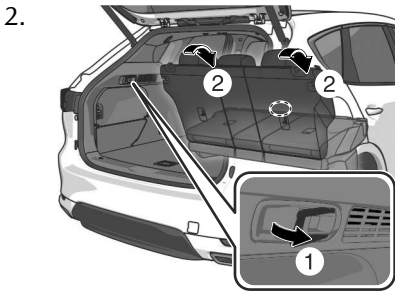

(Using the lever)

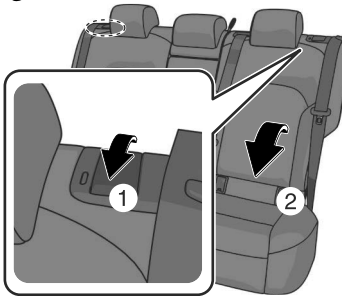

Raising the Seatbacks

1. Make sure that the seat belt is correctly routed through the seat belt guide and it is not twisted.

2. Raise the seatback while preventing the seat belt from being caught.

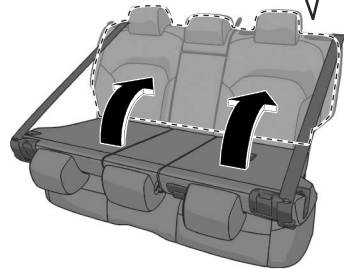
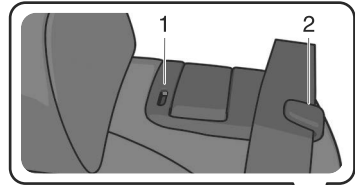

1. Red indication
2. Seat belt guide
3. Push the seatback rearward until it locks.
4. Make sure that the red indication is not visible.

Folding only centre seatback*

(Using remote handle)

1. If the centre head restraint is in the position for use, store it.
2. After checking that the centre seat is clear, open the liftgate and pull the inside remote handle on the left side of the liftgate compartment.

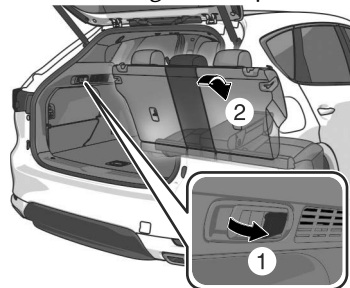

Rear Seats

(Using strap)

1. If the centre head restraint is in the position for use, store it.
- 2.

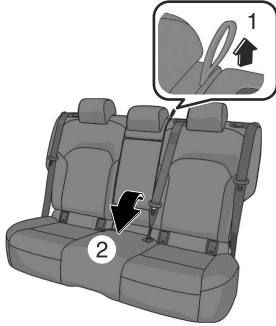

Raising the centre seatback

- 1.

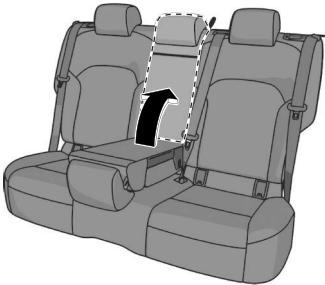

2. Push the centre seatback rearward until it locks.

Warnings and Cautions for Using the Armrests

WARNING

Never put your hands and fingers around the moving parts of the seat and armrest.

Putting your hands and fingers around the moving parts of the seat and armrest is dangerous as they could get injured.

How to Use the Armrests



Head Restraints

Head Restraints

Your vehicle is equipped with head restraints on all outboard seats and the rear centre seat.

The head restraints are intended to help protect you and the passengers from neck injury.

Warnings and Cautions for Using the Head Restraints

WARNING

Always drive with the head restraints installed when seats are being used and make sure they are properly adjusted.

Driving with the head restraints adjusted too low or removed is dangerous. With no support behind your head, your neck could be seriously injured in a collision.

After installing a head restraint, try lifting it to make sure that it does not pull out.

Driving with an unsecured head restraint is dangerous as the effectiveness of the head restraint will be compromised which could cause it to unexpectedly detach from the seat.

! CAUTION

- When installing a head restraint, make sure that it is installed correctly with the front of the head restraint facing forward. If the head restraint is installed incorrectly, it could detach from the seat during a collision and result in injury.
- The head restraints on each of the front and rear seats are specialized to each seat. Do not switch around the head restraint positions. If a head restraint is not installed to its correct seat position, the effectiveness of the head restraint during a collision will be compromised which could cause injury.

How to Use the Head Restraints

Adjusting the Head Restraints

Adjust the head restraint so that the centre is even with the top of the passenger's ears.

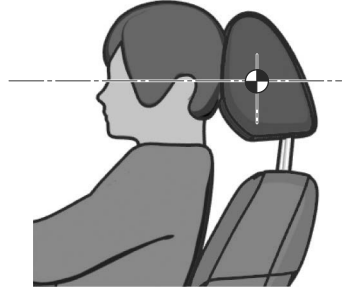

To Raise a Head Restraint

Pull up a head restraint.

To Lower a Head Restraint

Lower a head restraint while pressing the lock knob.

Front seats

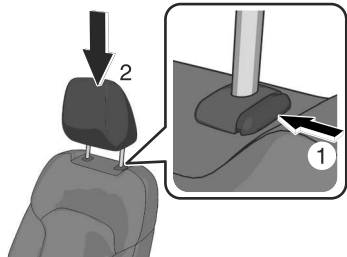

Head Restraints

Rear seats (Centre/Left/Right seats)

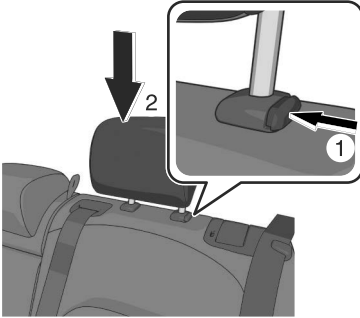

Removing or Installing a Head Restraint

To Remove a Head Restraint

Pull up a head restraint while pressing the lock knob.

To Install a Head Restraint

Insert a head restraint while pressing the lock knob.

Warnings and Cautions for Using the Steering Wheel

WARNING

Never adjust the steering wheel while the vehicle is moving.

Adjusting the steering wheel while the vehicle is moving is dangerous. Moving it can very easily cause the driver to abruptly turn to the left or right. This can lead to loss of control or an accident.

After adjusting the steering wheel position, make sure it is securely locked by trying to move it up and down.

Driving with the steering wheel not securely locked in position is dangerous. If the steering wheel moves unexpectedly while driving, you could lose control of the steering resulting in an accident.

How to Use the Steering Wheel

Manual Type

1.



2. Adjust the steering wheel to the appropriate position.

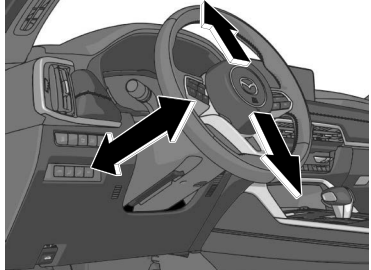

3. Pull up the lever to securely lock the steering wheel.

Power Type

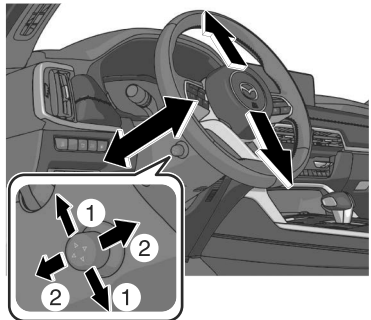

1. Up and down adjustment

2. Forward and backward adjustment

Child-restraint Systems

Child-restraint Systems

Mazda strongly urges the use of child-restraint systems for children small enough to use them.

Mazda recommends use of a Mazda genuine child-restraint system or one that complies with the UN-R^{*1} 44 or UN-R 129 regulation. If you would like to purchase a Mazda genuine child-restraint system, please contact an expert repairer (we recommend an Authorised Mazda Repairer). Check your local and state or provincial laws for specific requirements regarding the safety of children riding in your vehicle.

*1 UN-R stands for United Nations Regulation.

Whatever child-restraint system you consider, please pick the appropriate one for the age and size of the child, obey the law and follow the instructions that come with the individual child-restraint system.

A child who has outgrown child-restraint systems should sit in the rear and use seat belts.

The child-restraint system should be installed on the rear seat. Statistics confirm that the rear seat is the best place for all children up to 12 years of age—the more so with a supplementary restraint system (air bags).

A rear-facing child-restraint system should **NEVER** be used in the front passenger seat with the air bag system activated. The front passenger's seat is also the least preferred seat for other child-restraint systems.

Warnings and Cautions For Child-restraint Systems

WARNING

Use the correct size child-restraint system.

For effective protection in vehicle accidents and sudden stops, a child must be properly restrained using a seat belt or child-restraint system depending on age and size. If not, the child could be seriously injured or even killed in an accident.

Follow the manufacturer's instructions and always keep the child-restraint system buckled down.

An unsecured child-restraint system is dangerous. In a sudden stop or a collision it could move causing serious injury or death to the child or other occupants. Make sure any child-restraint system is properly secured in place according to the child-restraint system manufacturer's instructions. When not in use, remove it from the vehicle or fasten it with a seat belt, or latch it down to BOTH ISOFIX anchors, and attach the corresponding tether anchor.

Always secure a child in a proper child-restraint system.

Holding a child in your arms while the vehicle is moving is extremely dangerous. No matter how strong the person may be, he or she cannot hold onto a child in a sudden stop or collision and it could result in serious injury or death to the child or other occupants. Even in a moderate accident, the child may be exposed to air bag forces that could result in serious injury or death to the child, or the child may be slammed into an adult, causing injury to both child and adult.

Extreme Hazard! Never use a rear-facing child-restraint system on the front passenger seat with an air bag that could deploy.

NEVER use a rearward facing child restraint on a seat protected by an ACTIVE AIRBAG in front of it, DEATH or SERIOUS INJURY to the CHILD can occur.

Vehicles with a front passenger air bag have the following warning label. The warning label reminds you not to put a rear-facing child-restraint system on the front passenger seat at any time.

(Europe and other countries (Except Taiwan))

NEVER use a rearward facing child restraint on a seat protected by an ACTIVE AIRBAG in front of it, DEATH or SERIOUS INJURY to the CHILD can occur.



(Taiwan Only)



依規定前排座椅禁止乘載嬰兒、幼童及兒童。

Even in a moderate collision, the child-restraint system can be hit by a deploying air bag and moved violently resulting in serious injury or death to the child.



(Taiwan, except front passenger seat, if equipped with the following label)

NEVER use a rearward facing child restraint on a seat protected by an ACTIVE AIRBAG in front of it, DEATH or SERIOUS INJURY to the CHILD can occur.



Child-restraint Systems

Do not install a front-facing child-restraint system on the front passenger seat unless it is unavoidable.

In a collision, the force of a deploying air bag could cause serious injury or death to the child. If installing a front-facing child-restraint system on the front passenger seat is unavoidable, move the front passenger seat as far back as possible.



Seating a child in a child-restraint system on the front passenger seat is dangerous under certain conditions (With Front Passenger Occupant Classification System).

Your vehicle is equipped with front passenger occupant classification sensor. Even with the front passenger occupant classification sensor, if you must use the front passenger seat to seat a child, using a child-restraint system on the front passenger seat under the following conditions increases the danger of the front passenger air bag deploying and could result in serious injury or death to the child.

- The front passenger air bag deactivation OFF indicator light does not illuminate when seating a child in the child-restraint system.
- Luggage or other items are placed on the seat with the child in the child-restraint system.
- A rear passenger or luggage pushing or pulling down on the front passenger seatback.
- Luggage or other items are placed on the seatback or hung on the head restraint.
- The seat is washed.
- Liquids are spilled on the seat.
- The front passenger seat is moved backward, pushing into luggage or other items placed behind it.
- The front passenger seatback contacts the rear seat.
- Luggage or other items are placed between the front passenger seat and driver seat.
- An electric device is put on the front passenger's seat.
- An additional electrical device, such as a seat warmer is installed to the surface of the front passenger seat.

The designated positions with seat belts on the rear seats are the safest places for children. Always use seat belts and child restraints.

Do not allow a child or anyone to lean over to or against the side window of a vehicle with side and curtain air bags.

It is dangerous to allow anyone to lean over to or against the side window, the area of the front passenger seat, the front and rear window pillars and the roof edge along both sides from which the side and curtain air bags deploy, even if a child-restraint system is used. The impact of inflation from a side or curtain air bag could cause serious injury or death to an out of position child. Furthermore, leaning over to or against the door could block the side and curtain air bags and eliminate the advantages of supplementary protection. Because the front seats are equipped with front air bags, the rear seat is always a better location for children. Take special care not to allow a child to lean over to or against the side window, even if the child is seated in a child-restraint system.

Never use one seat belt on more than one person at a time.

Using one seat belt for more than one person at a time is dangerous. A seat belt used in this way cannot spread the impact forces properly and the two passengers could be crushed together and seriously injured or even killed. Never use one belt for more than one person at a time and always operate the vehicle with each occupant properly restrained.

Use the tether and tether anchor only for a child-restraint system.

Child-restraint system anchorages are designed to withstand only those loads imposed by correctly installed child-restraint systems. Under no circumstances are they to be used for adult seat belts, harnesses, or for attaching other items or equipment to the vehicle.

Always route the tether strap between the head restraint and the seatback.

Routing the tether strap on top of the head restraint is dangerous. In a collision the tether strap could slide off the head restraint and loosen the child-restraint system. The child-restraint system could move which may result in death or injury to the child.

Always attach the tether strap to the correct tether anchor position.

Attaching the tether strap to the incorrect tether anchor position is dangerous. In a collision, the tether strap could come off and loosen the child-restraint system. If the child-restraint system moves it could result in death or injury to the child.

Always remove the head restraint and set the tether strap (except when installing a booster seat).

Routing the tether strap on top of the head restraint is dangerous. In a collision the tether strap could slide off the head restraint and loosen the child-restraint system. The child-restraint system could move which may result in death or injury to the child.

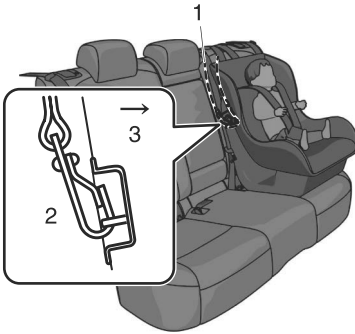

1. Tether strap
2. Anchor bracket
3. Forward

Follow the manufacturer's instructions for the use of the child-restraint system.

An unsecured child-restraint system is dangerous. In a sudden stop or a collision it could move causing serious injury or death to the child or other occupants. Make sure any child-restraint system is properly secured in place according to the manufacturer's instructions.

Using ISO-FIX anchor

Make sure the child-restraint system is properly secured.

A child-restraint system that is not secured is dangerous. In a sudden stop or collision, it can become a projectile and hit someone, causing serious injury. When not in use, remove it from the vehicle, put it in the luggage compartment or at least make sure it is securely fastened to the ISOFIX anchors.

Make sure there are no seat belts or foreign objects near or around the ISOFIX anchor-secured child-restraint system.

Not following the child-restraint system manufacturer's instructions when installing the child-restraint system is dangerous. If seat belts or a foreign object prevent the child-restraint system from being securely attached to the ISOFIX anchors and the child-restraint system is installed improperly, the child-restraint system could move in a sudden stop or collision causing serious injury or death to the child or other occupants. When installing the child-restraint system, make sure there are no seat belts or foreign objects near or around the ISOFIX anchors. Always follow the child-restraint system manufacturer's instructions.

Always remove the head restraint and install child-restraint system.

Installing a child-restraint system without removing the head restraint is dangerous. The child-restraint system cannot be installed correctly which may result in death or injury to the child in a collision.

Always install the head restraint and adjust it to the appropriate position after removing the child-restraint system.

Driving with the head restraint removed is dangerous as impact to the occupant's head cannot be prevented during emergency braking or in a collision, which could result in a serious accident, injury or death.

To avoid burning yourself or a child, check them before you or your child touches them.

A seat belt or child-restraint system can become very hot in a closed vehicle during warm weather.

Types of Child-restraint Systems

Categories of Child-Restraint Systems

NOTE

When purchasing, ask the manufacturer of the child-restraint system which type of child-restraint system is appropriate for your child and vehicle.

(Europe and countries conforming to the UN-R 44 and UN-R 129 regulation)

Child-restraint systems are classified into the following 5 groups according to the UN-R 44 and UN-R 129 regulation.

Group	Age	Weight	Size Classification/ Fixture (CRF)
0	Up to about 9 months old	Up to 10 kg (up to 22 lb)	ISO/L1
			ISO/L2
			ISO/R1
0+	Up to about 2 years old	Up to 13 kg (up to 29 lb)	ISO/R1
			ISO/R2
			ISO/R3
1	About 8 months to 4 years old	9 kg — 18 kg (20 lb — 40 lb)	ISO/R2
			ISO/R3
			ISO/F2
			ISO/F2X
2	About 3 to 7 years old	15 kg — 25 kg (33 lb — 55 lb)	ISO/F3
			—
3	About 6 to 12 years old	22 kg — 36 kg (48 lb — 79 lb)	—

(Other countries)

Please comply with the legal regulations concerning the use of child-restraint systems in your country.

Child-Restraint System Types

(Europe and countries conforming to the UN-R 44 and UN-R 129 regulation)

In this owner's manual, explanation of child-restraint systems secured with seat belts is provided for the following 3 types of popular child-restraint systems: baby seat, child seat, junior seat.

NOTE

- Installation position is determined by the type of child-restraint system. Always read the manufacturer's instructions and this owner's manual carefully.

- Due to variations in the design of child-restraint systems, vehicle seats and seat belts, all child-restraint systems may not fit all seating positions. Before purchasing a child-restraint system, it should be tested in the specific vehicle seating position (or positions) where it is intended to be used. If a previously purchased child-restraint system does not fit, you may need to purchase a different one that will.

Baby seat

Equal to Group 0 and 0+ of the UN-R 44 and UN-R 129 regulation.

(Europe)

Recommended child-restraint system: Britax Römer BABY-SAFE 3 i-SIZE and FLEX BASE i-SENSE



Child seat

Equal to Group 1 of the UN-R 44 and UN-R 129 regulation.

(Europe)

Recommended child-restraint system: Britax Römer TRIFIX 2 i-SIZE



Junior seat

Equal to Group 2 and 3 of the UN-R 44 and UN-R 129 regulation.

Child-restraint Systems

(Europe)

Recommended child-restraint system: Britax Römer KIDFIX i-SIZE



When using the KIDFIX i-SIZE, make sure that the shoulder belt passes through the shoulder belt pad (XP-PAD), and the lap belt passes through the lap belt guide (SecureGuard).

For details on use, refer to the user manual accompanying the KIDFIX i-SIZE.

(Other countries)

Please comply with the legal regulations concerning the use of child-restraint systems in your country.

Child-restraint System Installation

Baby Seat Installation Position

A baby seat is used in the rear-facing position only.

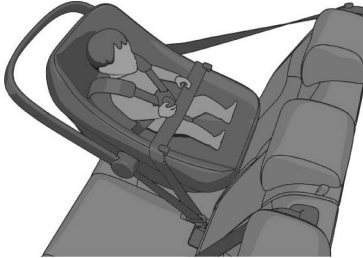

Refer to the table, "Child-Restraint System Suitability for Various Seat Positions" for baby seat installation position (Page 3-53).

WARNING

Always install a baby seat in the correct seat position.

Installing a baby seat without first consulting the table "Child-Restraint System Suitability for Various Seat Positions" is dangerous. A baby seat installed on the wrong seat position cannot be properly secured. In a collision, the child could hit something or someone in the vehicle and be seriously injured or even killed.

Never use a rear-facing child-restraint system on the front passenger seat protected by an air bag.

NEVER use a rearward facing child restraint on a seat protected by an ACTIVE AIRBAG in front of it, DEATH or SERIOUS INJURY to the CHILD can occur. The child-restraint system can be hit by the deploying air bag and knocked out of position. A child in the child-restraint system could be seriously injured or killed. When installing a rear-facing child-restraint system, make sure that the air bag system is turned off.



Child-restraint Systems

Child Seat Installation Position

A child seat is used in front-facing and rear-facing positions depending on the age and size of the child. When installing, follow the manufacturer's instructions in accordance with the appropriate age and size of the child as well as the directions for installing the child-restraint system.

Refer to the table, "Child-Restraint System Suitability for Various Seat Positions" for child seat installation position (Page 3-53).

Rear-facing type



Always install a baby seat in the correct seat position.

Installing a baby seat without first consulting the table "Child-Restraint System Suitability for Various Seat Positions" is dangerous. A baby seat installed on the wrong seat position cannot be properly secured. In a collision, the child could hit something or someone in the vehicle and be seriously injured or even killed.

Never use a rear-facing child-restraint system on the front passenger seat protected by an air bag.

NEVER use a rearward facing child restraint on a seat protected by an ACTIVE AIRBAG in front of it, DEATH or SERIOUS INJURY to the CHILD can occur. The child-restraint system can be hit by the deploying air bag and knocked out of position. A child in the child-restraint system could be seriously injured or killed. When installing a rear-facing child-restraint system, make sure that the air bag system is turned off.



Front-facing type



Never install a front-facing child seat in the wrong seat position.

Installing a front-facing child seat without first consulting the table "Child-Restraint System Suitability for Various Seat Positions" is dangerous. A front-facing child seat installed in the wrong seat position cannot be properly secured. In a collision, the child could hit something or someone in the vehicle and be seriously injured or even killed.

Do not install a front-facing child-restraint system on the front passenger seat unless it is unavoidable.

In a collision, the force of a deploying air bag could cause serious injury or death to the child. If installing a front-facing child-restraint system on the front passenger seat is unavoidable, move the front passenger seat as far back as possible and adjust the seat bottom (height adjustable seat bottom) to the highest position at which the seat belt fastening the child-restraint system is securely tightened.



Junior Seat Installation Position

A junior seat is used in the front-facing position only.

We recommend the use of the junior seat with backrest to allow simple adjustment of the shoulder belt position and to give your child the best protection.

When using a booster seat, always install the vehicle head restraint to the seat where the booster seat is installed.



Refer to the table, "Child-Restraint System Suitability for Various Seat Positions" for junior seat installation position (Page 3-53).

Child-restraint Systems

WARNING

Always install a junior seat in the correct seat position.

Installing a junior seat without first consulting the table “Child-Restraint System Suitability for Various Seat Positions” is dangerous. A junior seat installed on the wrong seat position cannot be properly secured. In a collision, the child could hit something or someone in the vehicle and be seriously injured or even killed.

Do not install a front-facing child-restraint system on the front passenger seat unless it is unavoidable.

In a collision, the force of a deploying air bag could cause serious injury or death to the child. If installing a front-facing child-restraint system on the front passenger seat is unavoidable, move the front passenger seat as far back as possible and adjust the seat bottom (height adjustable seat bottom) to the highest position at which the seat belt fastening the child-restraint system is securely tightened.



Using the Seat Belt

When installing a child-restraint system, follow the installation instructions included with the product.

In addition, remove the head restraint. However, when installing a booster seat, always install the vehicle head restraint to the seat where the booster seat is installed.

If the rear seat is reclined, return it to the upright position.

Child-Restraint System Suitability for Various Seat Positions Table

(Europe and countries conforming to the UN-R 16 regulation)

Provided information in the table shows your child-restraint system suitability for various seating position. For installation suitability of other manufacturer child-restraint system, carefully consult the manufacturer's instructions which accompany the child-restraint system.

When installing a child-restraint system, the following points must be observed:

- Always remove the head restraint before installing a child-restraint system. However, when installing a booster seat, always install the vehicle head restraint to the seat where the booster seat is installed. In addition, always use a tether strap and attach it securely. Refer to Head Restraints on page 3-36.
- When installing a child-restraint system to the front passenger seat, adjust the seat slide position as far back as possible. Adjust the seat bottom (height adjustable seat bottom) to the highest position so that the seat belt can securely fasten the child-restraint system.
- When it is difficult to install a child-restraint system to the front passenger seat, or the seat belt cannot be secured to the child-restraint system, perform the following operations to adjust the seat holding the child-restraint system so that the seat belt can be secured completely to it.
 - Move the seat forward or back.
 - Move the seatback forward or back.
 - Move the seat upward or downward.
- When installing a child-restraint system to the rear seat, adjust the front seat position so that the front seat does not contact the child-restraint system. Refer to How to Use the Front Seats on page 3-25. If the rear seat is reclined, return it to the upright position.
- A child-restraint system with a support leg cannot be installed on the rear centre seat position.
- When installing a child-restraint system equipped with a tether, remove the head restraint. Refer to Head Restraints on page 3-36.
- An i-Size child-restraint system refers to a child-restraint system which has acquired i-Size category certification for the UN-R 129 regulation.

When installing a child-restraint system to the rear seat, refer to the child-restraint system manufacturer's instructions and the Child-restraint System Installation on page 3-49.

Child-restraint Systems

Europe and other countries (Except Taiwan)

Seating position	Passenger		Rear (Left)	Rear (Centre)	Rear (Right)
	Air bag activated	Air bag de-activated			
Seating position suitable for universal belted (Yes/No)	Yes (UF)	Yes (U)	Yes (U)	Yes (U)	Yes (U)
i-Size seating position (Yes/No)	No	No	Yes (i-U)	No	Yes (i-U)
Largest suitable rearward facing fixture (R1)	No	No	Yes (IL)	No	Yes (IL)
Largest suitable rearward facing fixture (R2)	No	No	Yes (IL)	No	Yes (IL)
Largest suitable rearward facing fixture (R2X)	No	No	Yes (IL)	No	Yes (IL)
Largest suitable rearward facing fixture (R3)	No	No	Yes (IL)	No	Yes (IL)
Largest suitable forward facing fixture (F2)	No	No	Yes (IUF)	No	Yes (IUF)
Largest suitable forward facing fixture (F2X)	No	No	Yes (IUF)	No	Yes (IUF)
Largest suitable forward facing fixture (F3)	No	No	Yes (IUF)	No	Yes (IUF)
Largest suitable lateral facing fixture (L1)	No	No	No	No	No
Largest suitable lateral facing fixture (L2)	No	No	No	No	No
Largest suitable booster fixture (B2)	No	No	Yes (IUF)	No	Yes (IUF)

Seating position	Passenger		Rear (Left)	Rear (Centre)	Rear (Right)
	Air bag activated	Air bag deactivated			
Largest suitable booster fixture (B3)	No	No	Yes (IUF)	No	Yes (IUF)
Non i-size compatible with a support leg (Yes/No)	Yes ^{*1}	Yes	Yes	No	Yes
Lower ISOFIX anchorages but without Top Tether (Yes/No)	No	No	No	No	No

U = Suitable for “universal” category restraints approved for use in all mass groups.

UF = Suitable for forward-facing “universal” category restraints approved for use in all mass groups.

IUF = Suitable for ISOFIX forward child restraint systems of universal category approved for use in the mass group.

L = Suitable for particular child restraints given on attached list. These restraints may be of the “specific vehicle”, “restricted” or “semi-universal” categories.^{*2}

IL = Suitable for particular ISOFIX child restraint systems (CRS) given in the attached list. These ISOFIX CRS are those of the “specific vehicle”, “restricted” or “semi-universal” categories.^{*2}

i-U = Suitable for i-Size “universal” Child Restraint Systems forward and rearward facing.

i-UF = Suitable for forward-facing i-Size “universal” Child Restraint Systems only.

Yes = Child-restraint system can be secured on the seat.

No = Child-restraint system cannot be secured on the seat, or there is no fixture.

X = Child-restraint system cannot be installed.

^{*1} Child restraint system can only be installed in the forward-facing position.

^{*2} A Mazda genuine child-restraint system can be installed. Regarding child-restraint systems which can be installed, refer to Types of Child-restraint Systems on page 3-46 or the accessories catalog.

The manufacturer will also recommend a suitable ISOFIX child restraint system.

For this, your vehicle and the seat must be listed on the child restraint system manufacturer's model list.

For more information, contact the child restraint system manufacturer or visit the manufacturer's website.

Taiwan Only

ISOFIX anchor-secured child-restraint systems

Mass group	Size Class	Fixture	Seat Positions		
			Vehicle ISOFIX positions	Rear seat (centre)	Front passenger seat (outboard)
Carycot	F	ISO/L1	X	X	X
	G	ISO/L2	X	X	X
		(1)	X	X	X
GROUP 0 Up to 10 kg (up to 22 lb)	E	ISO/R1	IL	X	X
		(1)	X	X	X
GROUP 0+ Up to 13 kg (up to 29 lb)	E	ISO/R1	IL	X	X
	D	ISO/R2	IL	X	X
	C	ISO/R3	IL	X	X
		(1)	X	X	X
GROUP 1 9 kg — 18 kg (20 lb — 40 lb)	D	ISO/R2	IL	X	X
	C	ISO/R3	IL	X	X
	B	ISO/F2	IUF	X	X
	B1	ISO/F2X	IUF	X	X
	A	ISO/F3	IUF	X	X
		(1)	X	X	X
GROUP 2 15 kg — 25 kg (33 lb — 55 lb)		(1)	X	X	X
GROUP 3 22 kg — 36 kg (48 lb — 79 lb)		(1)	X	X	X

(1) For the CRS which do not carry the ISO/XX size class identification (A to G), for the applicable mass group, the car manufacturer shall indicate the vehicle specific ISOFIX child-restraint system(s) recommended for each position.

Key of letters to be inserted in the above table:

IUF = suitable for ISOFIX forward child-restraints systems of universal category approved for use in this mass group.

IL = suitable for particular ISOFIX child-restraint systems (CRS).

These ISOFIX CRS are those of the “specific vehicle”, “restricted” or “semi-universal” categories.

A Mazda genuine child-restraint system can be installed. Regarding child-restraint systems which can be installed, refer to the accessories catalog.

X = ISOFIX position not suitable for ISOFIX child-restraint systems in this mass group and/or this size class.

i-Size child-restraint systems

Vehicles with the  mark indicated on the front surface of a rear seatback are i-Size child-restraint certified.

Marking location

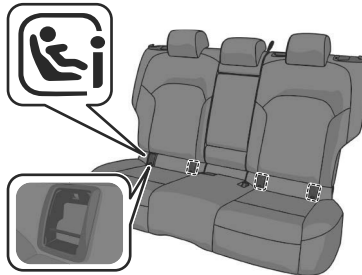

An i-Size child-restraint system can be installed to the specified seat as follows:

	Front passenger seat	Rear seat (outboard)	Rear seat (centre)
i-Size child-restraint systems	X	X	X

Key of letters to be inserted in the above table:

X = Seating position not suitable for i-Size “universal” child-restraint systems.

NOTE

Vehicles with the  mark indicated on the front surface of a rear seatback are not i-Size child-restraint certified.

Child-restraint Systems

Seat belt-secured child-restraint systems

System group	Age group	Weight group	Child-restraint system type	Front passenger seat	Rear seat (out-board)	Rear seat (centre)
GROUP 0	Up to about 9 months old	Up to 10 kg (up to 22 lb)	Baby seat	X	U	U
GROUP 0+	Up to about 2 years old	Up to 13 kg (up to 29 lb)	Baby seat	X	U	U
GROUP 1	About 8 months to 4 years old	9 kg— 18 kg (20 lb— 40 lb)	Child seat	X	U	U
GROUP 2	About 3 to 7 years old	15 kg— 25 kg (33 lb— 55 lb)	Junior seat	X	U	U
GROUP 3	About 6 to 12 years old	22 kg— 36 kg (48 lb— 79 lb)	Junior seat	X	U	U

Key of letters to be inserted in the above table:

U = Suitable for “universal” category restraints approved for use in all mass group.

UF = Suitable for forward-facing “universal” category restraints approved for use in all mass group.

X = Seat position not suitable for children in this mass group.

(Other countries)

- Regarding child-restraint systems which can be installed to your Mazda, consult an expert repairer (we recommend an Authorised Mazda Repairer).
- A child-restraint system with a support leg cannot be installed on the rear centre seat position.
- Please comply with the legal regulations concerning the use of child-restraint systems in your country.
- For the CRS which do not carry the ISO/XX size class identification (A to G), for the applicable mass group, the child seat manufacturer shall indicate the vehicle specific ISOFIX child-restraint systems recommended for each position.

How to Use the ISOFIX Anchor and Anchor Bracket

Anchor brackets for securing child-restraint systems are equipped in the vehicle. Locate each anchor position using the illustration. To install a child-restraint system, remove the head restraint. Always follow the instruction manual accompanying the child-restraint system

Anchor bracket location

Use the indicated anchor bracket locations when installing a child-restraint system equipped with a tether.

If the top tether strap does not reach the anchor bracket, purchase and use an extension strap provided by the CRS manufacture.

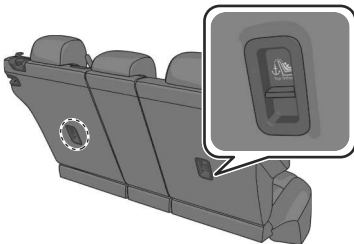

1. First, adjust the front seat to allow clearance between the child-restraint system and the front seat.
Refer to How to Use the Front Seats on page 3-25
If the rear seat is reclined, return it to the upright position.
2. Make sure the seatback is securely latched by pushing it back until it is fully locked.

3. Expand the area between the seat bottom and the seatback slightly to verify the locations of the ISOFIX anchors and remove the cover.

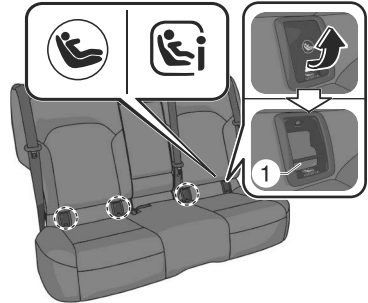

1. ISOFIX anchor

4. Remove the head restraint. However, when installing a booster seat, always install the vehicle head restraint to the seat where the booster seat is installed. Refer to Head Restraints on page 3-37.
5. Secure the child-restraint system using the ISOFIX anchor, following the child-restraint system manufacturer's instruction.

Child-restraint Systems

6. If your child-restraint system came equipped with a tether, that probably means it is very important to properly secure the tether for child safety. Please carefully follow the child-restraint system manufacturer's instructions when installing tethers.

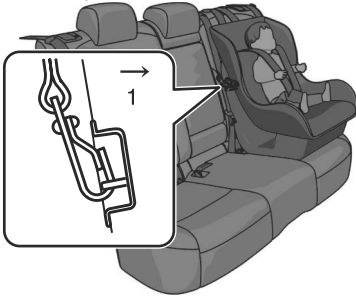

1. Forward

NOTE

- The ISOFIX anchors marking on the cover indicates the position of the ISOFIX anchors for the attachment of a child-restraint system.
- Store the removed cover so that it does not get lost.

4

Opening/closing

Key.....	4-4
Key.....	4-4
Warnings and Cautions for Using the Key.....	4-4
How to Use the Key.....	4-5
Convenient Ways to Use the Key.....	4-8

Advanced Keyless Entry

System.....	4-9
Advanced Keyless Entry System*.....	4-9
Warnings and Cautions for Using the Advanced Keyless Entry System.....	4-9
How to Use the Advanced Keyless Entry System.....	4-10

Doors.....	4-11
Warnings and Cautions for Using the Doors.....	4-11
How to Use the Doors.....	4-12
Convenient Ways to Use the Doors.....	4-16

Liftgate.....	4-17
Warnings and Cautions for Using the Liftgate.....	4-17
How to Use the Liftgate.....	4-18
Power Liftgate*.....	4-19
Warnings and Cautions for Using the Power Liftgate.....	4-19
How to Use the Power Liftgate.....	4-21

Convenient Ways to Use the Power Liftgate.....	4-25
--	------

Bonnet.....	4-26
Warnings and Cautions for Using the Bonnet.....	4-26
How to Use the Bonnet.....	4-27

Windows.....	4-28
Power Windows.....	4-28
Warnings and Cautions for Using the Power Windows.....	4-28
How to Use the Power Windows.....	4-29
Convenient Ways to Use the Power Windows.....	4-30

Panorama sunroof.....	4-31
Panorama sunroof*.....	4-31
Warnings and Cautions for Using the Panorama sunroof.....	4-31
How to Use the Panorama sunroof.....	4-32

Security System.....	4-34
Security System.....	4-34
Warnings and Cautions for Using the Security System.....	4-34
Immobilizer System.....	4-35
Warnings and Cautions for Using the Immobilizer System.....	4-35
How to Use the Immobilizer System.....	4-36
Theft-Deterrent System*.....	4-37

Warnings and Cautions for Using
the Theft-Deterrent System
..... 4-37

How to Use the Theft-Deterrent
System..... 4-38

MEMO

Key

All doors, fuel-filler flap, and the liftgate can be locked/unlocked by pressing the key switch. The key must be carried by the driver.

Key Code Number Plate

An auxiliary key can be ordered based on the key code number printed on the key code number plate at an expert repairer (we recommend an Authorised Mazda Repairer).

- Store the key code number plate in a safe place (not in the vehicle).
- Do not divulge the key number to others.



Warnings and Cautions for Using the Key

WARNING

Do not leave the key in your vehicle with children and keep them in a place where your children will not find or play with them.

Leaving children in a vehicle with the key is dangerous. This could result in someone being badly injured or even killed. Children may find these keys to be an interesting toy to play with and could cause the power windows or other controls to operate, or even make the vehicle move.

CAUTION

- Changes or modifications not expressly approved by the party responsible for compliance could void the user's authority to operate the equipment.
- Because the key (transmitter) uses low-intensity radio waves, it may not function correctly under the following conditions:
 - The key (transmitter) is carried with communication devices such as cellular phones.
 - The key (transmitter) contacts or is covered by a metal object.
 - The key (transmitter) is near electronic devices such as personal computers.
 - Non-Mazda genuine electronic equipment is installed in the vehicle.
 - There is equipment which discharges radio waves near the vehicle.

- The key (transmitter) may consume battery power excessively if it receives high-intensity radio waves. Do not place the key (transmitter) near electronic devices such as televisions or personal computers.
- To avoid damage to the key (transmitter), DO NOT:
 - Drop the key (transmitter).
 - Get the key (transmitter) wet.
 - Disassemble the key (transmitter).
 - Expose the key (transmitter) to high temperatures on places such as the instrument panel, under direct sunlight.
 - Expose the key (transmitter) to any kind of magnetic field.
 - Place heavy objects on the key (transmitter).
 - Put the key (transmitter) in an ultrasonic cleaner.
 - Put any magnetized objects close to the key (transmitter).

How to Use the Key

When pressing the button, the operation indicator light turns on.

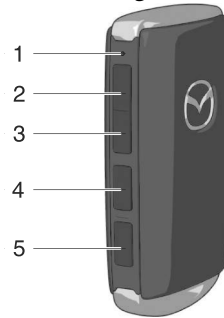

1. Operation indicator light
2. Lock button (🔒)
3. Unlock button (🔓)
4. Power liftgate button (🚗 or HOLD)*
5. Intrusion sensor cancel button (🚗 OFF)*

Lock button 🔒

Press the lock button with all of the following conditions met.

- The vehicle power is switched OFF.
- **(Except European models)**
All the doors are closed.

The doors, liftgate, fuel-filler flap are locked, the hazard warning lights operate 1 time.

(With the advanced keyless function (Except European models))

A beep sound will be heard once.

NOTE

- **(European models)**
When any door or the liftgate is open and the lock button is pressed, the closed doors can be locked. After that, any other open door or the liftgate can be locked by closing them.

- To prevent the transmitter from being left in the vehicle, make sure that the driver carries the transmitter when locking the doors with any door open.
- **(With theft-deterrent system)**
If the lock button is pressed with all the doors and liftgate closed, the hazard warning lights will flash and the theft-deterrent system is armed.

(Vehicles with double locking system)

How to Activate the system

Press the lock button, and then press the lock button again within 3 seconds.

The doors and liftgate cannot be opened from the inside the vehicle, and the hazard warning lights operate 1 time.

The indicator light  illuminates for about 3 seconds to indicate that the system has been activated.

How to Deactivate the System

Unlock the driver's door or start the engine.



Never activate the double locking system with passengers, especially children, still inside the vehicle:

Activating the system with passengers, especially children, still inside the vehicle is dangerous. The passengers cannot open the doors from inside. They would be trapped and subjected to extreme temperatures. This could result in serious injuries or even death.

Unlock button

Press the unlock button while the vehicle power is switched OFF.

(Without 2-step unlocking function)

The doors, liftgate, fuel-filler flap are unlocked, the hazard warning lights operate 2 times.

(With 2-step unlocking function)

The driver's door and the fuel-filler flap are unlocked, the hazard warning lights operate 2 times, and then a warning sound is activated 2 times.

Press the unlock button again within 5 seconds to unlock the other doors.

(With the advanced keyless function)

The hazard warning lights operate and a sound is activated 2 times at the same time. The initial setting is off depending on the market.

NOTE

- **(With the advanced keyless function)**

The sound can be switched on/off using the Mazda Connect.

Refer to Mazda Connect Owner's Manual or consult an expert repairer (we recommend an Authorised Mazda Repairer).

- **(With 2-step unlocking function)**

The 2-step unlocking function can be set to on/off using Mazda Connect.

Refer to Mazda Connect Owner's Manual or consult an expert repairer (we recommend an Authorised Mazda Repairer).

Liftgate open/close button or

Opening the liftgate

Press the liftgate open/close button on the key for about 1 second or longer when all of the following conditions are met.

- The vehicle power is switched OFF.

After the hazard warning lights flash 2 times is activated, the liftgate fully opens.

Closing the liftgate

Press the liftgate open/close button for about 1 second or longer when the vehicle power is switched OFF. After the hazard warning lights flash 2 times is activated, the liftgate fully closes.

NOTE

If the liftgate open/close button is pressed while the liftgate is opening/closing automatically, a warning sound is activated and the liftgate stops. When pressing the liftgate open/close button again, the liftgate moves in the reverse direction.

Intrusion sensor cancel button OFF*

Press the intrusion sensor cancel button within 20 seconds after pressing the LOCK button. The hazard warning lights flash 3 times and the intrusion sensor (part of the theft-prevention system) is deactivated. Switch the vehicle power from ON to OFF to reset.

Starting the engine

NOTE

- Starting the engine may be possible even if the key is outside of the vehicle and extremely close to a door and window, however, always start the engine from the driver's seat. If the vehicle is started and the key is not in the vehicle, the vehicle will not restart after it is shut off and the vehicle power is switched off.

- The luggage compartment is out of the assured operational range, however, if the key (transmitter) is operable the engine will start.

With the advanced keyless function

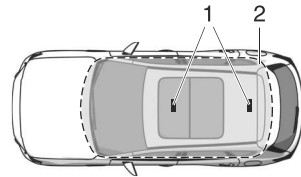

1. Interior aerial
2. Operational range

Without the advanced keyless function

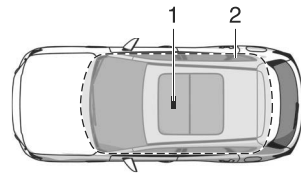

1. Interior aerial
2. Operational range

NOTE

The engine may not start if the key is placed in the following areas:

- Around the instrument panel
- In the storage compartments such as the glove compartment or the centre console

Convenient Ways to Use the Key

Sound function

The function that the sound notifies you of unlocking/locking can be turned on or off by changing the setting in Mazda Connect. The volume of the warning sound can also be changed.

Auto re-lock function

All doors, the liftgate, and the fuel flap are locked automatically if any of the following operations are not performed within about 30 seconds after they are unlocked by pressing the unlock button.

- Open any door or liftgate.
- The vehicle power is switched to any position other than off.

NOTE

The time until the door is automatically locked can be changed.

Refer to the Settings section in the Mazda Connect Owner's Manual.

Power Saving Function

By turning on the power saving function of the key, the advanced keyless entry and the function to start the engine without removing the key from a pocket or purse/case are turned off, and the battery power consumption of the key can be reduced.

The remote control function is still operational by pressing a button on the key even while the power saving function is turned on. However, the remote operation indicator light does not turn on or flash.

Turning on the power saving function

1. Press the lock button on the key 4 times within 3 seconds.
The key operation indicator light turns on.
2. Press the lock button for 2 seconds or longer while the key operation indicator light is turned on.
The hazard warning lights and a warning sound operate 1 time, and the power saving function is turned on.

Turning off the power saving function

1. Press the lock button on the key 4 times within 3 seconds.
The key operation indicator light turns on.
2. Press the lock button for 2 seconds or longer while the key operation indicator light is turned on.
The hazard warning lights and a warning sound operate 1 time, and the power saving function is turned off.

Advanced Keyless Entry System*

The advanced keyless function allows you to lock/unlock the doors, liftgate, and fuel-filler flap, open the liftgate, and starting the engine while carrying the key.

Warnings and Cautions for Using the Advanced Keyless Entry System

WARNING

Radio waves from the key may affect medical devices such as pacemakers. Before using the key near people who use medical devices, ask the medical device manufacturer or your physician if radio waves from the key will affect the device.

How to Use the Advanced Keyless Entry System

The system operates only when the driver is in the vehicle or within operational range while the key is being carried.

NOTE

- The advanced keyless entry system functions can be deactivated to prevent any possible adverse effect on a user wearing a pacemaker or other medical device. If the system is deactivated, you will be unable to start the engine by carrying the key. Consult an expert repairer (we recommend an Authorised Mazda Repairer) for details. If the advanced keyless entry system has been deactivated, you can start the engine by following the procedure indicated when the key battery goes dead. Refer to Starting the engine with a dead key battery on page 8-9.
- The advanced keyless entry system does not operate while the power saving function is operating.
- When the battery power is low, or in places where there are high-intensity radio waves or noise, the operational range may become narrower or the system may not operate.

Locking/Unlocking Using Touch Sensor

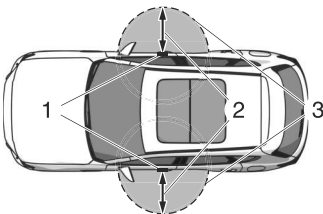

1. Exterior aerial
2. 80 cm (31 in)
3. Operational range

NOTE

- The system may not operate if you are too close to the windows or door handles, or liftgate.
- If the key is left in the following areas and you leave the vehicle, the doors may be locked depending on the radio wave conditions even if the key is left in the vehicle.
 - Around the instrument panel
 - In the storage compartments such as the glove compartment or the centre console
 - Next to a communication device such as a mobile phone

Locking Using Door-Lock Switch/ Unlocking Using Electric Liftgate Opener

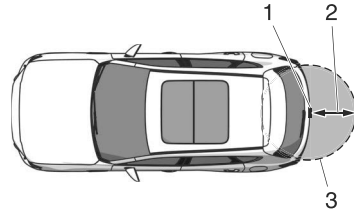

1. Exterior aerial
2. 80 cm (31 in)
3. Operational range

Warnings and Cautions for Using the Doors

WARNING

Opening/closing of the doors must be done by an adult.

If a person's hand, foot, or neck is pinched in a door, it could result in serious injury.

Do not drive the vehicle with the door-ajar warning light/indication turned on/displayed.

Otherwise, the door may open unexpectedly and result in an accident.

Always take all children and pets with you or leave a responsible person with them.

Leaving a child or a pet unattended in a parked vehicle is dangerous. In hot weather, temperatures inside a vehicle can become high enough to cause brain damage or even death.

Do not leave the key in your vehicle with children and keep them in a place where your children will not find or play with them.

Leaving children in a vehicle with the key is dangerous. This could result in someone being badly injured or even killed.

Keep all doors locked when driving. Unlocked doors in a moving vehicle are dangerous. Passengers can fall out if a door is accidentally opened and can more easily be thrown out in an accident.

Always close all the windows and Panorama sunroof, lock the doors, fuel-filler flap, and liftgate and take the key with you when leaving your vehicle unattended.

Leaving your vehicle unlocked is dangerous as children could lock themselves in a hot vehicle, which could result in death. Also, a vehicle left unlocked becomes an easy target for thieves and intruders.

After closing the doors and the liftgate, always verify that they are securely closed.

Doors and the liftgate not securely closed are dangerous, if the vehicle is driven with a door and the liftgate not securely closed, the door and the liftgate could open unexpectedly resulting in an accident.

Always confirm the safety around the vehicle before opening a door and the liftgate.

Suddenly opening a door and the liftgate is dangerous. A passing vehicle or a pedestrian could be hit and cause an accident.

CAUTION

Always confirm the conditions around the vehicle during strong winds or when parked on an incline before opening/closing the doors. Neglecting to check the conditions around the vehicle could result in fingers getting caught in the door or a passing pedestrian being hit, resulting in an unexpected accident or injury.

How to Use the Doors

To prevent the key from being left in the vehicle, make sure that you carry the key before locking.

Locking/Unlocking Using the Key

Refer to How to Use the Key on page 4-5.

Locking/Unlocking Using the Touch Sensor (Vehicles with Advanced Keyless Function)

Locking

Touch the sensing area of the door lock touch sensor when all of the following conditions are met.

- The vehicle power is switched OFF.
- All the doors are closed.
- The key is on the sensing area of the touch sensor.

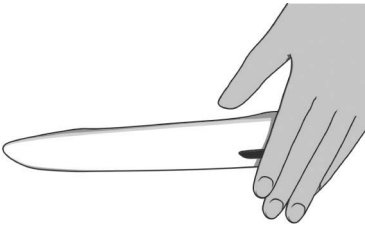

The hazard warning lights operate once, and all the doors, liftgate, fuel-filler flap are locked.

(Except European models)

A beep sound operates one time.

Unlocking

When all of the following conditions are met, touch the sensing area of the door release touch sensor.

- The vehicle power is switched OFF.
- The driver's door is locked.
- Three seconds or longer have passed since the doors were locked.

- The key is on the sensing area of the touch sensor.

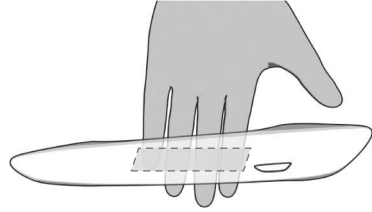

Type A

(Unlocking from the driver's door)

The following locations are unlocked by touching the sensing area of the door release touch sensor of the driver's door.

- Driver's door
- Fuel-filler flap

When unlocking, the hazard warning lights operate two times.

(Except European models)

A beep sound operates two times.

(Unlocking from the front passenger's door)

The following locations are unlocked by touching the sensing area of the door release touch sensor of the front passenger's door.

- All doors
- Fuel-filler flap
- Liftgate

When unlocking, the hazard warning lights operate two times.

(Except European models)

A beep sound operates two times.

Type B

The following locations are unlocked by touching the sensing area of the door release touch sensor.

- All doors
- Fuel-filler flap

- Liftgate

When unlocking, the hazard warning lights operate two times.

(Except European models)

A beep sound operates two times.

NOTE

- **(With 2-step unlocking function)**
The location to be unlocked can be changed.
Refer to Mazda Connect Owner's Manual or consult an expert repairer (we recommend an Authorised Mazda Repairer).
- The beep sound can be turned on/off using Mazda Connect.
Refer to Mazda Connect Owner's Manual or consult an expert repairer (we recommend an Authorised Mazda Repairer).
- The system may not operate normally under the following conditions.
 - You touch the sensing area of the door lock touch sensor and the sensing area of the door release touch sensor at the same time.



- You touch the sensing area of the touch sensor while wearing gloves.
- Foreign matter such as water, ice, snow, or dirt is on the detection area of the touch sensor.

- The system may operate if the outer side door handle of a front door is splashed with water by a car wash or rain while the key is in the operation range.

Locking/Unlocking Using the Door-Lock Switch

The following locations are locked/unlocked.

- All doors
- Liftgate
- Fuel-filler flap

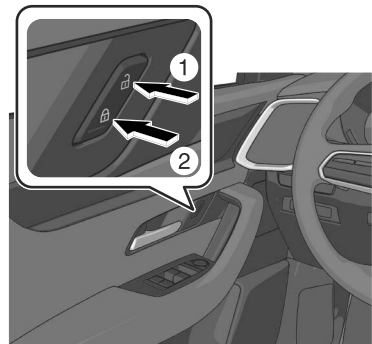

1. Unlocking
2. Locking

Locking the doors from the outside using the door-lock switch (European models)

Doors can be locked from the outside of the vehicle without using the transmitter.

You can lock the doors by pressing the lock side of the door-lock switch with all of the following conditions met, and then closing all the doors.

- The vehicle power is switched OFF.
- Any door is open.
- The key is not in the vehicle.

Doors

After locking by pressing the door-lock switch, closing all the doors with the transmitter left in the vehicle unlocks all doors, the liftgate, and the fuel-filler flap.

Door-lock switch on liftgate (With the advanced keyless function)

With power liftgate

Refer to How to Use the Power Liftgate on page 4-21.

Without power liftgate

When all of the following conditions are met, press the door-lock switch and then close the liftgate.

- You are carrying the transmitter.
- The vehicle power is switched OFF.
- All the doors are closed.

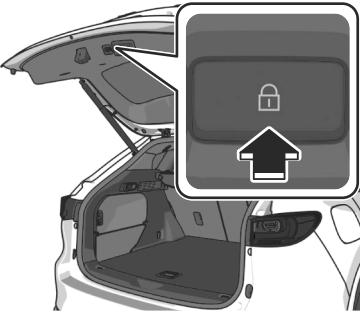

All the doors, liftgate, fuel-filler flap, and the fuel-filler flap are locked.

(With theft-deterrent system (European models))

When the liftgate closes, the hazard warning lights operate 1 time.

(With theft-deterrent system (Except European models))

When locking, a beep sound operates 1 time.

When the liftgate closes, the hazard warning lights operate 1 time.

(Without theft-deterrent system (European models))

When locking, the hazard warning lights operate 1 time.

(Without theft-deterrent system (Except European models))

When locking, the hazard warning lights and a beep sound operate 1 time.

NOTE

- To prevent the transmitter from being left in the vehicle, make sure that the driver carries the transmitter when locking the doors with any door open.
- After locking by pressing the door-lock switch and if the liftgate is closed last with the transmitter in the vehicle, the liftgate will not be locked.

Locking/Unlocking Using the Door-Lock Knob

Locking/unlocking only the door where the door-lock knob is operated.

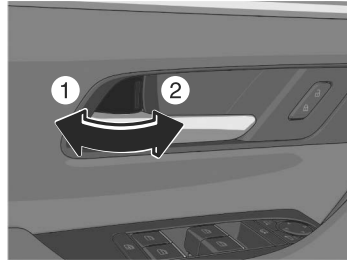

1. Unlocking
2. Locking

Locking the doors from the outside using the door-lock knob

A door can be locked by turning the inside lock knob to the lock side and closing the door.

NOTE

- After locking by pressing the door-lock switch, if the liftgate is closed last with the transmitter left in the vehicle, the liftgate will not be locked.
- In the following cases, the doors are unlocked to prevent the key from being left in the vehicle.
 - When the vehicle power is switched to ACC or ON, and the lock knob on the driver's door is turned to the lock side while either a door or the liftgate is open.
 - The key is left in the vehicle.

Locking Using the Vehicle Speed Sensing Auto Door Lock Function

- All the doors, the liftgate, the fuel-filler flap are locked when the vehicle speed exceeds 20 km/h (12 mph).
- All the doors, the fuel flap, and the liftgate are unlocked when the vehicle power is switched OFF.

Refer to Mazda Connect Owner's Manual or consult an expert repairer (we recommend an Authorised Mazda Repairer).

Using the Child Safety Lock

This will prevent the doors from being opened by a child while seated in the rear seat.

1. Open the rear door.
2. Remove the auxiliary key.
3. Turn the child safety lock to the lock side.

When the rear door is closed, it cannot be opened using the interior door handle.

When not using the child safety lock, turn the child safety lock to the unlock side.

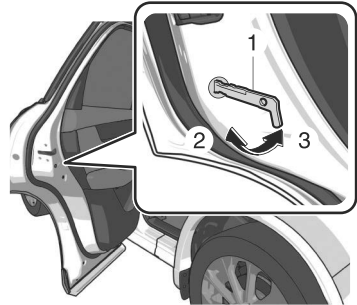

1. Auxiliary key
2. Locking
3. Unlocking

Impact detection door-lock unlock system

This system automatically unlocks all the doors and the liftgate (vehicles without power liftgate) if the vehicle receives a strong impact such as from an accident. By unlocking automatically, occupants can be rescued from outside the vehicle. If the vehicle receives a strong impact while the vehicle power is switched ON, all the doors and the liftgate (vehicles without power liftgate) will be unlocked automatically after about 6 seconds.

The doors and liftgate may not unlock depending on how an impact is applied, the force of the impact, and other conditions of the accident.

Convenient Ways to Use the Doors

Proximity Type Auto Lock Function

You can set the vehicle to lock automatically when you leave the detection area of the touch sensor. Refer to Mazda Connect Owner's Manual or consult an expert repairer (we recommend an Authorised Mazda Repairer).

A sound is activated one time when closing all the doors and the liftgate while the key is being carried.

If you proceed to leave the operation range, the vehicle is locked automatically (it is locked automatically after about 30 seconds even if you do not leave the operation range).

NOTE

However, they are not locked under the following conditions.

- Another key is left inside the vehicle.
- The driver's door is already locked.

Auto re-lock function

The vehicle is locked automatically by the auto re-lock function if you do not perform any of the following operations within about 30 seconds after touching the detection area of the touch sensor or unlocking with the key.

- Open any door or liftgate.
- Switch the vehicle power to a position other than OFF.

The time required until automatic locking occurs can be changed. Refer to Mazda Connect Owner's Manual or consult an expert repairer (we recommend an Authorised Mazda Repairer).

Warnings and Cautions for Using the Liftgate

WARNING

Do not allow people to ride in the luggage compartment.

During sudden braking or a collision, the person in the luggage compartment could be seriously injured or killed.

Always drive the vehicle with the liftgate closed.

If the liftgate opens while driving the vehicle, the luggage may fall out and lead to an accident. In addition, if the vehicle is driven with the liftgate open, the exhaust gas may penetrate the cabin and it could cause carbon monoxide poisoning.

Do not stack or leave loaded luggage unsecured in the luggage compartment.

Otherwise, the luggage may move or collapse, resulting in injury or an accident. In addition, do not load luggage higher than the seatbacks. It may affect the side or rear field of view. If the air bags deploy, the cargo may scatter which could result in serious injury or death.

After closing the liftgate, make sure that it is securely closed.

Driving the vehicle with the liftgate not fully closed is dangerous as a person or an object could fall out of the vehicle resulting in a serious accident, injury, or death.

Do not drive the vehicle with the liftgate-ajar warning indication displayed.

Otherwise, the liftgate may open unexpectedly and result in an accident.

CAUTION

- Remove snow or ice on the liftgate before opening the liftgate. When opening the liftgate, it could slam shut by the weight of snow or ice, resulting in injury.
- Be careful when opening/closing the liftgate during strong winds. Otherwise, it could close suddenly resulting in injury.
- When opening the liftgate, fully open it and make sure that it stays open. If the liftgate is only opened partially, it could slam shut by vibration or wind gusts resulting in injury.
- Stop the engine when loading or unloading cargo in the luggage compartment. Otherwise, you could get burned by the heat of the exhaust gas.
- Be careful not to apply excessive force to the damper stay on the liftgate such as by putting your hand on the stay. Otherwise, the damper stay may bend and affect the liftgate operation.

- Be careful not to pinch your hand when closing the liftgate. It may result in an injury if your hand is caught.

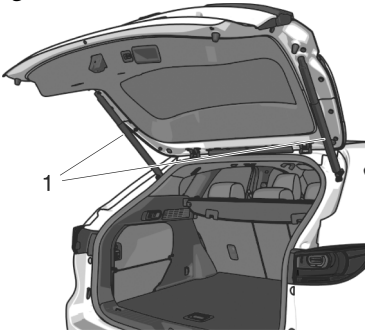

1. Damper stay

- Do not modify or replace the liftgate damper stay. Consult an Authorised Mazda Dealer if a liftgate damper stay is deformed or damaged for reasons such as a collision or if there is some other problem.

How to Use the Liftgate

Opening the Liftgate

1. Unlock the door.
2. Press the electric liftgate opener.

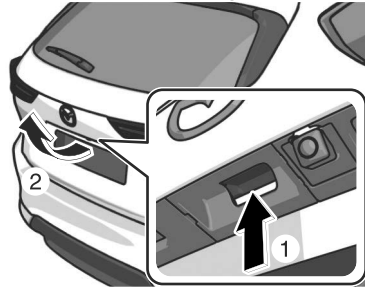

3. Lift the liftgate.

NOTE
(Vehicles with advanced keyless function)

The liftgate can be opened even while the doors and the liftgate are locked by pressing the electric liftgate opener while carrying the key.

Closing the Liftgate

1. Lower the liftgate slowly using the liftgate recess.
2. Press down the liftgate to close.

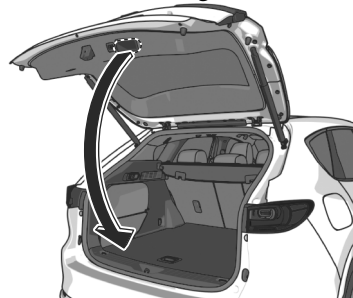

Power Liftgate*

The liftgate opens and closes automatically by operating the key switch or various switches for the vehicle.

The power liftgate has 3 functions.

Hands-free function*

The liftgate can be opened and closed by doing a kicking motion when both hands are occupied, such as when holding groceries or luggage.

Liftgate easy closure

The easy closure assists in closing the liftgate.

When you close the liftgate to the position where it is slightly ajar, it will finish closing automatically to the fully-closed position.

NOTE

If the liftgate is opened/closed repeatedly in a short period of time, the easy closure function may not operate. Wait for about 2 seconds and then try again.

Jam-safe function

The jam-safe function detects a person or obstruction to prevent the person or object from getting caught in the liftgate.

When the jam-safe function detects that a person or object is caught in the liftgate while it is opening/closing automatically, a warning sound is activated and the liftgate moves in the reverse direction, and then stops.

NOTE

The jam-safe function does not operate while the easy closure is operating (from ajar position to fully closed position).

Warnings and Cautions for Using the Power Liftgate

WARNING

Always check the safety of the area around the liftgate before operating/closing it automatically.

Not checking the safety of the area around the liftgate for people before opening/closing the liftgate automatically is dangerous. A person could become caught between the liftgate and an obstruction while it is opening automatically or between the liftgate and vehicle while it is closing automatically, resulting in an accident and serious injury.

Keep your eyes on the liftgate when opening/closing the liftgate automatically.

If there is an obstruction, the liftgate may not fully close due to the jam-safe function. Driving the vehicle with the liftgate not fully closed is dangerous as a person or an object could fall out of the vehicle resulting in a serious accident, injury, or death.

Do not let a child operate the switches.

If the liftgate is opened/closed unexpectedly by a child operating the switches mistakenly, the child or another occupant's head or hands could get caught, resulting in an accident and serious injury.

Always make sure that there is no person or obstruction around the liftgate before closing the liftgate. The jam-safe function detects a person or obstruction to prevent the person or object from getting caught. The system may not detect certain objects obstructing the liftgate depending on the way they are positioned and their shape. Be especially careful with children. It may result in an injury if a finger gets pinched.

⚠ CAUTION

- When closing the liftgate, make sure that there is no foreign matter around the striker. If foreign matter is obstructing the striker, the liftgate may not close properly.

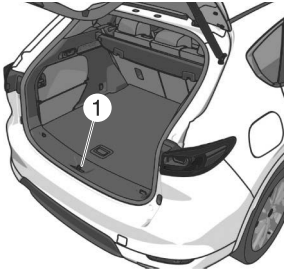

1. Striker

- Do not install accessories to the liftgate other than those specified. Otherwise, the liftgate may not open/close automatically resulting in a malfunction.
- When the liftgate is switched from automatic to manual operation, the liftgate may open/close unexpectedly depending on its position, resulting in injury.

- Be careful that your fingers do not get pinched in a closing liftgate. The liftgate finishes closing to the fully-closed position automatically after you close it to where it is slightly ajar. If your fingers get pinched, it may result in an injury.
- Do not apply excessive force to the liftgate when closing it. Otherwise, it could cause a system malfunction.
- Sensors are installed on both ends of the liftgate. Be careful not to allow the sensors to be scratched or damaged by sharp objects. Otherwise, the liftgate may no longer open/close automatically. In addition, if the sensor is damaged while the liftgate is closing automatically, the liftgate stops.

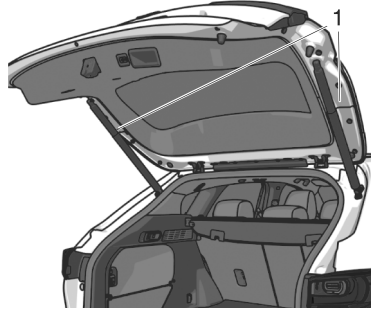

1. Sensor

- Do not paint the rear bumper or install any add-on equipment to it. Otherwise, the hands-free sensor may not operate normally.
- If you are carrying the key around the liftgate or there is another person around the liftgate who is carrying a key, do not allow the following to occur. Otherwise, the hands-free sensor will operate and the liftgate may open/close unexpectedly resulting in an accident.

To prevent an unintended operation, place the key outside of its operation range or turn off the hands-free function using Mazda Connect.

- A person not carrying a key does the kicking motion.
- While the liftgate is open, a person sitting on the edge of the luggage compartment swings his or her legs.
- Installing/removing the body cover or removing snow around the rear bumper.
- Picking up something which was dropped under the rear bumper.
- Spraying water on the rear bumper using a high water pressure car washer.
- Pushing a shopping cart close to the rear bumper.
- A moving object such as an animal or a ball approaches the rear bumper.

How to Use the Power Liftgate

NOTE

- In the following cases, the liftgate may not open/close automatically.
 - The vehicle is parked on an incline.
 - There are strong winds.
 - There is snow on the liftgate.
- If the lead-acid battery is disconnected with the liftgate open, the liftgate cannot be opened/closed automatically. To restore the automatic open/close function, fully close the liftgate manually.
- If the system detects weight such as that caused by a snow-laden liftgate when it is opened automatically, a warning sound is activated, the liftgate moves in the reverse direction, and then stops.
- If the selector lever is shifted to another position and the vehicle is moved while the liftgate is opening/closing automatically, a warning sound is activated and the liftgate closes.
- The liftgate may close unexpectedly after opening it on slopes. Always make sure that the liftgate is stationary.

When the following operations are performed, the hazard warning lights flash 2 times, a warning sound is activated, and the liftgate automatically opens/closes fully.

Opening/closing using the liftgate open/close switch (or) on the key

Press the liftgate open/close switch on the key for 1 second or longer when all of the following conditions are met.

- The vehicle power is switched OFF.
- The vehicle is stopped.

Opening/closing the liftgate using the power liftgate switch

Press the power liftgate switch for 1 second or longer when all of the following conditions are met.

- The vehicle is stopped.
- The vehicle power is switched to a position other than ON, or the selector lever is in the P position with the vehicle power switched ON
- All the doors are unlocked (when opening)

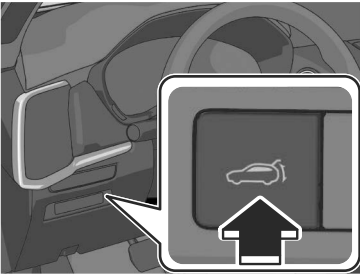

Opening the liftgate using the electric liftgate opener

Press the electric liftgate opener when all of the following conditions are met.

- The vehicle power is switched to a position other than ON, or the selector lever is in the P position with the vehicle power switched ON
- All the doors are unlocked.

NOTE

The liftgate can be opened even while the doors are locked by pressing the electric liftgate opener while carrying the key.

Closing the liftgate using the power liftgate close switch

Press the power liftgate close switch when all of the following conditions are met.

- The vehicle power is switched to a position other than ON, or the selector lever is in the P position with the vehicle power switched ON

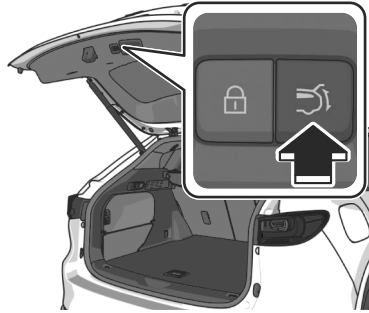

Closing using the door-lock switch on the liftgate*

Press the door-lock switch on the liftgate when all of the following conditions are met.

- You are carrying the key.
- The vehicle power is switched OFF.
- All the doors are closed.
- The liftgate is not automatically opening/closing.

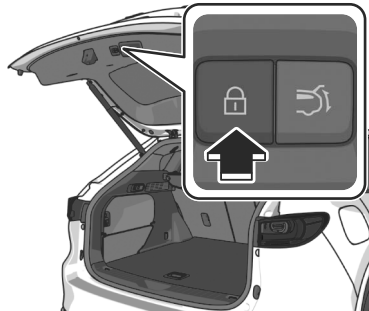

The doors, liftgate, and the fuel-filler flap are locked, the hazard warning lights operate 1 time. Then, the liftgate fully closes automatically.

Opening/closing using the hands-free function

Do the kicking motion with all of the following conditions met while the vehicle is stopped.

- You are carrying the key.
- The hands-free function is on.
- The vehicle power is switched to a position other than ON, or the selector lever is in P with the vehicle power switched ON.



A : About 30—50 cm (12—19.7 in)
B : About 10 cm (3.9 in)

When the kicking motion is done correctly, the hazard warning lights flash 2 times, a beep sound is activated, and the liftgate opens/closes automatically. Be careful not to contact the liftgate.

Move your foot away from under the bumper within about 1 second after moving it under the bumper. If the kicking motion is done while the liftgate is opening/closing automatically, the liftgate will stop. If the kicking motion is done again, the

liftgate moves in the direction opposite to the direction it was moving before it stopped.

CAUTION

- Do not do the kicking motion while wearing footwear which exposes the feet, such as sandals. If your foot contacts the hot exhaust pipe, it could cause serious burns.
- Do not do the kicking motion while the area where you are standing is unstable such as a slope or icy road. Otherwise, you could fall down, resulting in injury.

NOTE

- The hands-free sensor detects in a range of about 30 cm on both the left and right sides from the centre of the rear bumper.

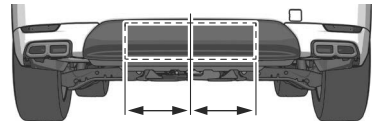

- The hands-free sensor may not operate normally under the following conditions.
 - Your foot remains placed within the detection area.
 - You move your foot left and right within the detection area.
 - The kicking motion is too fast or too slow.
 - Your foot contacts the rear bumper when doing the kicking motion.
 - You are wearing shoes such as rubber boots which do not conduct electricity well.
 - There is equipment emitting strong radio waves near the vehicle.
 - The detection area of the hands-free sensor is dirty.

- When the detection area of the hands-free sensor is dirty, wipe it off with a clean cloth. Before cleaning the sensor, place the key outside of its operation range or turn off the hands-free function using Mazda Connect.
- If the operation using the hands-free sensor is not possible even though the operation conditions are met, consult an Authorised Mazda Dealer.

Hands-free function ON/OFF switching

The hands-free function can be switched on/off.

Refer to Mazda Connect Owner's Manual or consult an expert repairer (we recommend an Authorised Mazda Repairer).

To prevent an unintended operation, turn off the function.

Stopping the liftgate

If any of the following operations is done, the automatic opening and closing of the liftgate stops.

- The liftgate open/close switch on the key is pressed.
- The power liftgate switch is pressed.
- The electric liftgate opener is pressed.
- The power liftgate close switch is pressed.
- The door-lock switch on the liftgate is pressed.
- The kicking motion is done.

NOTE

The liftgate cannot be stopped when it is half open or lower. It moves in the close direction by the load weight of the liftgate itself.

The automatic opening/closing of the liftgate can be stopped using the kicking motion even if you do not have the key.

Moving the liftgate again

If any of the following operations is done, the liftgate moves in the direction opposite to the direction it was moving before it stopped.

- The liftgate open/close switch on the key is pressed for 1 second or longer.
- The power liftgate switch is pressed for about 1 second or longer.
- The electric liftgate opener is pressed.
- The power liftgate close switch is pressed.

When the door-lock switch on the liftgate is pressed, the liftgate automatically fully closes.

Convenient Ways to Use the Power Liftgate

The liftgate fully-open position can be changed according to the height of a garage.

Set the desired fully-open position of the liftgate at the position where it is open more than halfway. The liftgate fully-open position cannot be changed to a position that is less than half open.

Changing the fully-open position

1. Stop the liftgate at the desired position.
2. Press and hold the power liftgate close switch for 3 seconds or longer.

A warning sound is activated 2 times to indicate that the position change has been completed.

Resetting the set fully-open position

1. Open the liftgate.
2. Press and hold the power liftgate close switch for 7 seconds or longer.
A warning sound is activated 3 times to indicate that the reset has been completed.

NOTE

After 3 seconds have passed since the switch was pressed, a warning sound is activated 2 times to indicate that the liftgate fully-open position has changed. Continuously press the switch for 7 seconds to complete the reset.

Warnings and Cautions for Using the Bonnet

WARNING

Do not drive the vehicle with the door-ajar warning indication displayed.

If the bonnet opens while driving the vehicle, it will obstruct the front view and could cause an accident.

CAUTION

- Do not close the bonnet or open the bonnet to the fully-opened position with the engine cover open. The engine cover may be damaged resulting in injury.
For details on opening and closing the engine cover.
Refer to Checking the Inspection Locations and Inspection Items on page 9-27.
- When closing the bonnet, do not push it excessively such as by applying your weight. Otherwise, the bonnet could be deformed.
- Be careful not to pinch your hand when closing the bonnet. It may result in an injury if your hand is caught.
- When inspecting the engine compartment, do not misplace any tools or cloth. Misplacing any tools or cloth may result in engine damage, cause a fire, or cause an unexpected accident.
- Be careful not to apply excessive force to the damper stay on the bonnet such as by putting your hand on the stay. Otherwise, the damper stay may bend and affect the bonnet operation.

- Do not modify or replace the bonnet damper stay. Consult an Authorised Mazda Dealer if you find a problem.
- When opening the bonnet, make sure that the bonnet stops. If the bonnet is only opened partially, it could slam shut by vibration or wind gusts resulting in injury.

How to Use the Bonnet

Opening the Bonnet

1. Pull the bonnet release handle.
The bonnet will raise slightly.

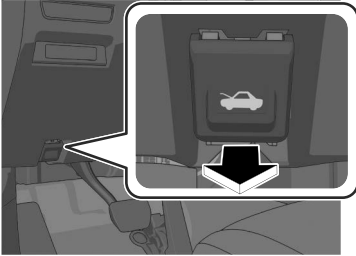

2. When the bonnet is raised by about 40 cm, it opens automatically.
When the bonnet is opened to a certain position, it is held open.

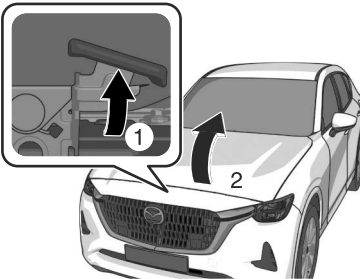

NOTE

If you push up from the position where the bonnet has stopped, you can open the bonnet further.

Closing the Bonnet

1. Make sure that there are no tools left in the engine compartment.
2. Lower the bonnet slowly and release it from a height of about 35 cm without applying excessive force.
The bonnet closes.

NOTE

When the bonnet is closed by pushing it with a hand, it may not be locked normally. If the bonnet does not close completely, open it again and operate it slightly more strongly using the same method.

Power Windows

The power window has two functions.

Auto-opening/Closing Function

The windows can be fully opened and closed without having to continue operating the power window switch.

Jam-Safe Function

If a foreign object is detected between the window and the window frame while the window is closing, the window stops closing and opens slightly.

NOTE

- The power windows cannot be opened from the outside of the vehicle if the power window initialization has not been completed.
Refer to Initializing the Power Window on page 8-34.
- **(A window cannot be closed)**
If the jam-safe function has operated and the window cannot be closed, check around the window frame for a foreign object.
If there is no foreign object around the window frame, forcibly close a window using the following procedure.
 1. After switching the vehicle power OFF, wait for 45 seconds or longer.
 2. Switch the vehicle power ON.
 3. Operate the switch in the direction to close the window until the jam-safe function operates and the window stops. Repeat this operation a total of 5 times.
 4. Continue pulling up the switch to fully close the window.

Warnings and Cautions for Using the Power Windows

WARNING

When closing the windows, be careful that a passenger's hand or head does not get pinched.

Be especially careful with children. If a hand or head becomes pinched, it could cause serious injury.

Do not let a child operate the power window switches.

If a hand or head becomes pinched, it could cause serious injury.

Keep the power window lock switch in the lock position when carrying a child.

If the child operates the power window switch incorrectly and a hand or head becomes pinched, it could cause serious injury.

Make sure that there is nothing blocking the window just before it closes completely or while the power window switch is being pulled.

The jam-safe function may not be able to prevent the window from closing completely. If a finger gets pinched, it could cause serious injury.

Do not let a child put a hand or head out of the window.

Be careful not to let a child put a hand or head out of the window while driving the vehicle. If the child's hand or head hits something outside the vehicle or sudden braking is applied, it could result in serious injury or death.

How to Use the Power Windows

Opening/Closing the Windows

1. Switch the vehicle power ON.
2. Operate the power window switch.
To fully open the window automatically, press the power window switch all the way down and then release it.
To fully close the window automatically, pull the power window switch all the way up and then release it.

Driver's Seat

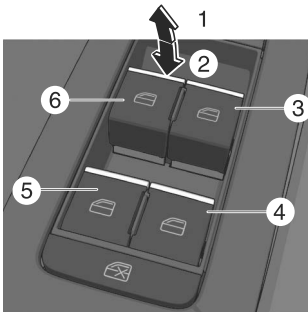

Front passenger/rear passenger seat

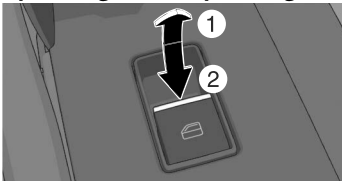

1. Close
2. Open
3. Front passenger's window
4. Right rear window
5. Left rear window
6. Driver's window

Locking the Front Passenger/Rear Seat Windows

Switch the power window lock switch on the driver's door to the lock position.

The driver's switch can be operated, however, the front passenger/rear passenger switches are no longer operable.

Press the power window lock switch again to the unlock position to cancel it.

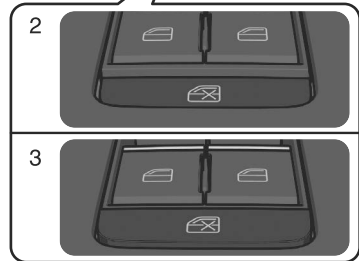
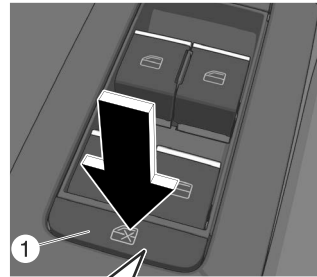

1. Power window lock switch
2. Lock position
3. Unlock position

Convenient Ways to Use the Power Windows

Operation Function After Vehicle power is Switched OFF

All the windows can be opened and closed for approximately 40 seconds after the vehicle power is switched to ACC or OFF with all doors closed. If any door is opened, the power window will stop operating.

Panorama sunroof*

The panorama sunroof can be opened or closed when operating the overhead tilt/slide switch at the front seats.

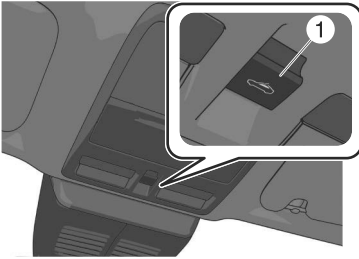

1. Tilt/slide switch

Jam-safe function

If foreign matter caught between the panorama sunroof and the window frame is detected while it is closing automatically, the panorama sunroof stops and opens partway.

NOTE

When the jam-safe function is inoperable, the panorama sunroof initial setting is not performed. Refer to Initializing the Panorama Sunroof on page 8-35.

Warnings and Cautions for Using the Panorama sunroof

! WARNING

When closing the panorama sunroof, be careful that a passenger's hand or head does not get pinched.

If a hand or head becomes pinched, it could cause serious injury.

Do not let a child operate the tilt/slide switch.

If a hand or head becomes pinched, it could cause serious injury.

Do not allow a passenger to put a hand or head out of the area where the panorama sunroof opens while driving the vehicle.

If the person's hand or head hits something outside the vehicle, or sudden braking is applied, it could result in serious injury or death.

While driving, do not let occupants stand up and extend a part of their body out of the opening.

Extending your head, arms, or other parts of your body from the panorama sunroof is dangerous. Your head or arm may hit something while driving, which could result in a fatal injury.

Just before the panorama sunroof completely closes, make sure there is nothing obstructing the panorama sunroof.

The jam-safe function may not prevent the panorama sunroof from closing completely. Getting your fingers pinched could cause serious injury.

CAUTION

- Do not sit on or put heavy items on the area where the panorama sunroof opens and closes. Otherwise, the panorama sunroof could be damaged.
- Do not open or close the panorama sunroof forcefully during freezing temperatures or snowfall. Otherwise, it could cause a malfunction.
- The sunshade does not tilt. To avoid damaging the sunshade, do not push it up.
- Do not close the sunshade while the panorama sunroof is opening. Trying to force the sunshade closed could damage it.

How to Use the Panorama sunroof

Operating the Sunshade

The sunshade can be opened or closed electrically only.

1. Switch the vehicle power ON.
2. Press the tilt/slide switch rearward.
The sunshade opens.

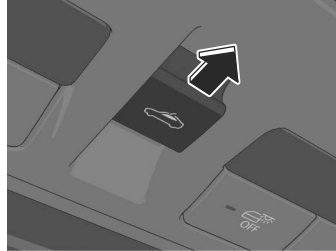

3. Press the tilt/slide switch forward.
The sunshade closes.

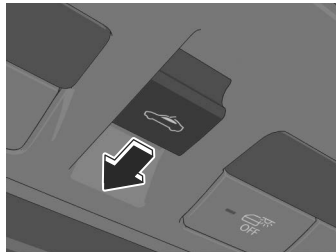

To stop it partway, operate the switch in the direction opposite to the direction it is opening/closing.

Tilt Operation

The panorama sunroof can be opened or closed electrically only.

1. Press the tilt/slide switch.
The rear side of the front glass panel of the panorama sunroof opens upwards.

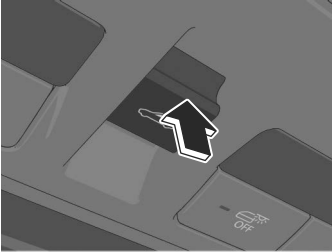

2. Press the tilt/slide switch forward 2 times.
The sunshade and the panorama sunroof close.

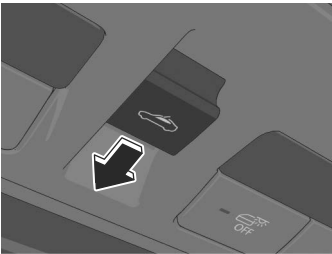

To stop it partway, operate the switch in the direction opposite to the direction it is opening/closing.

Slide Operation

1. Open the sunshade.
2. Press the tilt/slide switch rearward.
The panorama sunroof opens.

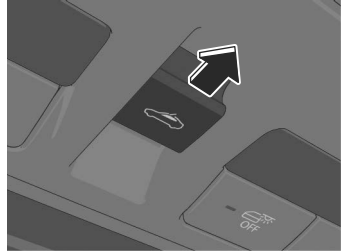

3. Press the tilt/slide switch forward.
The panorama sunroof closes.

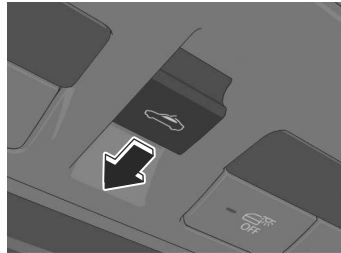

To stop it partway, operate the switch in the direction opposite to the direction it is opening/closing.

Security System

Mazda cannot guarantee the immobilizer and the theft-deterrent system's operation if the system has been modified or if any add-on equipment has been installed.

Warnings and Cautions for Using the Security System

 **CAUTION**

To avoid damage to the vehicle, do not modify the system or install any add-on equipment to the immobilizer and the theft-deterrent systems or the vehicle.

Immobilizer System

The immobilizer system allows the engine to start only with a key the system recognises.

NOTE

- The keys carry a unique electronic code. For this reason, and to assure your safety, obtaining a replacement key requires security validation, this will add some delays in supplying a replacement key. They are only available through an expert repairer (we recommend an Authorised Mazda Repairer).
- Always keep a spare key in case one is lost. If a key is lost, consult an expert repairer (we recommend an Authorised Mazda Repairer) as soon as possible.
- If you lose a key, an expert repairer (we recommend an Authorised Mazda Repairer) will reset the electronic codes of your remaining keys and immobilizer system. Bring all the remaining keys to an expert repairer (we recommend an Authorised Mazda Repairer) to reset.

Warnings and Cautions for Using the Immobilizer System

CAUTION

- Changes or modifications not expressly approved by the party responsible for compliance could void the user's authority to operate the equipment.
- To avoid damage to the key, do not:
 - Drop the key.
 - Get the key wet.
 - Expose the key to any kind of magnetic field.
 - Expose the key to high temperatures on places such as the instrument panel, under direct sunlight.
- If the engine does not start with the correct key, and the security indicator light keeps illuminating or flashing, the system may have a malfunction. Consult an expert repairer (we recommend an Authorised Mazda Repairer).

How to Use the Immobilizer System

NOTE

- The engine may not start and security indicator light may illuminate or flash if the key is placed in an area where it is difficult for the system to detect the signal, such as on the instrument panel or in the glove compartment. Move the key to a location within the signal range, switch the vehicle power off, and then restart the engine.
- Signals from a TV or radio station, or from a transceiver or mobile telephone could interfere with your immobilizer system. If you are using the proper key and the engine fails to start, check the security indicator light.

Arming

The system is armed when the vehicle power is switched from ON to off.

The security indicator light  in the instrument cluster flashes every 2 seconds until the system is disarmed.

Disarming

The system is disarmed when the vehicle power is switched ON with the correct programmed key. The security indicator light  illuminates for about 3 seconds and then turns off. If the engine does not start with the correct key, and the security indicator light remains illuminated or flashing, try the following:

Make sure the key is within the operational range for signal transmission. Switch the vehicle power off, and then restart the engine. If the engine does not start after 3 or more

tries, contact an expert repairer (we recommend an Authorised Mazda Repairer).

Theft-Deterrent System*

If the theft-deterrent system detects an inappropriate entry into the vehicle or the intrusion sensor detects movement in the vehicle which could result in the vehicle (with the intrusion sensor) or its contents being stolen, the alarm alerts the surrounding area of an abnormality by sounding the siren/horn and flashing the hazard warning lights.

The system will not function unless it's properly armed. So when you leave the vehicle, follow the arming procedure correctly.

Intrusion sensor*

The intrusion sensor uses ultrasonic waves to detect movement inside the vehicle and to raise an alert of an intrusion into the vehicle.

The intrusion sensor detects certain kinds of movement inside the vehicle, however, it may also respond to phenomenon outside the vehicle such as vibrations, loud noise, wind, and air currents.

Warnings and Cautions for Using the Theft-Deterrent System

CAUTION

In order for the intrusion sensor to operate appropriately, be aware of the following:

- Do not hang clothing or objects from a head restraint or a coat hook.
- Return the extension sunvisors to their original positions.
- Do not blind the intrusion sensor by covering it or placing objects over it.
- Do not allow the intrusion sensor to get soiled or wipe it with a liquid.
- Do not shock or cause an impact to the intrusion sensor or the intrusion sensor bezel.
- Do not install seats that are not Mazda genuine products.
- To prevent obstruction of intrusion sensor, do not place objects or cargo near the intrusion sensor that are higher than the head restraints.

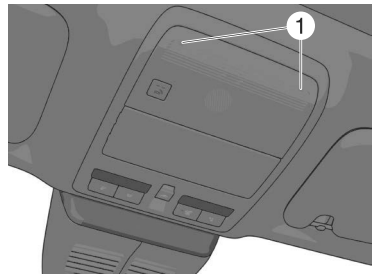

1. Intrusion sensor and intrusion sensor bezel

How to Use the Theft-Deterrent System

How to Arm the System

1. Close the windows and the panorama sunroof* securely.

NOTE

(With the intrusion sensor)

Even with a window or the panorama sunroof* open, the system can be armed, however, leaving the windows or the panorama sunroof* even partially open can invite theft, and wind blowing into the vehicle could trigger the alarm.

The intrusion sensor function can also be cancelled.

Refer to Cancelling the Intrusion Sensor (With the Intrusion Sensor).

2. Switch the vehicle power OFF.
3. Make sure the bonnet, the doors, and the liftgate are closed.
4. Press the lock button on the transmitter. The hazard warning lights will flash once.

The following method will also arm the theft-deterrent system:

Press the door-lock switch  while any door is open and then close all of the doors.

(With the advanced keyless function)

Touch the sensing area of the door lock touch sensor.

The security indicator light  in the instrument cluster flashes twice per second for 20 seconds.

5. After 20 seconds, the system is fully armed.

NOTE

- The theft-deterrent system can also be armed by activating the auto relock function with all the doors, the liftgate and the bonnet closed. Refer to Transmitter on page 4-5.
- The system will disarm if one of the following operations takes place within 20 seconds after pressing the lock button:
 - Unlocking any door.
 - Opening any door.
 - Opening the bonnet.
 - Switching the vehicle power ON. To rearm the system, do the arming procedure again.
- When the doors are locked by pressing the lock button on the transmitter while the theft-deterrent system is armed, the hazard warning lights will flash once to indicate that the system is armed.

Operation

Siren/Horn triggering conditions

The siren/horn sounds intermittently and the hazard warning lights flash for about 30 seconds when the system is triggered by any one of the following:

With the intrusion sensor

- Unlocking a door with the auxiliary key, door lock switch, or an inside door-lock knob.
- Forcing open a door, the bonnet or the liftgate.
- Opening the bonnet by operating the bonnet release handle.
- Switching the vehicle power ON without using the push button start.
- The intrusion sensor detects a movement in the vehicle.

The system will be triggered again (up to 10 times) if one of the above conditions remains

- Disconnecting the lead-acid battery terminal (the hazard warning lights do not flash).

The system will be triggered about 10 times.

Without the intrusion sensor

- Unlocking a door with the auxiliary key, door lock switch, or an inside door-lock knob.
- Forcing open a door, the bonnet or the liftgate.
- Opening the bonnet by operating the bonnet release handle.
- Switching the vehicle power ON without using the push button start.

If the system is triggered again, the lights and horn will activate until the driver's door or the liftgate is unlocked with the transmitter.

NOTE

- The liftgate does not open while the theft-deterrent system is operating.
- If the lead-acid battery goes dead while the theft-deterrent system is armed, the siren/horn will activate and the hazard warning lights will flash when the lead-acid battery is charged or replaced.

Cancelling the Intrusion Sensor (With the Intrusion Sensor)

If the theft deterrent system has been armed while any of the following conditions are present, cancel the intrusion sensor to prevent the alarm from triggering unnecessarily.

- Leaving the vehicle with a movable object, passengers or pets remaining inside.
- Leaving an object inside the vehicle that can roll around, such as when the vehicle is placed on a tilting,

unstable surface when being shipped.

- Hanging small objects/accessories in the vehicle, hanging clothing on a coat hook, or placing other items which can move easily inside the vehicle.
- Parking in an area where there is strong vibration or loud noise.
- When using a high pressure or automatic car wash.
- Continuous shock and vibration from hail or thunder and lightning is transmitted to the vehicle.
- Doors are locked with a window or the panorama sunroof* left open.
- An accessory heater or device that produces moving air and vibration operates while the theft deterrent system is armed.

NOTE

If any door or the liftgate remains closed for 30 seconds, all the doors and the liftgate automatically re-lock and the theft deterrent system arms even if a window and the panorama sunroof* is left open.

To cancel the intrusion sensor, press the intrusion sensor cancel button on the transmitter within 20 seconds after pressing the lock button.

The hazard warning lights will flash 3 times.

NOTE

To reactivate the intrusion sensor, turn off the armed theft-deterrent system and then rearm it.

The intrusion sensor is operational when the theft-deterrent system is armed. To cancel the intrusion sensor, press the intrusion sensor cancel button each time the theft-deterrent system is armed.

*Some models.

To Stop the Alarm

A triggered alarm can be turned off using any one of the following methods:

- Pressing the unlock button on the transmitter.
- Starting the engine with the push button start.
- **(With the advanced keyless function)**
 - Touching the sensing area of the door release touch sensor.
 - Pressing the electric liftgate opener while the key is being carried.

The hazard warning lights will flash twice.

To Turn Off an Armed System

An armed system can be turned off using any one of the following methods:

- Pressing the unlock button on the transmitter.
- Starting the engine with the push button start.
- **(With the advanced keyless function)**
 - Touching the sensing area of the door release touch sensor.

The hazard warning lights will flash twice.

NOTE

When the doors are unlocked by pressing the unlock button on the transmitter while the theft-deterrent system is turned off, the hazard warning lights will flash twice to indicate that the system is turned off.

Mirrors.....	5-10	Instrument Cluster (Type A).....	5-26
Warnings and Cautions for Using the Mirrors.....	5-10	Instrument Cluster.....	5-26
How to Use the Outside Mirrors.....	5-11	How to Use the Instrument Cluster.....	5-27
Convenient Ways to Use the Outside Mirrors.....	5-12	Convenient Ways to Use the Instrument Cluster.....	5-29
Warnings and Cautions for the Rearview Mirror.....	5-13	Speedometer.....	5-29
How to Use the Rearview Mirror.....	5-14	Tachometer.....	5-30
Convenient Ways to Use the Rearview Mirror.....	5-14	Odometer/Trip Meter.....	5-30
Push Button Start.....	5-15	How to Use the Odometer/Trip Meter.....	5-31
Push Button Start.....	5-15	Engine Coolant Temperature Gauge.....	5-31
Warning and Cautions for Using the Push Button Start.....	5-15	Fuel Gauge.....	5-32
How to Use the Push Button Start.....	5-16	Instrument Panel Illumination.....	5-32
Mazda M Hybrid Boost.....	5-18	How to Use the Instrument Panel Illumination.....	5-33
Mazda M Hybrid Boost (e- SKYACTIV G, e-SKYACTIV D).....	5-18	Outside Temperature Display.....	5-34
Warning and Cautions for Using the Mazda M Hybrid Boost.....	5-19	Maximum Driving Distance Display.....	5-34
How to Use the Mazda M Hybrid Boost.....	5-22	Average Fuel Economy Display.....	5-35
i-stop.....	5-23	How to Use the Average Fuel Economy Display.....	5-35
i-stop*.....	5-23	Instantaneous Fuel Economy Display.....	5-36
How to Use the i-stop.....	5-23	Deceleration Regeneration Charge Display (e-SKYACTIV G, e-SKYACTIV D).....	5-36
		Remaining AdBlue® and Maximum Driving Distance Display*.....	5-37
		Vehicle Speed Alarm*.....	5-37

i-ACTIVSENSE Status Symbol (Warning/Risk Avoidance Support System).....	5-38	Vehicle Speed Alarm*	5-50
Message Display.....	5-38	i-ACTIVSENSE Display.....	5-51
Instrument Cluster (Type B).....	5-39	Message Display.....	5-51
Instrument Cluster.....	5-39	Active Driving Display.....	5-52
Speedometer.....	5-39	Active Driving Display*	5-52
Tachometer.....	5-40	Warnings and Cautions for Using the Active Driving Display.....	5-53
Multi-information Display....	5-41	Convenient Ways to Use the Active Driving Display.....	5-54
How to Use the Multi- information Display.....	5-42	Selector Lever.....	5-55
Convenient Ways to Use the Multi-information Display....	5-43	Warning and Cautions for Using the Selector Lever.....	5-55
Odometer/Trip Meter.....	5-43	How to Use the Selector Lever.....	5-56
How to Use the Odometer/Trip Meter.....	5-44	Steering Shift Switches.....	5-59
Engine Coolant Temperature Gauge.....	5-44	Warnings and Cautions for Using the Steering Shift Switches	5-59
Fuel Gauge.....	5-45	5-59
Instrument Panel Illumination.....	5-45	How to Use the Steering Shift Switches.....	5-60
How to Use the Instrument Panel Illumination.....	5-46	Convenient Ways to Use the Steering Shift Switches.....	5-64
Outside Temperature Display.....	5-47	Gear Shift Indicator (GSI).....	5-65
Maximum Driving Distance Display.....	5-47	Gear Shift Indicator (GSI)*	5-65
Average Fuel Economy Display.....	5-48	Warning and Cautions for Using the Gear Shift Indicator (GSI).....	5-65
How to Use the Average Fuel Economy Display.....	5-48	Foot Brake.....	5-66
Instantaneous Fuel Economy Display.....	5-49	Warning and Cautions for Using the Foot Brake.....	5-66
Deceleration Regeneration Charge Display (e-SKYACTIV G, e-SKYACTIV D).....	5-49	Electric Parking Brake (EPB).....	5-67
Remaining AdBlue® and Maximum Driving Distance Display*	5-50	Electric Parking Brake (EPB)	5-67

Warning and Cautions for Using the Electric Parking Brake (EPB).....	5-67	How to Use the Light Switch.....	5-79
How to Use the Electric Parking Brake (EPB).....	5-68	Convenient Ways to Use the Light Switch.....	5-81
Convenient Ways to Use the Electric Parking Brake (EPB).....	5-69	How to Use the Fog Light Switch*.....	5-82
Brake Override System.....	5-71	Direction Indicator lever.....	5-83
Brake Override System.....	5-71	How to Use the Direction Indicator Lever.....	5-83
Warning and Cautions for Using the Brake Override System	5-71	Windscreen Wiper/Washer Switch.....	5-84
How to Use the Brake Override System.....	5-72	Windscreen Wiper/Washer Switch.....	5-84
AUTOHOLD.....	5-73	Warning and Cautions for Using the Windscreen Wiper/Washer Switch.....	5-84
AUTOHOLD.....	5-73	How to Use the Windscreen Wiper/Washer Switch.....	5-85
Warning and Cautions for Using the AUTOHOLD.....	5-73	How to Use the Rear Wiper/Washer Switch.....	5-88
How to Use the AUTOHOLD.....	5-74	Rear Window Defogger Switch.....	5-89
Hill Launch Assist (HLA).....	5-76	Rear Window Defogger Switch.....	5-89
Hill Launch Assist (HLA).....	5-76	Warnings and Cautions for Using the Rear Window Defogger Switch.....	5-89
Warning and Cautions for Using the Hill Launch Assist (HLA).....	5-76	How to Use the Rear Window Defogger Switch.....	5-90
Emergency Signal System (ESS).....	5-77	Mirror Defogger*.....	5-90
Emergency Signal System (ESS).....	5-77	How to Use the Mirror Defogger.....	5-91
Light Switch.....	5-78	Windscreen Wiper De-icer*.....	5-91
Light Switch.....	5-78	How to Use the Windscreen Wiper De-icer.....	5-92
Warnings and Cautions for Using the Light Switch.....	5-78		

Hazard Warning Lights	5-93
Hazard Warning Lights.....	5-93
How to Use the Hazard Warning Lights.....	5-93
Horn	5-94
How to Use the Horn.....	5-94
Antilock Brake System (ABS)	5-95
Antilock Brake System (ABS).....	5-95
Warning and Cautions for Using the Antilock Brake System (ABS).....	5-95
Traction Control System (TCS)	5-96
Traction Control System (TCS).....	5-96
Warning and Cautions for Using the Traction Control System (TCS).....	5-96
How to Use the Traction Control System (TCS).....	5-97
Convenient Ways to Use the Traction Control System (TCS).....	5-98
Dynamic Stability Control (DSC)	5-99
Dynamic Stability Control (DSC).....	5-99
Warning and Cautions for Using the Dynamic Stability Control (DSC).....	5-99
How to Use the Dynamic Stability Control (DSC).....	5-100

Trailer Stability Control (TSC)	5-101
Trailer Stability Control (TSC).....	5-101
Warning and Cautions for Using the Trailer Stability Control (TSC).....	5-101
How to Use the Trailer Stability Control (TSC).....	5-102
Hill Descent Control	5-103
Hill Descent Control*.....	5-103
Warnings and Cautions for Using the Hill Descent Control.....	5-103
How to Use the Hill Descent Control.....	5-104
Mazda intelligent Drive Select (Mi-Drive)	5-106
Mazda intelligent Drive Select (Mi-Drive).....	5-106
Warning and Cautions for Using the Mazda intelligent Drive Select (Mi-Drive).....	5-106
How to Use the Mazda intelligent Drive Select (Mi-Drive).....	5-107
i-ACTIV AWD	5-109
i-ACTIV AWD*.....	5-109
Warnings and Cautions for Using the i-ACTIV AWD.....	5-109
Power Steering	5-110
Power Steering.....	5-110
Tyre Pressure Monitoring System (TPMS)	5-111
Tyre Pressure Monitoring System (TPMS)*.....	5-111

Warning and Cautions for Using the Tyre Pressure Monitoring System (TPMS).....	5-111	Warnings and Cautions for Using the Emission Control System.....	5-126
How to Use the Tyre Pressure Monitoring System (TPMS)	5-113	Warnings and Cautions for Engine Exhaust (Carbon monoxide).....	5-127
Petrol Particulate Filter.....	5-115	i-ACTIVSENSE.....	5-128
Petrol Particulate Filter*	5-115	i-ACTIVSENSE.....	5-128
Diesel Particulate Filter (DPF).....	5-116	Warnings and Cautions for Using the i-ACTIVSENSE.....	5-128
Diesel Particulate Filter (DPF) (e-SKYACTIV D).....	5-116	Active Safety Technology....	5-129
Selective Catalytic Reduction (SCR) System.....	5-117	Pre-crash Safety Technology.....	5-130
Selective Catalytic Reduction (SCR) System*	5-117	i-ACTIVSENSE Status Symbol (Warning/Risk Avoidance Support System)*	5-130
Warning and Cautions for Using the Selective Catalytic Reduction (SCR) System.....	5-117	How to Use the i-ACTIVSENSE OFF switch*	5-132
How to Use the Selective Catalytic Reduction (SCR) System.....	5-118	Forward Sensing Camera (FSC).....	5-133
Refuelling.....	5-119	Forward Sensing Camera (FSC)*	5-133
Warnings and Cautions for When the Refuelling.....	5-119	Radar Sensors.....	5-137
Refuelling.....	5-120	Radar Sensors*	5-137
Fuel Requirements.....	5-122	Ultrasonic Sensors.....	5-141
Warnings and Cautions for Using the Fuel Requirements.....	5-124	Ultrasonic Sensors*	5-141
Deposit Cleaner.....	5-124	Cameras.....	5-143
Warnings and Cautions for Using the Deposit Cleaner.....	5-125	Cameras*	5-143
How to Use the Deposit Cleaner.....	5-125	Driver Monitoring Camera.....	5-145
Emission Control System....	5-126	Driver Monitoring Camera*	5-145

High Beam Control System (HBC)..... 5-146
 High Beam Control System (HBC)*..... 5-146
 Warnings and Cautions for Using the High Beam Control System (HBC)..... 5-147
 How to Use the High Beam Control System (HBC)..... 5-148

Adaptive LED Headlights (ALH).....5-150
 Adaptive LED Headlights (ALH)*..... 5-150
 Warnings and Cautions for Using the Adaptive LED Headlights (ALH)..... 5-152
 How to Use the Adaptive LED Headlights (ALH)..... 5-153

Lane Departure Warning System (LDWS)..... 5-155
 Lane Departure Warning System (LDWS)*..... 5-155
 Warnings and Cautions for Using the Lane Departure Warning System (LDWS)..... 5-155
 How to Use the Lane Departure Warning System (LDWS)..... 5-156

Blind Spot Monitoring (BSM).. 5-158
 Blind Spot Monitoring (BSM)* 5-158
 Warnings and Cautions for Using the Blind Spot Monitoring (BSM)..... 5-158
 How to Use the Blind Spot Monitoring (BSM)..... 5-159

Traffic Sign Recognition System (TSR)..... 5-163
 Traffic Sign Recognition System (TSR)*..... 5-163
 Warnings and Cautions for Using the Traffic Sign Recognition System (TSR)..... 5-163
 How to Use the Traffic Sign Recognition System (TSR)... 5-164
 Convenient Ways to Use the Traffic Sign Recognition System (TSR)..... 5-165

Distance & Speed Alert (DSA) 5-166
 Distance & Speed Alert (DSA)* 5-166
 Warnings and Cautions for Using the Distance & Speed Alert (DSA)..... 5-166
 How to Use the Distance & Speed Alert (DSA)..... 5-167

Driver Attention Alert (DAA)...5-168
 Driver Attention Alert (DAA)* 5-168
 Warnings and Cautions for Using the Driver Attention Alert (DAA)..... 5-168
 How to Use the Driver Attention Alert (DAA)..... 5-169

Driver Monitoring (DM).....5-170
 Driver Monitoring (DM)*.... 5-170
 Warnings and Cautions for Using the Driver Monitoring (DM)..... 5-171
 How to Use the Driver Monitoring (DM)..... 5-171

Front Cross Traffic Alert (FCTA)
..... 5-174

- Front Cross Traffic Alert (FCTA)* 5-174
- Warnings and Cautions for Using the Front Cross Traffic Alert (FCTA)..... 5-174
- How to Use the Front Cross Traffic Alert (FCTA)..... 5-175

Rear Cross Traffic Alert (RCTA)
..... 5-177

- Rear Cross Traffic Alert (RCTA)*
..... 5-177
- Warnings and Cautions for Using the Rear Cross Traffic Alert (RCTA)..... 5-177
- How to Use the Rear Cross Traffic Alert (RCTA)..... 5-178

Mazda Radar Cruise Control (MRCC)..... 5-179

- Mazda Radar Cruise Control (MRCC)* 5-179
- Warnings and Cautions for Using the Mazda Radar Cruise Control (MRCC)..... 5-179
- How to Use the Mazda Radar Cruise Control (MRCC)..... 5-181

Cruising & Traffic Support (CTS)..... 5-192

- Cruising & Traffic Support (CTS)* 5-192
- Warnings and Cautions for Using Cruising & Traffic Support (CTS)..... 5-192
- How to Use the Cruising & Traffic Support (CTS)..... 5-194

Lane-keep Assist System (LAS).....
..... 5-211

- Lane-keep Assist System (LAS)*
..... 5-211
- Warnings and Cautions for Using the Lane-keep Assist System (LAS)..... 5-211
- How to Use the Lane-keep Assist System (LAS)..... 5-212

Adjustable Speed Limiter (ASL)..... 5-214

- Adjustable Speed Limiter (ASL)* 5-214
- Warnings and Cautions for Using the Adjustable Speed Limiter (ASL)..... 5-214
- How to Use the Adjustable Speed Limiter (ASL)..... 5-215

Intelligent Speed Assistance (ISA)..... 5-217

- Intelligent Speed Assistance (ISA)* 5-217
- Warnings and Cautions for Using the Intelligent Speed Assistance (ISA)..... 5-217
- How to Use the Intelligent Speed Assistance (ISA)..... 5-218

Emergency Lane Keeping (ELK)..... 5-220

- Emergency Lane Keeping (ELK)* 5-220
- Warnings and Cautions for Using the Emergency Lane Keeping (ELK)..... 5-221
- How to Use the Emergency Lane Keeping (ELK)..... 5-222

Smart Brake Support (SBS)..... 5-226

Smart Brake Support (SBS)*
..... 5-226

Warnings and Cautions for Using
the Smart Brake Support
(SBS).....5-228

How to Use the Smart Brake
Support (SBS).....5-229

360° View Monitor.....5-235

360° View Monitor* 5-235

Warnings and Cautions for Using
the 360° View Monitor..... 5-239

How to Use the 360° View
Monitor..... 5-241

Convenient Ways to Use the 360°
View Monitor..... 5-251

Secondary Collision

Reduction..... 5-252

Secondary Collision
Reduction* 5-252

Warnings and Cautions for Using
the Secondary Collision

Reduction..... 5-252

How to Use the Secondary
Collision Reduction..... 5-253

Cruise Control.....5-254

Cruise Control*5-254

Warnings and Cautions for Using
the Cruise Control..... 5-254

How to Use the Cruise
Control..... 5-255

Rear View Monitor.....5-258

Rear View Monitor* 5-258

Warnings and Cautions for Using
the Rear View Monitor..... 5-259

How to Use the Rear View
Monitor..... 5-260

Parking Sensor.....5-263

Parking Sensor* 5-263

Warnings and Cautions for Using
the Parking Sensor..... 5-263

How to Use the Parking
Sensor.....5-264

Winter Driving.....5-269

Winter Driving..... 5-269

Snow Tyres..... 5-270

Tyre Chains..... 5-270

Turbocharger..... 5-272

Turbocharger (e-SKYACTIV G, e-
SKYACTIV D)..... 5-272

Warnings and Cautions for Using
the Turbocharger..... 5-272

How to Use the
Turbocharger..... 5-273

MEMO

Warnings and Cautions for Using the Mirrors

WARNING

Be sure to look over your shoulder before changing lanes.

Changing lanes without taking into account the actual distance of a vehicle in the convex mirror is dangerous. You could have a serious accident. What you see in the convex mirror is closer than it appears.

Always return the outside mirrors to the driving position before you start driving.

Driving with the outside mirrors folded in is dangerous. Your rear view will be restricted, which could lead to an unexpected accident.

Do not touch the outside mirrors while they are folding in and out.

Touching an outside mirror while it is folding in or out is dangerous. Your hands could get caught which could cause an injury or the door mirror could be damaged.

Use the switch to set the outside mirrors.

Setting the outside mirrors manually is dangerous. The outside mirrors will not lock into place, which could obstruct visibility.

Always operate the electric retractable mirrors with the vehicle parked in a safe place.

Operating the electric retractable mirrors while driving is dangerous. Wind pressure could damage the outside mirrors, making it impossible to return them to the driving position and to see behind you.

Do not adjust the outside mirrors while driving the vehicle.

Adjusting the outside mirrors while driving the vehicle is dangerous as doing so could distract your attention from the road ahead and lead to an accident.

CAUTION

Operate the folding switch to fold in or out the outside mirrors. If you unfold the outside mirrors manually, they will not be in a secured position and you will be unable to check the view to the rear of the vehicle.

How to Use the Outside Mirrors

Folding in and out the outside mirrors

1. Switch the vehicle power ACC or ON.
2. Press the folding mirror button to fold the mirror in. Press again to fold out.

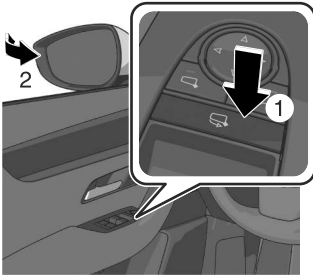

Adjusting the Outside Mirror Angle

1. Switch the vehicle power ACC or ON.
2. Press the select button on the side of the outside mirror to be adjusted.
The indicator light turns on.

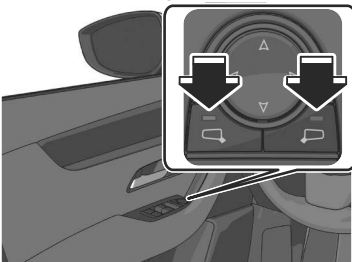

3. Press the adjustment switch to adjust the angle of the outside mirror.

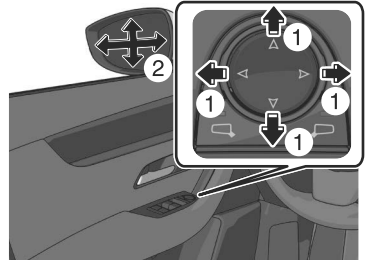

4. Press the select button on the side of the outside mirror that has been adjusted.
The indicator light turns off.

Convenient Ways to Use the Outside Mirrors

Driving Position Memory*

The angle of the outside mirrors can be programmed to the Driving Position Memory.

Refer to Driving Position Memory on page 3-28.

Auto fold function

When locking/unlocking the doors while the vehicle power is switched OFF, the outside mirrors automatically fold in and out.

When the outside mirrors are folded in and the vehicle power is switched ON, or the engine is started, the outside mirrors fold out automatically.

Turn the auto fold function on using the centre display.

Refer to Mazda Connect Owner's Manual or consult an expert repairer (we recommend an Authorised Mazda Repairer).

NOTE

If you press the folding switch to fold in the outside mirrors, they will not fold out automatically when unlocking the doors. Press the folding switch to fold out the outside mirrors.

Operation function after engine is stopped

The angle of the outside mirrors can be adjusted and they can be folded in and out for about 40 seconds after the vehicle power is switched from ON to OFF.

Auto tilt-down outside mirror function for reversing*

The outside mirrors can be set to tilt downwards automatically when reversing the vehicle. When the vehicle is finished reversing, the outside mirrors return to their original angle.

1. Press the select switch on the side of the door mirror to be tilted down.

Turn on the indicator light of the select switch.

2. Shift the selector lever to the R position.

The outside mirror on the side where you pressed the select switch will tilt downward.

NOTE

When any of the following condition is met, the outer mirrors return to their normal positions.

- The vehicle power is switched to a position other than ON.
- The shift selector lever is shifted to a position other than R.
- The select switch is pressed again.

Automatic glare prevention function*

In conjunction with the glare prevention function of the auto-type rearview mirror, only the driver's side outside mirror reduces the light from the headlights of on-coming vehicles.

Driver's side wide-angle mirror*

A wide-angle mirror has two curvatures on its surface and it is divided into an outer and an inner sections by a boundary line. The inner section is a standard convex mirror. The outer section provides a larger area of visibility with the same area.

This combination improves visibility when changing lanes.

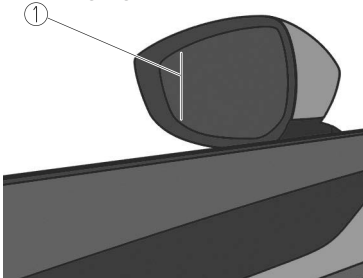

Objects visible outer and inner sections of the wide-angle mirror are at different distances. Objects that displayed in the outer section are actually farther away than the inner section.

Operation Function After Vehicle power is Switched OFF

The outside mirrors can be operated for about 40 seconds after the vehicle power is switched from ON to off with all doors closed. If any door is opened, the outside mirrors will stop operating.

Warnings and Cautions for the Rearview Mirror

! WARNING

Do not stack luggage higher than the seatback.

Loading luggage higher than the seatback is dangerous. The rearview mirror visibility may be obstructed, which may result in a collision with another vehicle when changing lanes.

How to Use the Rearview Mirror

Move and adjust the rearview mirror body.

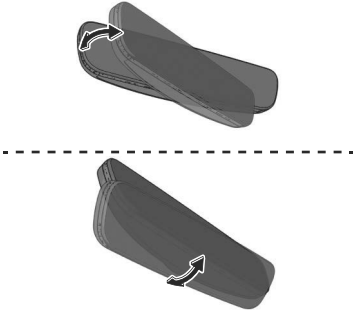

Convenient Ways to Use the Rearview Mirror

Glare prevention function

Prevents glare from the headlights of rear on-coming vehicles.

Manual type

Normally, use the rearview mirror with the lever pressed.

Pull the lever toward you.

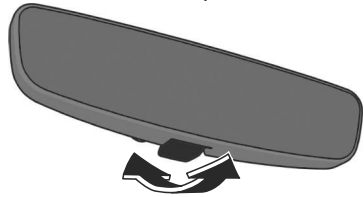

Automatic type

Automatically operates when the vehicle power is switched ON and the selector lever is in a position other than R.

Push Button Start

Press the push button start to start/stop the engine or to switch the vehicle power position (OFF/ACC/ON).

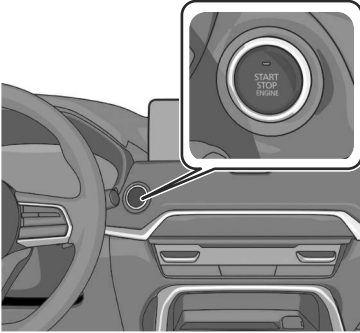

Vehicle power position

OFF

All electrical accessories cannot be used.

ACC

Some electrical accessories such as audio can be used.

ON

All electrical accessories can be used.

Warning and Cautions for Using the Push Button Start

! WARNING

Before leaving the driver's seat, always switch the vehicle power off, set the parking brake, and make sure the selector lever is in the P position. Leaving the driver's seat without switching the vehicle power off, setting the parking brake, and shifting the selector lever to the P position is dangerous. Unexpected vehicle movement could occur which could result in an accident. In addition, if your intention is to leave the vehicle for even a short period, it is important to switch the vehicle power position to OFF, as leaving it in another position will disable some of the vehicle's security systems and run the lead-acid battery down.

Radio waves from the key may affect medical devices such as pacemakers. Before using the key near people who use medical devices, ask the medical device manufacturer or your physician if radio waves from the key will affect the device.

Other than for an emergency situation, do not attempt to stop the engine while driving the vehicle. If the engine is stopped while driving the vehicle, loss of brake power and power steering functions could occur, making it difficult to control the vehicle which could result in an accident.

CAUTION

- If the KEY warning light (red)  is displayed, or the push button start indicator light (amber) flashes, this could indicate a problem with the engine starting system. This may prevent the engine from starting or from switching the vehicle power position to ACC or ON. Have your vehicle inspected at an expert repairer (we recommend an Authorised Mazda Repairer) as soon as possible. Refer to KEY Warning Light (Red) on page 8-50.
- Before leaving the vehicle, make sure that the vehicle power is switched OFF.

How to Use the Push Button Start

The push button start starts/stops the engine and switches the vehicle power position depending on the vehicle status and the driver's operation.

Starting the Engine

1. Make sure that the parking brake is applied.
2. Make sure that the selector lever is in the P position.
3. Depress the brake pedal.
The push button start indicator light (green) and the KEY indicator light (green)  in the instrument cluster turn on.

4.

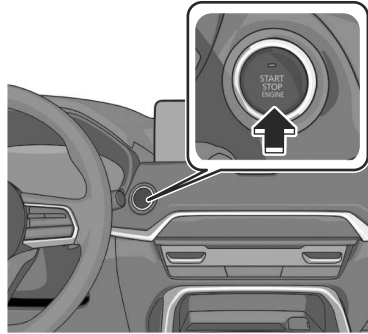

The engine starts and the KEY indicator light (green)  in the instrument cluster turns off.
(e-SKYACTIV G, e-SKYACTIV D)

The READY indicator light **READY** in the instrument cluster turns on.

NOTE

- Do not use high engine speeds until reaching the operating temperature.
- **(Germany)**
Drive immediately after start the engine.

Stopping The Engine

1. Stop the vehicle.
2. Shift the selector lever to the P position.
- 3.

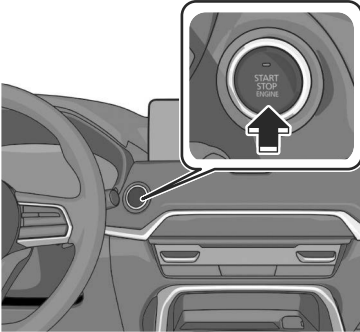

The engine stops and the vehicle power is switched OFF.

(e-SKYACTIV G, e-SKYACTIV D)

The READY indicator light **READY** in the instrument cluster turns off.

NOTE

If the engine is turned off while the selector lever is in a position other than P, the AUTO P (parking lock) function operates and the vehicle power is switched OFF. For safety, shift the selector lever to the P position and switch the vehicle power OFF.

Switching the Vehicle power Position

Press the push button start without depressing the brake pedal.

Each time the push button start is pressed, the vehicle power position is switched in the order of ACC, ON, and OFF.

When the vehicle power is switched to ACC, the steering wheel is unlocked and the push button start indicator light (amber) turns on.

When the vehicle power is switched OFF and a door is opened/closed or locked, the steering wheel is locked

and the push button start indicator light (amber) turns off.

NOTE

If you leave the vehicle power switched to ACC while the selector lever is in the P position, the vehicle power is switched OFF in about 25 minutes.

Mazda M Hybrid Boost (e-SKYACTIV G, e-SKYACTIV D)

Mazda M Hybrid Boost is a system that improves driving performance and fuel economy by assisting the engine with a motor and charging with regenerative braking according to the driving conditions of the vehicle. Because the Mazda M Hybrid Boost Battery charges the vehicle while driving, charging from outside of the vehicle is not necessary.

Warning and Cautions for Using the Mazda M Hybrid Boost

WARNING

Do not touch the high temperature or high current areas.

The following areas are high temperature and high current and may cause serious burns and electrical shock if touched.

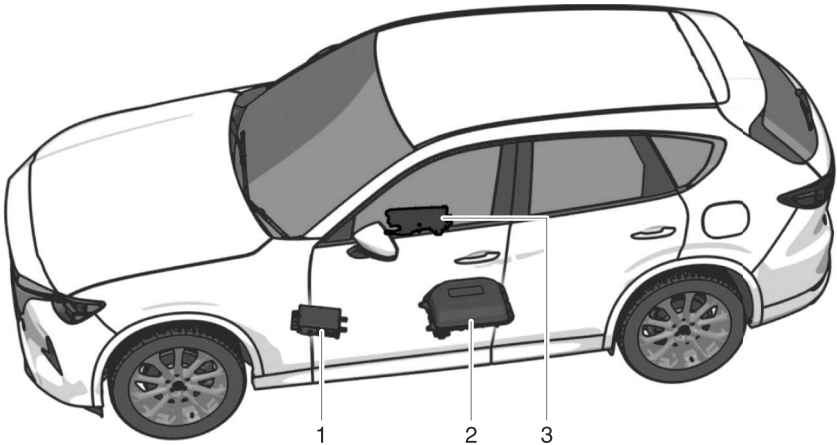

1. DC-DC converter
2. Mazda M Hybrid Boost Battery
3. Inverter

To reduce the risk of burns or electrical shock, always heed the following precautions.

- Never remove and disassemble the brackets and connectors securing the terminal part, wiring harness, and the Mazda M Hybrid Boost Battery.
- Never touch the Mazda M Hybrid Boost Battery because it becomes extremely hot under direct sunlight or after driving.
- Never touch the Mazda M Hybrid Boost Battery when it is wet because it is especially dangerous.

To ensure safe and correct handling of the Mazda M Hybrid Boost Battery, always heed the following.

- Do not remove the Mazda M Hybrid Boost Battery.
- Do not resell, transfer, or modify the Mazda M Hybrid Boost Battery.
- Do not make secondary use of the Mazda M Hybrid Boost Battery.

If the Mazda M Hybrid Boost Battery is not handled properly, the following may occur which could lead to serious injury or death.

- Touching an unattended or illegally abandoned Mazda M Hybrid Boost Battery may cause electrocution.
- If the Mazda M Hybrid Boost Battery is used on a vehicle other than the one it came equipped on (including modified vehicles), accidents such as electric shock, heat generation, smoking, combustion, and explosions, or an electrolyte leakage may occur.

Appropriate disposal of the Mazda M Hybrid Boost Battery.

If the Mazda M Hybrid Boost Battery is not collected and disposed of appropriately, such as by leaving it unattended or illegally abandoning, some other person may touch it which could cause electrocution leading to serious injury.

Never touch the areas where high current is flowing.

Never touch an Mazda M Hybrid Boost system related part. Otherwise, it could result in serious injury such as burns and electrical shock.

Never touch electrical wiring that may be protruding into or outside of the cabin.

Otherwise, it could result in serious injury such as burns and electrical shock.

Never touch any area where electrolyte is visible or electrolyte is leaking from the area.

If electrolyte from the Mazda M Hybrid Boost battery gets in the eyes or on the skin, it could cause loss of vision or skin reactions. If electrolyte comes into contact with the eyes, do not rub them, and after flushing with water for 15 minutes or longer, seek medical attention immediately. In addition, if electrolyte comes into contact with the skin, wash the areas with soap and water thoroughly. If you feel any abnormality in your body, seek medical attention immediately.

Do not come near the vehicle if electrolyte is leaking from the Mazda M Hybrid Boost Battery.

Even if the Mazda M Hybrid Boost Battery is damaged, large quantities of electrolyte will not flow out due to the internal structure of the Mazda M Hybrid Boost Battery, however, in the unlikely event that it does, it will produce steam. The steam contains properties that can irritate the eyes and skin, and could cause acute poisoning if absorbed.

Never approach objects that are on fire or extremely hot.

Electrolyte in the Mazda M Hybrid Boost battery may cause a fire. If the vehicle catches fire, extinguish the fire using a fire extinguisher (type ABC, BC, or C). Only extinguish a fire with water when a large amount of water is available such as from a fire hydrant. Using a small amount of water may cause the fire to spread.

 **CAUTION**

- If the driver's door is opened under the following conditions, the vehicle determines that the driver is trying to leave the vehicle, a warning sound notifying the driver of possible danger is activated, and the warning indication is displayed.
 - The engine is running.
 - The selector lever is in a position other than P or N.
- If there is a problem with the Mazda M Hybrid Boost system, a warning is displayed.

How to Use the Mazda M Hybrid Boost

Mazda M Hybrid Boost automatically switches between engine assist by the motor and charging by regenerative braking according to the driving conditions of the vehicle.

The Mazda M Hybrid Boost power generating status is displayed on the system operation status display of the fuel economy monitor.

Refer to the Mazda Connect Owner's Manual or consult an expert repairer (we recommend an Authorised Mazda Repairer).

NOTE

Drive the vehicle for about 30 minutes once every 2 to 3 months because self-discharge occurs gradually if the vehicle is not driven for a long period of time. If the Mazda M Hybrid Boost Battery discharges completely and the Mazda M Hybrid Boost system cannot be activated, contact an expert repairer (we recommend an Authorised Mazda Repairer).

Replacement and Disposal of Mazda M Hybrid Boost Battery

Technical knowledge and skill are necessary in handling the Mazda M Hybrid Boost Battery. The Mazda M Hybrid Boost Battery is collected to prevent accidents involving it. When scrapping your vehicle, replacing the Mazda M Hybrid Boost Battery, or disposing of the Mazda M Hybrid Boost Battery, consult an expert repairer (we recommend an Authorised Mazda Repairer). Please cooperate in ensuring that the vehicle's Mazda M Hybrid Boost Battery is collected.

Mazda M Hybrid Boost Malfunction

If the vehicle receives an impact of a certain level or greater in a collision, the Mazda M Hybrid Boost system stops. In this case, the charging system warning light turns on and the Mazda M Hybrid Boost system may not activate. Park the vehicle in a safe place immediately and contact an expert repairer (we recommend an Authorised Mazda Repairer).

i-stop*

i-stop is a function that automatically stops and restarts the engine to improve fuel economy, reduce exhaust emissions, and idling noise.

How to Use the i-stop

Enabling Operation of the i-stop Function

The i-stop function becomes operational when all of the following conditions are met.

- After engine warm-up.
- After starting the engine and driving once.
- All doors, liftgate, and bonnet are closed.
- The driver's seat belt is fastened.
- The air conditioner is not operated with the airflow mode in the  position.
- The temperature setting switch of the air conditioner is in a position other than maximum heating or maximum cooling (A/C ON) position.
- The vehicle's interior temperature and the set temperature for the air conditioner are nearly the same.
- The ambient temperature is not too low or too high.
- The atmospheric pressure is not low (when not driving at high altitudes).
- The selector lever is in the D position.
- The automatic transmission fluid has warmed up sufficiently.
- The automatic transmission fluid temperature is not abnormally high.
- The steering wheel is almost in the straight-ahead position (the i-stop function may not operate even with the steering wheel in the straight-ahead position if force is applied to the steering wheel).
- The vehicle is not on a steep slope.
- The vehicle is not stopped suddenly.
- **(SKYACTIV-G)**
 - The brake vacuum is sufficiently high.

- The lead-acid battery is in good condition.
- The brake pedal is depressed.
- **(e-SKYACTIV G, e-SKYACTIV D)**
 - The temperature and the state of charge of the Mazda M Hybrid Boost Battery are good.
 - The motor and regenerative braking are in good condition.
- **(e-SKYACTIV D)**

The particulate matter (PM) is not being removed by the diesel particulate filter (DPF).

Operating the i-stop Function

SKYACTIV-G

(Mazda Radar Cruise Control with Stop & Go function (MRCC with Stop & Go function)/Cruising & Traffic Support (CTS) is not in use)

1. Stop the vehicle.

The i-stop function operates and the i-stop indicator light (green) ^{i-stop} turns on.

When AUTOHOLD is operating, the i-stop function continues to operate even if you release your foot from the brake pedal.
2. **(AUTOHOLD is not operating)**

Release your foot from the brake pedal.

The engine restarts.

(AUTOHOLD is operating)
Depress the brake pedal.
The engine restarts.

(Mazda Radar Cruise Control with Stop & Go function (MRCC with Stop & Go function)/Cruising & Traffic Support (CTS) is in use)

1. When the vehicle is stopped by the stop and hold control of MRCC/CTS, the i-stop function operates and the i-stop indicator light (green) ^{i-stop} turns on.

2. Depress the accelerator pedal or press the RES switch on the cruise control switch.
The engine restarts.

e-SKYACTIV G, e-SKYACTIV D

(Mazda Radar Cruise Control with Stop & Go function (MRCC with Stop & Go function)/Cruising & Traffic Support (CTS) is not in use)

1. When the Mazda M Hybrid Boost system determines that the engine does not need power during driving, i-stop function operates and the i-stop indicator light (green) ^{i-stop} turns on.
2. The engine restarts when the accelerator pedal is depressed or the Mazda M Hybrid Boost system determines that engine power is required.

(Mazda Radar Cruise Control with Stop & Go function (MRCC with Stop & Go function)/Cruising & Traffic Support (CTS) is in use)

1. When the Mazda M Hybrid Boost system determines that the engine does not need power during driving, i-stop function operates and the i-stop indicator light (green) ^{i-stop} turns on.
2. Depress the accelerator pedal or press the RES switch on the steering switch.
The engine restarts when the Mazda M Hybrid Boost determines that engine power is required.

NOTE

- **(SKYACTIV-G)**

After 2 minutes since i-stop function has operated, the engine restarts.

- If the lead-acid battery terminals are disconnected, the i-stop function may not operate right after connecting the lead-acid battery terminals. In addition, if the lead-acid battery is replaced, the i-stop functions require checking. Consult an expert repairer (we recommend an Authorised Mazda Repairer).

Stopping the Operation of the i-stop Function

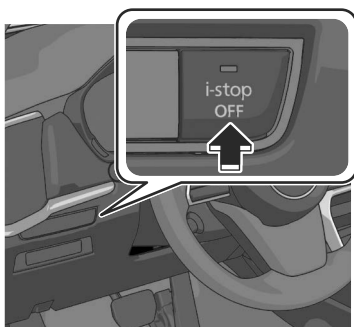

The i-stop function stops and the i-stop OFF switch indicator light turns on.

NOTE

When the i-stop function is stopped and the engine is stopped, the i-stop function becomes operational again the next time the engine is started.

Instrument Cluster

The screen display informs you of the vehicle information.

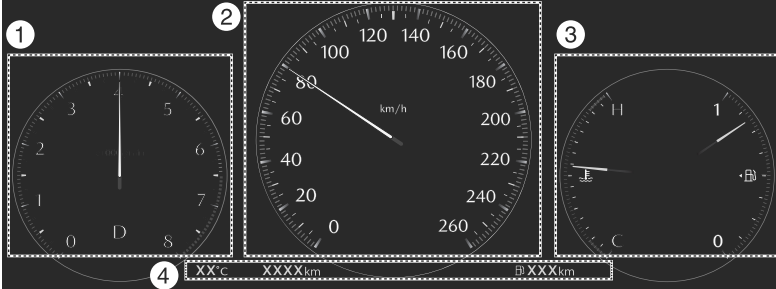

- ① Displays the tachometer.
The display differs depending on the drive mode.
- ② Displays the speedometer and vehicle information using messages.
Changes depending on the drive mode and the system being used.
- ③ Displays the engine coolant temperature gauge and the fuel gauge.
The display is changed using the INFO switch.
- ④ Displays the ambient temperature/odometer/trip meter, maximum driving distance, and vehicle information using messages.

How to Use the Instrument Cluster

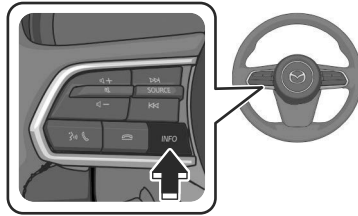

The display changes each time the INFO switch is pressed.

1

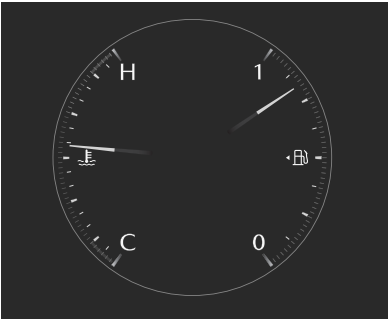

2

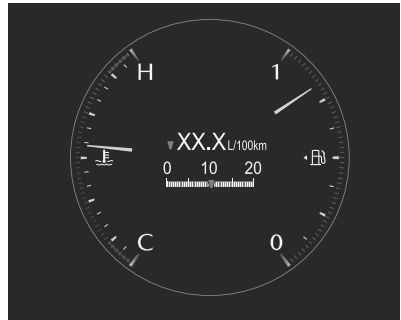

4



3



1. Basic display

Instrument Cluster (Type A)

2. Average fuel economy display
Instantaneous fuel economy display
Deceleration regeneration charge display (e-SKYACTIV G, e-SKYACTIV D)
3. i-ACTIVSENSE status symbol (Warning/Risk avoidance support system)
4. Message display*¹

*¹ Displayed only when a warning occurs.

The screen will switch automatically when some i-ACTIVSENSE systems are used.

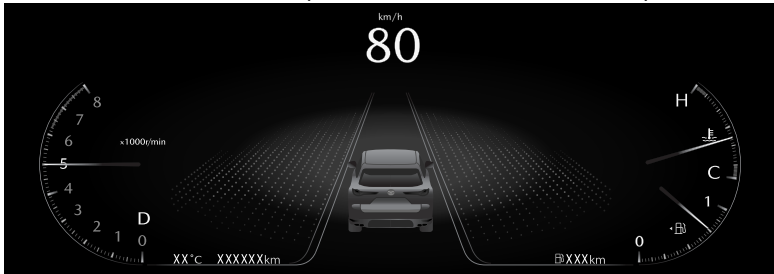

Convenient Ways to Use the Instrument Cluster

Display information can be switched using Settings in Mazda Connect. Refer to the Settings section in the Mazda Connect Owner's Manual.

Speedometer

The speedometer indicates the speed of the vehicle.

Tachometer

The tachometer shows engine speed in thousands of revolutions per minute (rpm).

CAUTION

Do not run the engine with the tachometer needle in the RED ZONE. This may cause severe engine damage.

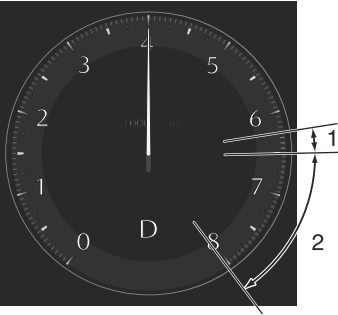

1. STRIPED ZONE^{*1}
2. RED ZONE^{*1}

^{*1} The range varies depending on the type of gauge.

NOTE

When the tachometer needle enters the STRIPED ZONE, this indicates to the driver that the gears should be shifted before entering the RED ZONE.

Odometer/Trip Meter

Odometer

The odometer records the total distance the vehicle has been driven.

Trip meter

The driving distance for a specified interval is indicated. Two types (TRIP A, TRIP B) of interval distance can be measured.

How to Use the Odometer/Trip Meter

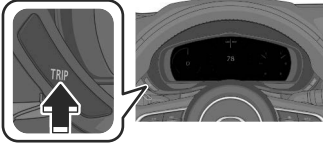

The display changes each time the TRIP switch is pressed.

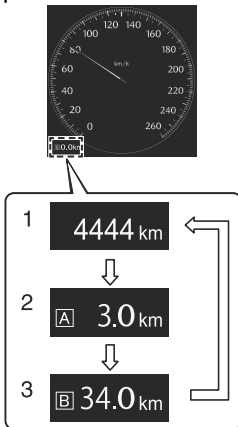

1. Odometer display
2. Trip meter A display
3. Trip meter B display

When returning the trip meter to "0", press the TRIP switch for 2 seconds or longer while the trip meter is displayed.

NOTE

If the lead-acid battery is disconnected for vehicle maintenance or other reasons, the trip meter display returns to "0".

Engine Coolant Temperature Gauge

Displays the engine coolant temperature. The blue range of the gauge indicates that the engine coolant temperature is low, and the red range of the gauge indicates that the engine coolant temperature is high and overheating.

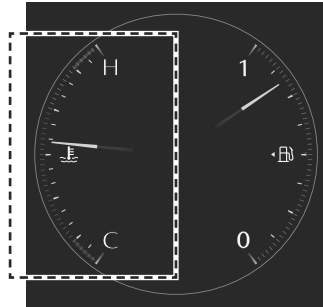

! CAUTION

If the engine coolant temperature gauge needle is in the red range, there is the possibility of overheating. Drive slowly to reduce engine load. Refer to Taking Action with Overheating on page 8-20.

Fuel Gauge

The fuel gauge shows approximately how much fuel is remaining in the tank when the vehicle power is switched ON.

When the fuel tank is full, 1 is indicated, and as the level lowers the needle approaches 0.

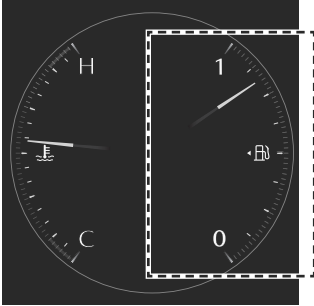

NOTE

- After refuelling, it may require some time for the indicator to stabilize. In addition, the indicator may deviate while driving on a slope or curve since the fuel moves in the tank.
- The direction of the arrow  indicates that the fuel-filler flap is on the left side of the vehicle.

Instrument Panel Illumination

(Without auto-light control)

When the lights are turned on with the vehicle power switched ON, the brightness of the instrument panel illumination is dimmed.

(With auto-light control)

When the lights are turned on with the vehicle power switched ON, the brightness of the instrument panel illumination is dimmed. However, when the light sensor detects that the surrounding area is bright such as when the lights are turned on in the daytime, the instrument panel illumination does not dim.

NOTE

(With auto-light control)

When the vehicle power is switched ON in the early evening or at dusk, the instrument panel illumination is dimmed for several seconds until the light sensor detects the brightness of the surrounding area, however, the dimming may cancel after the brightness is detected.

How to Use the Instrument Panel Illumination

Brightening the instrument panel illumination

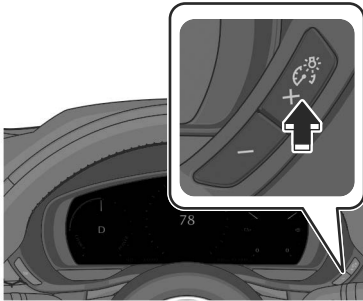

Dimming the instrument panel illumination

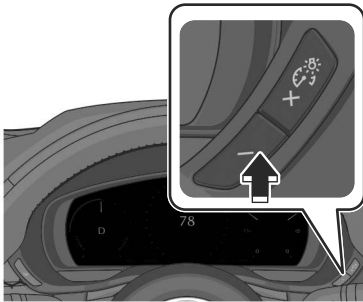

If you press the - switch again while the instrument panel illumination is at maximum dimness, a sound is activated to notify you that the dimmer setting is at maximum dimness.

Function for cancelling illumination dimmer

The illumination dimmer can be cancelled by pressing the + switch while the instrument cluster is at maximum dimness and while the vehicle power is switched ON. If you press the + switch again while the illumination dimmer is cancelled, a sound is activated to notify you that it is cancelled. If the instrument cluster's visibility is reduced due to glare from surrounding brightness, cancel the illumination dimmer.

Outside Temperature Display

When the vehicle power is switched ON, the outside temperature is displayed.



NOTE

The outside temperature display may differ from the actual outside temperature depending on the surroundings and vehicle conditions.

Outside Temperature Warning*

When the outside temperature is low, the indication flashes and a beep sound is heard to warn the driver of the possibility of icy roads.

If the outside temperature is lower than about 4 °C (39 °F), the outside temperature display and the ❄️ mark flashes for about 3 seconds and a beep sound is heard once.

NOTE

If the outside temperature is lower than -20 °C (-4 °F), the beep sound does not operate. However, the ❄️ mark illuminates.

Maximum Driving Distance Display

The maximum driving distance is calculated and displayed based on the current remaining fuel tank level and the fuel economy. When the maximum driving distance is 50 km (30 miles) or farther, the maximum driving distance indication decreases in 10 km (10 mile) increments, and when the maximum driving distance is 50 km (30 miles) or shorter, it decreases in 1 km (1 mile) increments.

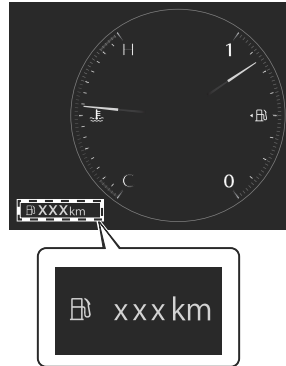

NOTE

The maximum driving distance is just an approximate numerical value and differs from the actual driving distance. Drive the vehicle while checking the fuel gauge.

Average Fuel Economy Display

This mode displays the average fuel economy by calculating the total travelled distance and the total fuel consumption since the vehicle was purchased or the past data was reset. The average fuel economy is calculated and displayed every 30 seconds.

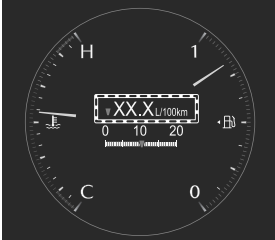

The average fuel economy is also displayed by a red arrow in the instantaneous fuel economy display.

How to Use the Average Fuel Economy Display

To reset the displayed average fuel economy data, press the INFO switch for 2 seconds or longer.

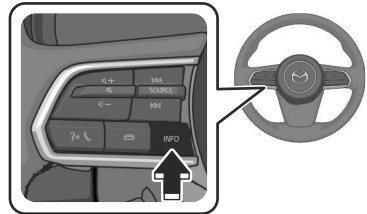

After resetting the data, - - - L/100 km (- - - mpg) is displayed until the average fuel economy is recalculated and displayed.

Instantaneous Fuel Economy Display

This displays the current fuel economy by calculating the amount of fuel consumption and the distance travelled.

(e-SKYACTIV G, e-SKYACTIV D)

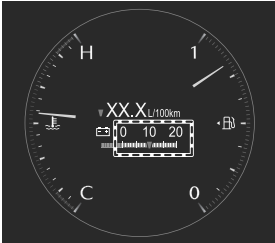

(SKYACTIV-G)

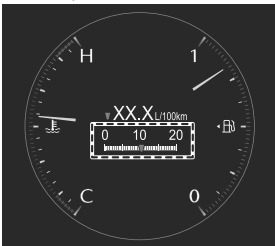

NOTE

- Displays the 0 position when the vehicle speed decreases to a constant speed or slower.
- The arrow on the scale indicates the average fuel economy.

Deceleration Regeneration Charge Display (e-SKYACTIV G, e-SKYACTIV D)

This displays the status of the charging produced by deceleration regeneration.

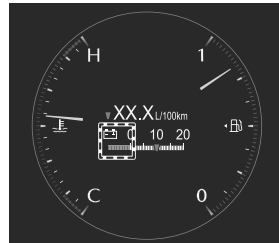

Remaining AdBlue® and Maximum Driving Distance Display*

The maximum driving distance is calculated and displayed based on the remaining amount of AdBlue®. The indication displays when the remaining amount of AdBlue® is depleted.

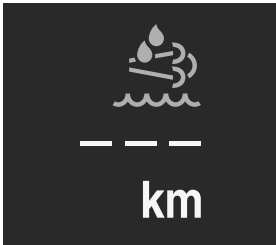

Vehicle Speed Alarm*

In this mode, the current setting for the vehicle speed alarm is displayed. You can change the vehicle speed setting at which the warning is triggered.

NOTE

The vehicle speed alarm display is activated at the same time the beep sound is heard.

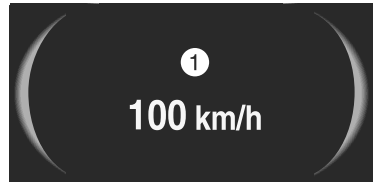

1. "Speed Alert" message is displayed

The vehicle speed alarm can be set using the centre display. Refer to the Settings section in the Mazda Connect Owner's Manual.

NOTE

Always set the vehicle speed according to the laws and regulations of the country/city in which the vehicle is driven. In addition, always verify the speed of the vehicle using the speedometer.

i-ACTIVSENSE Status Symbol (Warning/Risk Avoidance Support System)

Displays the on/off status of each i-ACTIVSENSE system.



Message Display

Displays a message to notify the user of the system operation status and malfunctions or abnormalities. Follow the instructions indicated on the display. Refer to How to Use the Instrument Cluster on page 5-27.

Instrument Cluster

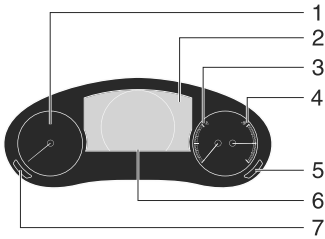

- ① Tachometer
- ② Multi-information Display
- ③ Engine Coolant Temperature Gauge
- ④ Fuel Gauge
- ⑤ Instrument Panel Illumination Switch
- ⑥ Speedometer
- ⑦ TRIP Switch

Speedometer

The speedometer indicates the speed of the vehicle.

Tachometer

The tachometer shows engine speed in thousands of revolutions per minute (rpm).

⚠ CAUTION

Do not run the engine with the tachometer needle in the RED ZONE. This may cause severe engine damage.

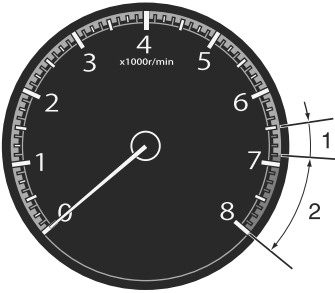

1. STRIPED ZONE*¹
2. RED ZONE*¹

*¹ The range varies depending on the type of gauge.

NOTE

When the tachometer needle enters the STRIPED ZONE, this indicates to the driver that the gears should be shifted before entering the RED ZONE.

Multi-information Display

The screen display informs you of the vehicle information.

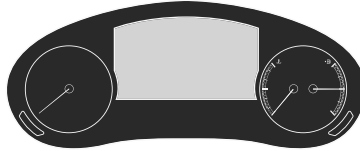

The multi-information display indicates the following information.

- Speedometer
- Odometer
- Trip meter
- Outside temperature
- Maximum driving distance
- Average fuel economy
- Current fuel economy
- Deceleration regeneration charge display (e-SKYACTIV G, e-SKYACTIV D)
- i-ACTIVSENSE display
- Vehicle speed alarm*
- Door-ajar/liftgate-ajar/bonnet-ajar warning indication*¹
- Message display

*¹ Displayed when opening door/liftgate/bonnet.

How to Use the Multi-information Display

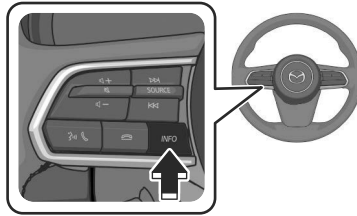

The screen content changes each time the INFO switch is pressed.

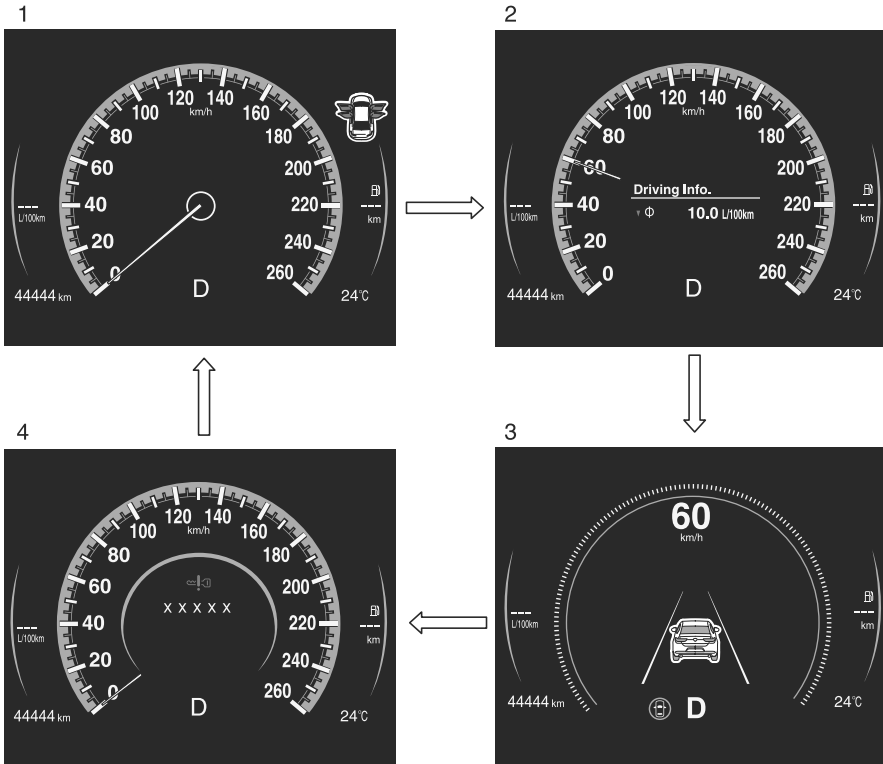

1. Basic display
2. Drive information display
3. i-ACTIVSENSE display
4. Message display*¹

*¹ Displayed only when a warning occurs.

Convenient Ways to Use the Multi-information Display

The type of display for the fuel economy and the maximum driving distance can be changed. Refer to the Settings section in the Mazda Connect Owner's Manual.

Odometer/Trip Meter

Odometer

The odometer records the total distance the vehicle has been driven.

Trip meter

The driving distance for a specified interval is indicated. Two types (TRIP A, TRIP B) of interval distance can be measured.

Instrument Cluster (Type B)

How to Use the Odometer/Trip Meter

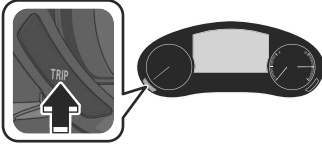

The display changes each time the TRIP switch is pressed.

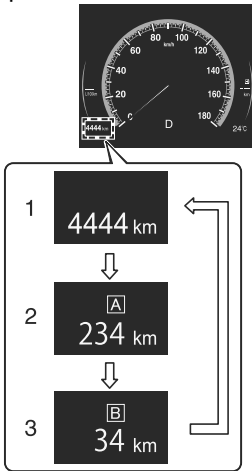

1. Odometer display
2. Trip meter A display
3. Trip meter B display

When returning the trip meter to “0”, press the TRIP switch for 2 seconds or longer while the trip meter is displayed.

NOTE

If the lead-acid battery is disconnected for vehicle maintenance or other reasons, the trip meter display returns to “0”.

Engine Coolant Temperature Gauge

Displays the engine coolant temperature. The blue range of the gauge indicates that the engine coolant temperature is low, and the red range of the gauge indicates that the engine coolant temperature is high and overheating.

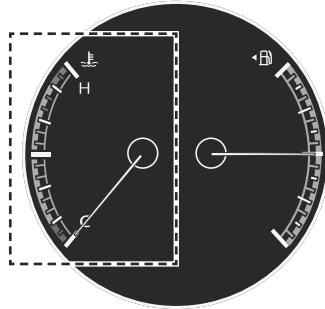

CAUTION

If the engine coolant temperature gauge needle is in the red range, there is the possibility of overheating. Drive slowly to reduce engine load. Refer to Taking Action with Overheating on page 8-20.

Fuel Gauge

The fuel gauge shows approximately how much fuel is remaining in the tank when the vehicle power is switched ON.

When the fuel tank is full, 1 is indicated, and as the level lowers the needle approaches 0.

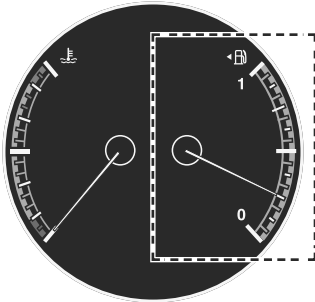

NOTE

- After refuelling, it may require some time for the indicator to stabilize. In addition, the indicator may deviate while driving on a slope or curve since the fuel moves in the tank.
- The direction of the arrow  indicates that the fuel-filler flap is on the left side of the vehicle.

Instrument Panel Illumination

(Without auto-light control)

When the lights are turned on with the vehicle power switched ON, the brightness of the instrument panel illumination is dimmed.

(With auto-light control)

When the lights are turned on with the vehicle power switched ON, the brightness of the instrument panel illumination is dimmed. However, when the light sensor detects that the surrounding area is bright such as when the lights are turned on in the daytime, the instrument panel illumination does not dim.

NOTE

(With auto-light control)

When the vehicle power is switched ON in the early evening or at dusk, the instrument panel illumination is dimmed for several seconds until the light sensor detects the brightness of the surrounding area, however, the dimming may cancel after the brightness is detected.

How to Use the Instrument Panel Illumination

Brightening the instrument panel illumination

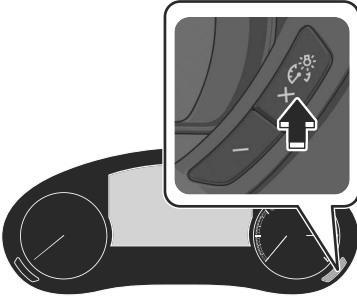

Dimming the instrument panel illumination

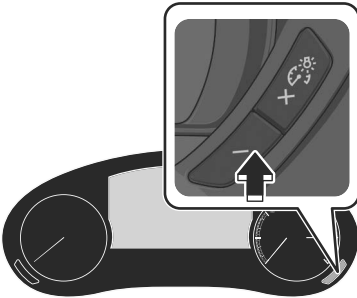

If you press the - switch again while the instrument panel illumination is at maximum dimness, a sound is activated to notify you that the dimmer setting is at maximum dimness.

Function for cancelling illumination dimmer

The illumination dimmer can be cancelled by pressing the + switch while the instrument cluster is at maximum dimness and while the vehicle power is switched ON. If you press the + switch again while the illumination dimmer is cancelled, a sound is activated to notify you that it is cancelled. If the instrument cluster's visibility is reduced due to glare from surrounding brightness, cancel the illumination dimmer.

Outside Temperature Display

When the vehicle power is switched ON, the outside temperature is displayed.

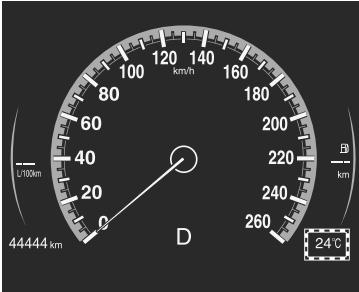

NOTE

The outside temperature display may differ from the actual outside temperature depending on the surroundings and vehicle conditions.

Outside Temperature Warning*

When the outside temperature is low, the indication flashes and a beep sound is heard to warn the driver of the possibility of icy roads.

If the outside temperature is lower than about 4 °C (39 °F), the outside temperature display and the ❄️ mark flashes for about 3 seconds and a beep sound is heard once.

NOTE

If the outside temperature is lower than -20 °C (-4 °F), the beep sound does not operate. However, the ❄️ mark illuminates.

Maximum Driving Distance Display

The maximum driving distance is calculated and displayed based on the current remaining fuel tank level and the fuel economy. When the maximum driving distance is 50 km (30 miles) or farther, the maximum driving distance indication decreases in 10 km (10 mile) increments, and when the maximum driving distance is 50 km (30 miles) or shorter, it decreases in 1 km (1 mile) increments.

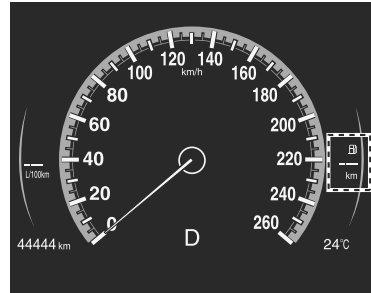

NOTE

The maximum driving distance is just an approximate numerical value and differs from the actual driving distance. Drive the vehicle while checking the fuel gauge.

Average Fuel Economy Display

This mode displays the average fuel economy by calculating the total travelled distance and the total fuel consumption since the vehicle was purchased or the past data was reset. The average fuel economy is calculated and displayed every 30 seconds.

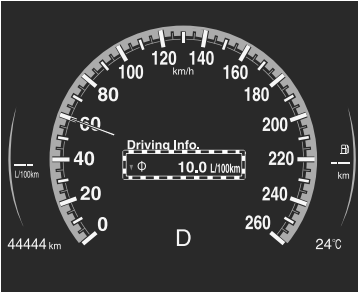

How to Use the Average Fuel Economy Display

To reset the displayed average fuel economy data, press the INFO switch for 2 seconds or longer.

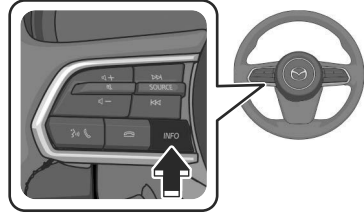

After resetting the data, - - - L/100 km (- - - mpg) is displayed until the average fuel economy is recalculated and displayed.

Instantaneous Fuel Economy Display

This displays the current fuel economy by calculating the amount of fuel consumption and the distance travelled.

(e-SKYACTIV G, e-SKYACTIV D)

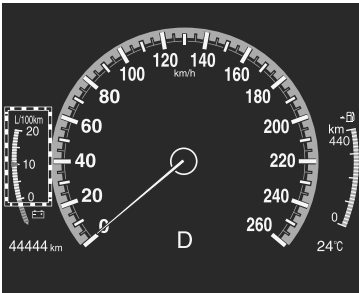

(SKYACTIV-G)

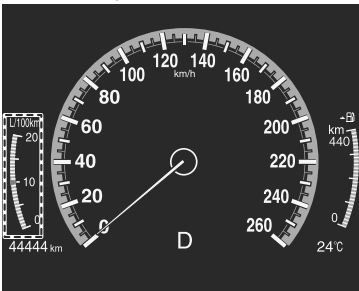

NOTE

- Displays the 0 position when the vehicle speed decreases to a constant speed or slower.
- The arrow on the scale indicates the average fuel economy.

Deceleration Regeneration Charge Display (e-SKYACTIV G, e-SKYACTIV D)

This displays the status of the charging produced by deceleration regeneration.

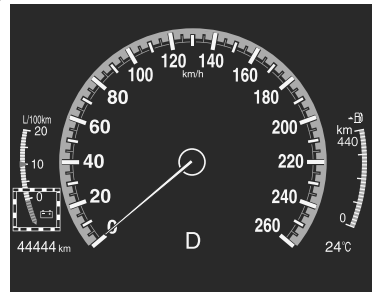

Remaining AdBlue® and Maximum Driving Distance Display*

The maximum driving distance is calculated and displayed based on the remaining amount of AdBlue®. The indication displays when the remaining amount of AdBlue® is depleted.

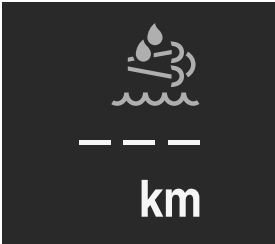

Vehicle Speed Alarm*

In this mode, the current setting for the vehicle speed alarm is displayed. You can change the vehicle speed setting at which the warning is triggered.

NOTE

The vehicle speed alarm display is activated at the same time the beep sound is heard.

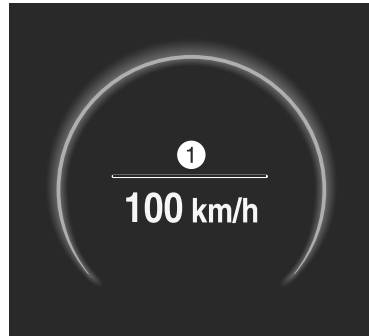

1. "Speed Alert" message is displayed

The vehicle speed alarm can be set using the centre display. Refer to the Settings section in the Mazda Connect Owner's Manual.

NOTE

Always set the vehicle speed according to the laws and regulations of the country/city in which the vehicle is driven. In addition, always verify the speed of the vehicle using the speedometer.

i-ACTIVSENSE Display

Displays the system status.

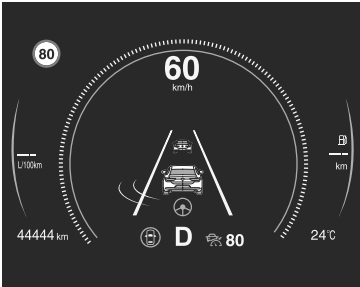

Message Display

Displays a message to notify the user of the system operation status and malfunctions or abnormalities. Follow the instructions indicated on the display. Refer to How to Use the Multi-information Display on page 5-42.

Active Driving Display*

The active driving display indicates vehicle information and navigation information.

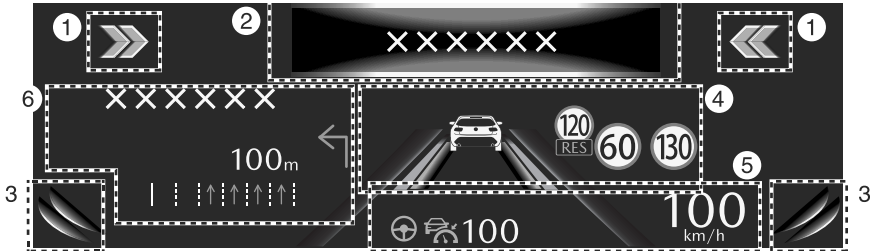

1. Front Cross Traffic Alert (FCTA) warning display area
2. Warning guidance display area
3. Blind Spot Monitoring (BSM) warning display area
4. i-ACTIVSENSE information display area
5. Vehicle speed display area and setting speed display area
6. Navigation information display area

NOTE

- Wearing polarized sunglasses will reduce the visibility of the active driving display due to the characteristics of the display.
- If the lead-acid battery has been removed and re-installed or the lead-acid battery voltage is low, the adjusted position may deviate.
- The display may be difficult to view or temporarily affected by weather conditions such as rain, snow, light, and temperature.

Warnings and Cautions for Using the Active Driving Display

WARNING

Always adjust the display brightness and position with the vehicle stopped. Adjusting the display brightness and position while driving the vehicle is dangerous as doing so could distract your attention from the road ahead and lead to an accident.

CAUTION

- Do not place beverages near the dust-proof sheet of the active driving display. If water or other liquids are splashed on the dust-proof sheet, it could cause damage.
- Do not place objects or apply stickers to the dust-proof sheet as they will cause interference.

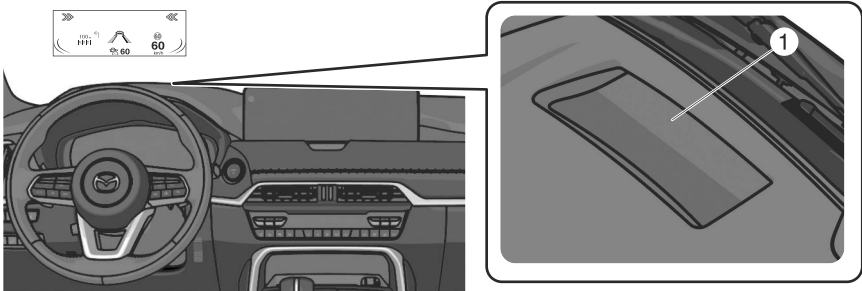

1. Dust-proof sheet

Convenient Ways to Use the Active Driving Display

The active driving display settings can be changed or adjusted. Refer to the Settings section in the Mazda Connect Owner's Manual.

NOTE

The desired driving position (display position, brightness level, display information) can be called up after programming the position. Refer to How to Use the Driving Position Memory on page 3-28.

Warning and Cautions for Using the Selector Lever

WARNING

Always apply the parking brake when the selector lever is in the P position. When parking the vehicle, only shifting the selector lever to the P position is dangerous as the vehicle may move unexpectedly and result in an accident.

Do not move the selector lever from the N or P position while the engine speed is high.

Otherwise, the vehicle will move suddenly which could lead to an unexpected accident.

When operating the selector lever, shift the selector lever with the brake pedal firmly depressed and the vehicle completely stopped.

Operating the selector lever while the vehicle is moving could lead to an unexpected accident.

Do not shift the selector lever with the accelerator pedal depressed when the selector lever is in the P or N position.

Always operate the selector lever with the brake pedal depressed when the selector lever is in the P or N position. Otherwise, the vehicle will suddenly accelerate which could lead to an accident.

Do not shift the selector lever to the N position while driving.

Otherwise, it could result in the loss of the engine braking power and cause an accident.

Do not depress the accelerator pedal unnecessarily while the vehicle is stopped.

If the accelerator pedal is mistakenly depressed when the selector lever is in a position other than the P or N position, the vehicle could suddenly accelerate resulting in an accident.

After stopping the vehicle, check the shift position indication in the instrument cluster before re-accelerating.

If the vehicle were to move unexpectedly, it could lead to an accident.

Do not allow the vehicle to move in reverse on an upslope while the selector lever is in forward drive, or move forward on a downslope while the selector lever is in reverse drive.

Otherwise, the engine could stop, making the steering wheel difficult to control, which could result in an accident.

CAUTION

- When visually checking at the rear of the vehicle while reversing the vehicle, your body twists around to the rear. Be careful and make sure that the brake pedal can be firmly depressed.
- Completely stop the vehicle before shifting the selector lever to the P position. If the selector lever is shifted to P position before the vehicle is completely stopped, unnecessary force will be applied to the transmission which could cause damage.

- On roads with high driving resistance such as deep-snowy or sandy roads, or on steep slopes, a high load is applied to the transmission, causing excessive heat generation. Under these driving conditions, pay attention to the following points.
 - Stop and hold the vehicle on a steep slope with the brake pedal, not the accelerator pedal. Do not use the accelerator pedal to prevent the vehicle from rolling.
 - Avoid using the accelerator pedal and the brake pedal at the same time.
 - Start driving the vehicle in the D or R position according to the direction of travel (avoid starting in manual mode).

If you do not follow the above precautions, the transmission may overheat. If a message, such as transmission cooling, is displayed, it is necessary to temporarily stop the vehicle to cool the transmission.

How to Use the Selector Lever

Operating the Selector Lever

1. Start the engine.
2. Operate the selector lever.

Selector lever operation	Operation condition
Shift from P position to R position	Depress the brake pedal and press the selector lever button to operate.
Shift from R position to N position	Shift the lever without pressing the selector lever button.
Shift from N position to D position	
Shift from D position to N position	
Shift from N position to R position	Press the selector lever button to shift the lever.
Shift from R position to P position	

The shift indicator turns on at the same position as the shift position displayed in the instrument cluster.

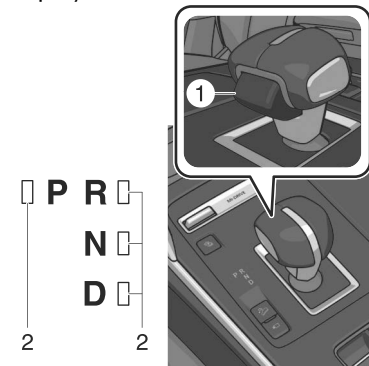

1. Selector lever button
 2. Shift indicator
- The shift position is displayed in the instrument cluster.

P

In the following cases, the shift position is displayed in the instrument cluster even if the vehicle power is in a position other than ON.

- The AUTO P (parking lock) function is operating.
- Neutral hold mode is operating.

When the shift position and the selector lever position differ, the shift position and the selector lever position are displayed.



1. Selector lever position
2. Shift position

NOTE

- If the selector lever cannot be shifted from the P position, the lead-acid battery could be depleted.

- When the selector lever is shifted from the N position to the D/R position without depressing the brake pedal, the shift position and the selector lever position differ, however, the shift guide indication is not displayed.
- When the vehicle power is switched from ON to ACC or OFF, the shift guide indication displayed after operating the AUTO P (parking lock) function turns on for a certain period of time and then it turns off.

Operating the AUTO P (Parking Lock) Function

Meet the following conditions while the vehicle is stopped.

- Switch the vehicle power from ON to OFF.
- Unfasten the driver's seat belt and open the driver's door while the shift position is in the D/R position.

The AUTO P (parking lock) function operates and the shift position automatically changes to P.

NOTE

When the AUTO P (parking lock) function operates, only the transmission shift position changes to the P position automatically. The shift position indication in the instrument cluster will differ from the selector lever position because the selector lever position does not change. Check the shift position indication in the instrument cluster and shift the selector lever to the P position.

Using Neutral Hold Mode

When in neutral hold mode, a condition is maintained for about 25 minutes in which the vehicle power is switched to ACC, the shift position is in the N position, and the parking brake is released. Use this mode when it is necessary to release the parking brake and change the shift position to the N position, such as in an automatic car wash that moves the vehicle by placing the front and rear tyres on one side of the vehicle on a belt conveyor.

Neutral Hold Mode activation method 1

1. Start the engine.
2. Release the parking brake.
3. Shift the selector lever to the N position.
4. Turn off the AUTOHOLD.
5. Press the electric parking brake (EPB) switch continuously until a sound is activated.
6. Press the push button start immediately after the sound is activated.
Neutral hold mode operates.

Neutral Hold Mode activation method 2

1. Start the engine.
2. Release the parking brake.
3. Shift the selector lever to the N position.
4. Turn off the AUTOHOLD.
5. Press the push button start while pressing the electric parking brake (EPB) switch.
Neutral hold mode operates.

Cancelling Neutral Hold Mode

If any of the following operations is performed, neutral hold mode is cancelled.

- Switch the vehicle power ON.
- Shift the selector lever to the P position.

NOTE

Neutral hold mode is cancelled automatically after about 25 minutes have passed since it was operated, and the vehicle power is switched OFF. At this time, the AUTO P (parking lock) function operates and the shift position changes to the P position.

Warnings and Cautions for Using the Steering Shift Switches

WARNING

Avoid using sudden engine braking (shift-down).

If you apply sudden engine braking (shift-down) while driving at high speed or on wet roads, snow-covered roads, or icy roads, the tyres may slip and cause an unexpected accident.

How to Use the Steering Shift Switches

Using Direct Mode

Pull the up switch (+/OFF) or the down switch (-) of the steering shift switches toward you when the selector lever is in the D position.

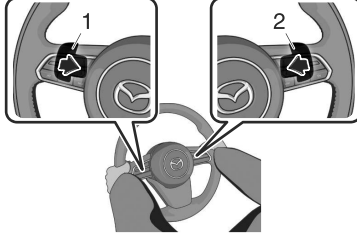

1. Down switch (-)
2. Up switch (+/OFF)

The gear position can be temporarily switched manually in direct mode.

The direct mode indication and the gear position are displayed in the instrument cluster.

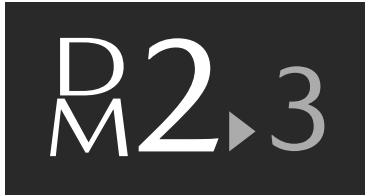

Shifting up/down

Pull the up switch (+/OFF) or the down switch (-) of the steering shift switches toward you.

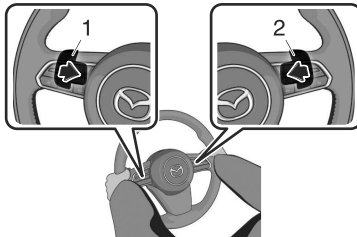

1. Down switch (-)
 2. Up switch (+/OFF)
- Shifts up or down.

NOTE

- If the automatic transmission fluid (ATF) temperature becomes too high, the mode will not switch to direct mode. In addition, if the ATF temperature becomes too high while in direct mode, the mode may be cancelled. If the mode is switched to direct mode again, it is necessary to operate the steering shift switches.
- While the vehicle is stopped, direct mode cannot be set even if the DOWN switch (-) is pulled.
- When fully depressing the accelerator pedal even while in direct mode, the transmission kicks down, but it does not kick down while the Traction Control System (TCS) is turned off. However, if the vehicle is continuously driven at a high rpm, the gears may automatically shift up to protect the engine.
- **(e-SKYACTIV G, e-SKYACTIV D)**
 - When the vehicle is driven at low speed or decelerating quickly during EV driving, the mode may not be able to be switched to direct mode using the UP switch (+/OFF) of the steering shift switches.
 - If NORMAL mode is in use while the motor is running, operating the steering shift switches will start the engine.

Cancelling Direct Mode

Direct mode can be cancelled by performing the following operations.

- The UP switch (+/OFF) is pulled toward you for a certain period of time or longer.
- The vehicle is driven for a certain period of time or longer (time differs depending on the driving conditions while operating).
- The vehicle is stopped.
- The vehicle is driven at a low speed.

Using Manual Shift Mode*

1. Select manual shift mode (M) from AT shift modes under Settings in Mazda Connect.
2. Pull the up switch (+/OFF) or the down switch (-) of the steering shift switches toward you when the selector lever is in the D position.

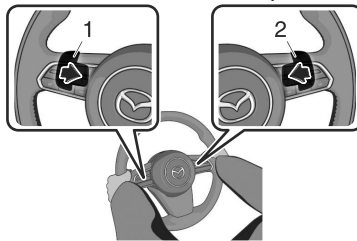

1. Down switch (-)

2. Up switch (+/OFF)

The gear position can be switched manually in manual shift mode.
The Gear Shift Indicator (GSI) is displayed in the instrument cluster.

Refer to Gear Shift Indicator (GSI) on page 5-65.

Shifting up/down

Pull the up switch (+/OFF) or the down switch (-) of the steering shift switches toward you.

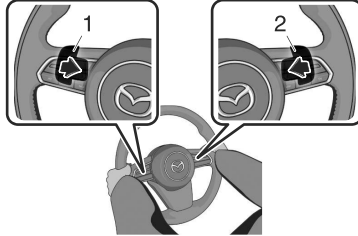

1. Down switch (-)
 2. Up switch (+/OFF)
- Shifts up or down.

NOTE

- If the automatic transmission fluid (ATF) temperature becomes too high, the mode will not switch to manual shift mode. In addition, if the ATF temperature becomes too high while in manual shift mode, the mode may be cancelled. If the mode is switched to manual shift mode again, it is necessary to operate the steering shift switches.
- When fully depressing the accelerator pedal even while in manual mode, the transmission kicks down, but it does not kick down while the Traction Control System (TCS) is turned off. However, if the vehicle is continuously driven at a high rpm, the gears may automatically shift up to protect the engine.
- (e-SKYACTIV G, e-SKYACTIV D)
 - When the vehicle is driven at low speed or decelerating quickly during EV driving, the mode may not be able to be switched to manual shift mode using the UP switch (+/OFF) of the steering shift switches.
 - If NORMAL mode is in use while the motor is running, operating the steering shift switches will start the engine.

Cancelling Manual Shift Mode

The UP switch (+/OFF) of the steering shift switches is pulled and held for a certain period of time or longer.

Manual shift mode is cancelled.

Shift gear (shifting) speed limit

The gear is shifted when the steering shift switches are operated within the speed limit ranges.

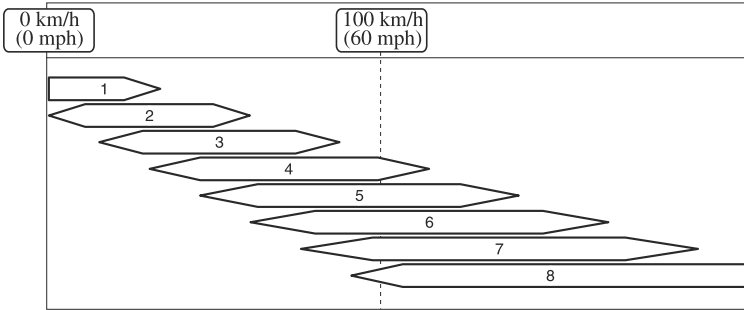

1. 1st gear
2. 2nd gear
3. 3rd gear
4. 4th gear
5. 5th gear
6. 6th gear
7. 7th gear
8. 8th gear

When shifting down is not possible depending on the vehicle speed, the gear position indication displayed in the instrument cluster flashes 2 times.

Using Second Gear Fixed Mode

Changing to second gear fixed mode facilitates accelerating from a stop and driving on slippery roads such as snow-covered roads.

The UP switch (+/OFF) of the steering shift switches is pulled while driving the vehicle at about 10 km/h (6.2 mph) or slower.

Second gear fixed mode is activated.

NOTE

When using second gear fixed mode, the vehicle stops at the 2 gear position.

Cancelling Second Gear Fixed Mode

Second gear fixed mode can be cancelled by performing the following operations.

- Pull the UP switch (+/OFF) of the steering shift switches toward you and shift into a gear other than second gear.
- Drive the vehicle at a speed of about 30 km/h (18 mph) or faster.

Convenient Ways to Use the Steering Shift Switches

You can select AT shift mode under Settings in Mazda Connect.

- Direct mode (DM)
- Manual shift mode (M)

Refer to the Mazda Connect Owner's Manual or consult an expert repairer (we recommend an Authorised Mazda Repairer).

When the vehicle power is switched OFF with manual shift mode (M) selected, the AT shift mode setting switches automatically to direct mode (DM) the next time the vehicle power is switched ON.

Gear Shift Indicator (GSI)*

The GSI supports you to obtain optimum fuel economy and smooth driving. The current gear position and the recommended gear position corresponding to the driving condition is displayed in the instrument cluster.

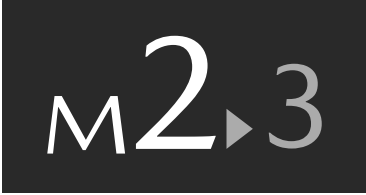

NOTE

The GSI does not display under the following conditions.

- The vehicle is stopped.
- The manual shift mode is not used.

Warning and Cautions for Using the Gear Shift Indicator (GSI)

CAUTION

Do not rely completely on the GSI. The actual driving situation might require shift operations different from the indication. To avoid the risk of accidents, the road and traffic conditions have to be determined correctly by the driver before shifting.

Warning and Cautions for Using the Foot Brake

WARNING

Do not coast with the engine turned off, find a safe place to stop.

Coasting with the engine turned off is dangerous. Braking will require more effort, and the brake's power-assist could be depleted if you pump the brake. This will cause longer stopping distances or even an accident.

Shift to a lower gear when going down steep hills.

Driving with your foot continuously on the brake pedal or steadily applying the brakes for long distances is dangerous. This causes overheated brakes, resulting in longer stopping distances or even total brake failure. This could cause loss of vehicle control and a serious accident. Avoid continuous application of the brakes.

Dry off brakes that have become wet by driving slowly, releasing the accelerator pedal and lightly applying the brakes several times until the brake performance returns to normal.

Driving with wet brakes is dangerous. Increased stopping distance or the vehicle pulling to one side when braking could result in a serious accident. Light braking will indicate whether the brakes have been affected.

Do not drive with worn disc pads.

Driving with worn disc pads is dangerous. The brakes could fail and cause a serious accident. As soon as you hear a screeching noise consult an expert repairer (we recommend an Authorised Mazda Repairer).

CAUTION

- Do not drive with your foot held on the brake pedal. Doing so could result in the following:
 - The brake parts will wear out more quickly.
 - The brakes can overheat and adversely affect brake performance.
- Always depress the brake pedal with the right foot. Applying the brakes with the unaccustomed left foot could slow your reaction time to an emergency situation resulting in insufficient braking operation.

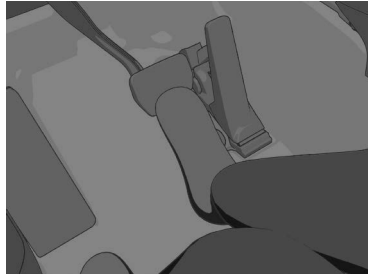

- Wear shoes appropriate for driving in order to avoid your shoe contacting the brake pedal when depressing the accelerator pedal.

Electric Parking Brake (EPB)

The EPB system applies the parking brake using a motor.

NOTE

If the parking brake is applied with the vehicle power switched to OFF or ACC, the EPB indicator light (P) in the instrument cluster and the indicator light in the switch may turn on for a certain period of time.

Warning and Cautions for Using the Electric Parking Brake (EPB)

WARNING

Do not drive the vehicle with the parking brake applied.

If the vehicle is driven with the parking brake applied, the brake parts may generate heat and the brake system may not operate, leading to an accident. Before driving the vehicle, release the parking brake and make sure that the EPB indicator light (P) in the instrument cluster turns off.

Apply the parking brake when leaving the vehicle.

Not applying the parking brake when parking the vehicle is dangerous as the vehicle may move unexpectedly and result in an accident. Before leaving the vehicle, apply the parking brake and make sure that the EPB indicator light (P) in the instrument cluster turns on.

CAUTION

- Depress the brake pedal firmly before doing a shift operation as the vehicle may start moving unexpectedly.
- If something such as the driver's foot contacts the accelerator pedal while the engine is operating and the parking brake is applied, the parking brake may be released automatically and the vehicle may move unexpectedly. If you do not intend to start driving the vehicle immediately, shift the selector lever to the P or N position.

How to Use the Electric Parking Brake (EPB)

Applying the Parking Brake Manually

1. Depress the brake pedal.
- 2.

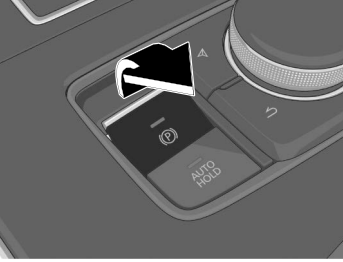

The parking brake is applied and the EPB indicator light (P) in the instrument cluster and the EPB switch indicator light turn on.

Releasing the Parking Brake Manually

1. Depress the brake pedal with the vehicle power switched ON or the engine operating.
- 2.

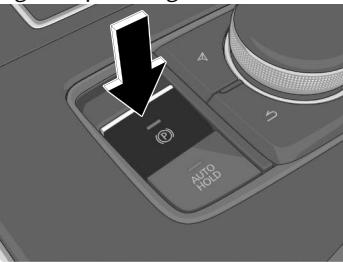

When the parking brake is released, the EPB indicator light (P) in the instrument cluster and the EPB switch indicator light turn off.

NOTE

- To release the parking brake when the vehicle power is switched OFF, it is necessary to cancel the parking brake auto operation. If the parking brake is likely to freeze such as during cold weather conditions, cancel the parking brake auto operation.
- When the charging system warning light in the instrument cluster turns on, the parking brake cannot be applied after the vehicle power is switched OFF. Before switching the vehicle power OFF, apply the parking brake manually.

Applying the Parking Brake Automatically

Switch the vehicle power from ON to ACC or OFF.

The parking brake is applied and the EPB indicator light (P) in the instrument cluster and the EPB switch indicator light turn on.

Releasing the Parking Brake Automatically

Shift-linked release

Shift the selector lever from the P position to a position other than P when all of the following conditions are met.

- Engine is operating.
- Driver's door is closed.
- Brake pedal is firmly depressed.

When the parking brake is released, the EPB indicator light (P) in the instrument cluster and the EPB switch indicator light turn off.

Accelerator-linked release

Depress the accelerator pedal when all of the following conditions are met.

- Engine is operating.
- Driver's door is closed.
- Driver's seat belt is fastened.
- The selector lever is in the D or R position.

When the parking brake is released, the EPB indicator light (P) in the instrument cluster and the EPB switch indicator light turn off.

Convenient Ways to Use the Electric Parking Brake (EPB)

Enabling/Disabling Shift-Linked Release

1. Switch the vehicle power ON.
2. Make sure that the parking brake is applied (EPB indicator light (P) is turned on).
3. Continue pulling the EPB switch for 4 seconds or longer.

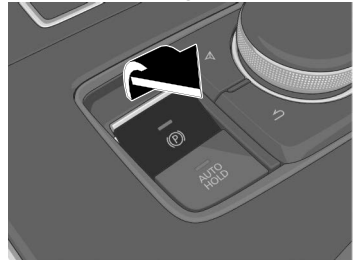

4. Release the EPB switch once.
5. Immediately continue pulling the EPB switch for 4 seconds or longer.

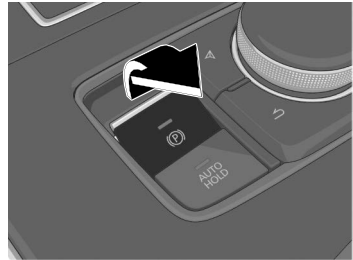

When the shift-linked release is enabled, a sound is activated 2 times, the EPB switch indicator light switches to fast flashing, and then flashes for a certain period of time. When the shift-linked release is disabled, a sound is activated 1 time, the EPB switch indicator light switches to slow flashing, and then flashes for a certain period of time.

Cancelling the Parking Brake Automatic Operation

The parking brake automatic operation returns to automatic operation when the vehicle power is switched ON. When cancelling the parking brake automatic operation and parking the vehicle, shift the selector lever to the P position and use wheel blocks on the tyres. If one of the following operations is performed, the parking brake automatic operation can be cancelled when the vehicle power is switched from ON to OFF.

Operation method 1

1. Switch the vehicle power ON.
2. Release the parking brake manually.
3. Turn off the AUTOHOLD.
4. Press the EPB switch continuously until a sound is activated.

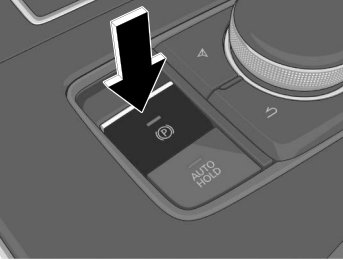

5. Release the EPB switch.
6. Switch the vehicle power OFF immediately after a sound is activated.

After the parking brake auto operation is cancelled, a warning sound is activated one time, and the EPB switch indicator light switches from illumination to flashing, and then turns off after a certain period of time has passed.

Operation method 2

1. Switch the vehicle power ON.
2. Release the parking brake manually.

3. Turn off the AUTOHOLD.
4. With the EPB switch pressed, switch the vehicle power OFF without depressing the brake pedal.

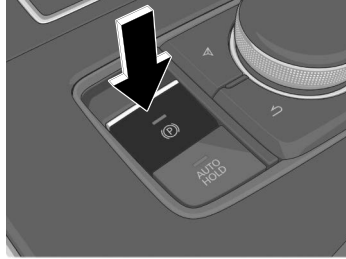

After the parking brake auto operation is cancelled, a warning sound is activated one time, and the EPB switch indicator light switches from illumination to flashing, and then turns off after a certain period of time has passed.

NOTE

- The auto operation may not cancel if the vehicle is parked on a steep slope.
- When using an automatic car wash which moves the vehicle with the front tyres mounted, it is necessary to cancel the parking brake automatic operation.

Brake Override System

The brake override system applies the brake first for safety if the brake pedal and the accelerator pedal are depressed at the same time.

Warning and Cautions for Using the Brake Override System

 **CAUTION**

Do not drive with your foot held on the brake pedal. The brake override system may not operate normally.

How to Use the Brake Override System

You can use the Mazda Connect setting to disable the brake override system warning.

Refer to the Mazda Connect Owner's Manual or consult an expert repairer (we recommend an Authorised Mazda Repairer).

AUTOHOLD

AUTOHOLD is a function to keep the vehicle stopped by applying the brakes even if you take your foot off the brake pedal while the vehicle is stopped. This function reduces the burden on the driver while the vehicle is stopped, such as at traffic lights.

Warning and Cautions for Using the AUTOHOLD

WARNING

Do not rely completely on the AUTOHOLD function.

The AUTOHOLD function is only designed to assist the brake operation while the vehicle is stopped. Neglecting to operate the brakes and relying only on the AUTOHOLD system is dangerous and could result in an unexpected accident if the vehicle were to suddenly move. Operate the brakes appropriately in accordance with the road and surrounding conditions. Note that the vehicle may move suddenly depending on the vehicle's load or if it is towing something.

Do not release your foot from the brake pedal while the vehicle is stopped on a steep grade.

Because there is a possibility of the vehicle not being held in the stopped position by the AUTOHOLD function, the vehicle may move unexpectedly and result in an accident.

Refrain from using the AUTOHOLD function on slippery roads such as icy or snow-covered roads, or unpaved roads.

Even if the vehicle is held in the stopped position by the AUTOHOLD function, the vehicle may move unexpectedly and result in an accident. Operate the accelerator pedal, brakes, or steering wheel appropriately as necessary.

Immediately depress the brake pedal in the following case.

Because the AUTOHOLD function is cancelled forcibly, the vehicle may move unexpectedly and result in an accident.

- The message “Depress Brake Pedal. Brake Hold Disabled” is displayed on the instrument cluster and the warning sound is activated at the same time.

When parking and before leaving the vehicle, apply the parking brake.

Otherwise, the vehicle may move unexpectedly and result in an accident. When parking and before leaving the vehicle, shift the selector lever to the P position and apply the parking brake.



If you stop operating the accelerator pedal before the vehicle starts driving, the force holding the vehicle in the stopped position may weaken. Firmly depress the brake pedal or depress the accelerator pedal to start driving the vehicle.

How to Use the AUTOHOLD

Operating the AUTOHOLD

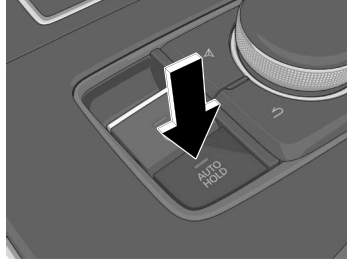

The AUTOHOLD becomes operational and the AUTOHOLD standby indicator light turns on.

Using the AUTOHOLD

1. Stop the vehicle.
When all of the following conditions are met, the AUTOHOLD operates and the AUTOHOLD active indicator light **HOLD** in the instrument cluster turns on.
 - The engine is operating.
 - The driver's seat belt is fastened.
 - The driver's door is closed.
 - The parking brake is released.
2. Start driving the vehicle.
The brakes are released and the AUTOHOLD active indicator light **HOLD** in the instrument cluster turns off.

NOTE

- When about 10 minutes or longer have passed since the AUTOHOLD operated, the parking brake is applied automatically. When the parking brake is released, the AUTOHOLD operates again.

- When the vehicle power is switched OFF while the AUTOHOLD is operating, the parking brake is applied automatically.
- If the selector lever is shifted to the R position with the vehicle tilted rearward or on level ground, the AUTOHOLD is cancelled. Operate the brakes if necessary.
- Under the following conditions, the parking brake is automatically applied and the AUTOHOLD is released. The AUTOHOLD is re-enabled when the conditions before the AUTOHOLD is released are restored.
 - The driver's seat belt is unfastened.
 - The driver's door is opened.

Cancelling the AUTOHOLD Operation

1. Depress the brake pedal with the AUTOHOLD operating.
- 2.

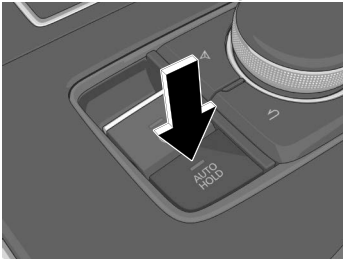

The AUTOHOLD operation is cancelled and the AUTOHOLD standby indicator light turns off.

NOTE

- The AUTOHOLD can be turned off by pressing the AUTOHOLD switch while driving.
- When the vehicle power is switched OFF while the AUTOHOLD is operating, the parking brake is applied automatically and the AUTOHOLD is turned off.

Hill Launch Assist (HLA)

The HLA prevents the vehicle from rolling backward or forward, such as when releasing the brake pedal while on a slope.

NOTE

- The HLA may not operate on a gentle slope or depending on the vehicle's load.
- The HLA does not operate if the parking brake is applied or the vehicle has not stopped completely.
- When the TCS/DSC operation indicator light  turns on, the HLA may not operate.
- The HLA does not turn off even if the TCS is turned off.

Warning and Cautions for Using the Hill Launch Assist (HLA)

WARNING

Do not rely completely on the HLA.

The HLA is designed only to assist the driver in accelerating from a stop on a slope. The HLA only operates for about 2 seconds and therefore, if the accelerator and brake pedals are not operated correctly the vehicle may move (roll) unexpectedly and cause an accident. Always confirm the safety around the vehicle before starting to drive the vehicle. Note that the vehicle may move suddenly depending on the vehicle's load or if it is towing something.

Emergency Signal System (ESS)

If sudden braking is applied, the ESS rapidly flashes all the direction indicator lights to caution drivers behind your vehicle of the sudden braking situation. The ESS operates when sudden braking is applied while the vehicle speed is 55 km/h (34 mph) or faster.

NOTE

- When you bring your vehicle to a complete stop while all the direction indicator lights are flashing rapidly, the rapid flashing of all the direction indicator lights changes back to the normal flashing pattern. The direction indicator lights turn off when you release your foot from the brake pedal.
- When the ABS operates, the ESS is more likely to operate. Therefore, if the brakes are applied on a slippery road, the ESS may operate.

Light Switch

Each light turns on/off when the switch is operated.

With Auto Light

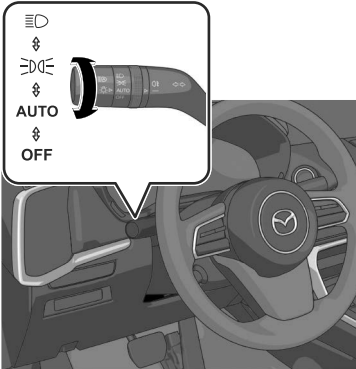

Without Auto Light

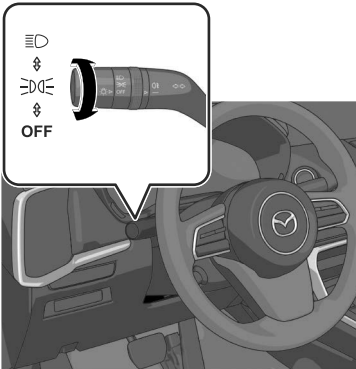

Warnings and Cautions for Using the Light Switch

CAUTION

Do not cover the light sensor by applying stickers or labels to the windscreen. Otherwise the sensor cannot detect the surrounding light correctly.

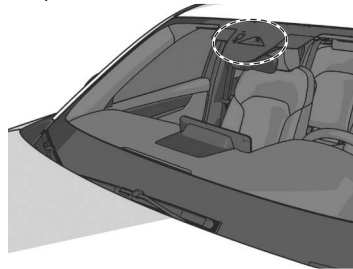

How to Use the Light Switch

NOTE

Headlights which do not blind drivers approaching in the opposite direction have been adopted. Therefore, it is not necessary to adjust the optical axis of the headlights even when travelling temporarily in a country where vehicles are driven on the right-hand side of the road.

Using the Lights Automatically

Using the Auto Light*

Make sure that the light switch is in the AUTO position.

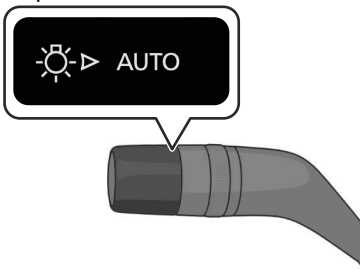

The daytime running lights turn on automatically when it is bright, and the headlights, position lights, tail lights, and the number plate lights turn on automatically when it is dark.

When the position lights, tail lights, and the number plate lights are turned on, the position lights indicator light  in the instrument cluster turns on.

NOTE

- If the surroundings remain dark for several minutes even during daytime, the light sensor determines that it is nighttime, and the lights may not turn off immediately even if the surroundings become bright.

- The illumination timing for the headlights can be changed. Refer to the Mazda Connect Owner's Manual or consult an expert repairer (we recommend an Authorised Mazda Repairer).

Using the Daytime Running Lights*

The daytime running lights turn on while driving in bright surroundings such as during the day.

NOTE

(Only in regions where daytime running lights are not mandatory)

The daytime running lights can be set so that they do not to turn on. Refer to the Mazda Connect Owner's Manual or consult an expert repairer (we recommend an Authorised Mazda Repairer).

Using the Lights Manually

Using the Position lights, Tail lights, and Number Plate Lights

(The vehicle power is switched to ON)

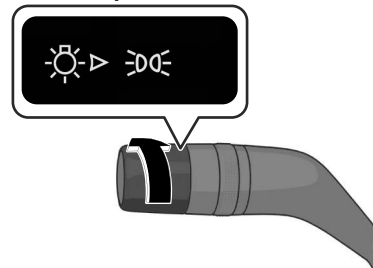

The position lights, tail lights, and number plate lights turn on, and the position lights indicator light  in the instrument cluster turns on. When the vehicle power is switched OFF while the position lights, tail lights, and the number plate lights are turned on, the position lights, tail lights, and the number plate lights turn off.

(The vehicle power is switched to ACC or OFF)

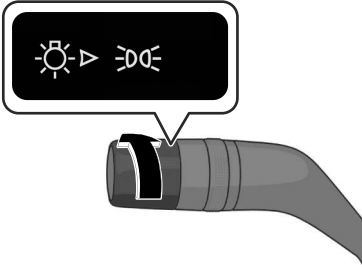



The position lights, tail lights, and number plate lights turn on, and the position lights indicator light  in the instrument cluster turns on.

NOTE

Do not leave the lights on while the engine is turned off. Otherwise, the lead-acid battery power could be depleted.

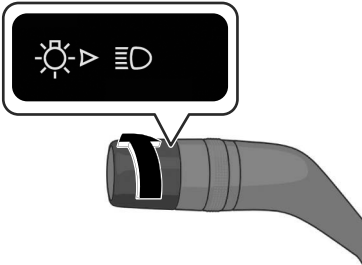
Using the Headlights



The headlights, position lights, tail lights, and the number plate lights turn on, and the position lights indicator light  in the instrument cluster turns on.

Switching the Headlights to High Beams

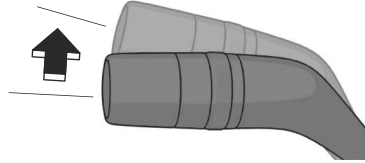

The headlights are switched to high beams and the headlight high-beam indicator light  in the instrument cluster turns on.

When the lever is returned to its original position, the headlights are switched to low beams.

Flash-to-pass

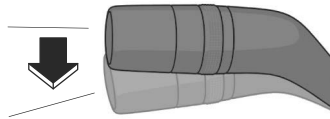

While the lever is being operated, the headlight high beams turn on and the headlight high-beam indicator light  in the instrument cluster turns on.

Turning off the Lights

Turn the light switch to the **OFF** position when the vehicle is stopped.

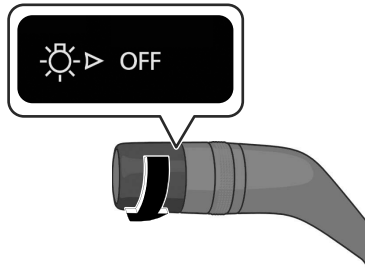

(With Auto Light)

The light switch returns to the **AUTO** position automatically.

All the lights that are turned on turn off, and the position lights indicator light  in the instrument cluster turns off.

Headlight Levelling

The number of passengers and weight of cargo in the luggage compartment change the angle of the headlights. The angle of the headlights will be automatically adjusted when turning on the headlights. A system malfunction or operation conditions are indicated by a warning. Refer to Exterior Lights Warning Light on page 8-53.

Convenient Ways to Use the Light Switch

Coming Home Light

After the vehicle power is switched OFF, the headlights can be turned on for a while.

Using the coming home light

1. Switch the vehicle power to ACC or OFF.

2.

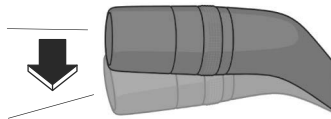

The headlights turn on, and then turn off when any of the following conditions is met.

- A certain amount of time has passed since occupants got out of the vehicle and all the doors closed.
- Three minutes have passed since the headlights turned on.
- The light switch was operated after the headlights turned on.

NOTE

The time until the headlights turn off can be changed.

Refer to the Mazda Connect Owner's Manual or consult an expert repairer (we recommend an Authorised Mazda Repairer).

Leaving Home Light

The lights of your vehicle parked at a distance can be turned on by operating the key.

Using the leaving home light

Press the unlock button on the key while the vehicle power is switched OFF.

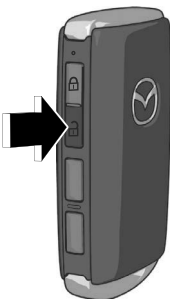

When the vehicle receives a key operation signal, the headlights, position lights, tail lights, and the number plate lights turn on. The lights turn off when any of the following conditions is met.

- Thirty seconds have passed since the lights turned on.
- The light switch is set to the **OFF** position.
- The lock button on the key is pressed.

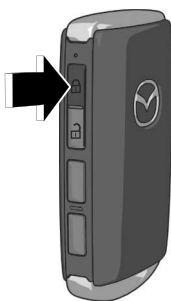

NOTE

The leaving home light can be set so that it does not to operate. Refer to the Mazda Connect Owner's Manual or consult an expert repairer (we recommend an Authorised Mazda Repairer).

How to Use the Fog Light Switch*

When the switch is operated, the rear fog light turns on/off.

Using the Rear Fog Light

When the headlights are turned on, turn the rear fog light switch to the  position.

The fog light switch automatically returns to the - position.

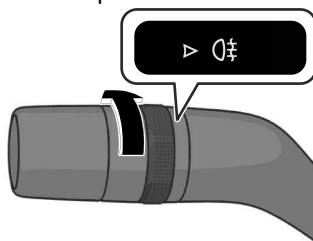

The rear fog light turns on and the rear fog light indicator light  in the instrument cluster turns on.

NOTE

Even if the headlights are turned off, the rear fog light remains on when the position lights are on.

Turning off the Rear Fog Light

Turn the rear fog light switch to the  position or the light switch to the **OFF** position.

How to Use the Direction Indicator Lever

When the lever is operated, the direction indicator lights flash/turn off.

Using the Direction Indicator Lever

Turning left or right

Operate the lever to the 1 or 4 position.

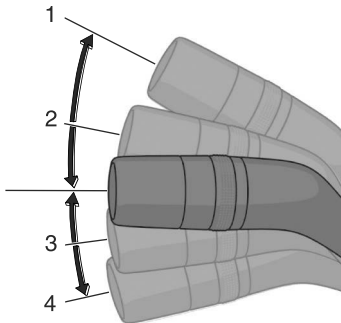

Each direction indicator light flashes and the direction indicator light  in the instrument cluster flashes. The lever returns to its original position in conjunction with the steering wheel operation. If it does not return, return it by hand.

Changing lanes

Operate the lever to the 2 or 3 position.

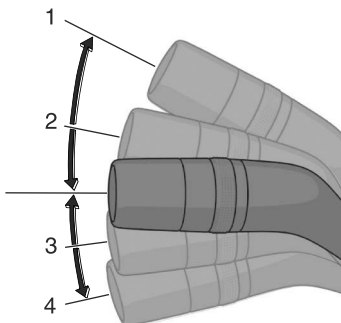

While the lever is in the 2 or 3 position, each direction indicator light flashes and the direction indicator light  in the instrument cluster flashes. If you move the lever to the 2 or 3 position and release it immediately, the three-flash turn signal operates and the direction indicator light flashes 3 times.

NOTE

- The volume of the direction indicator lever sound can be changed. Refer to the Mazda Connect Owner's Manual or consult an expert repairer (we recommend an Authorised Mazda Repairer).
- The three-flash turn signal can be turned off. Refer to the Mazda Connect Owner's Manual or consult an expert repairer (we recommend an Authorised Mazda Repairer).

Windscreen Wiper/ Washer Switch

When the switch or lever is operated, the windscreen wiper/washer operates.

With Auto-Wiper Control

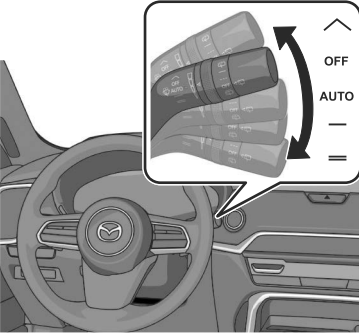

With Intermittent Wiper

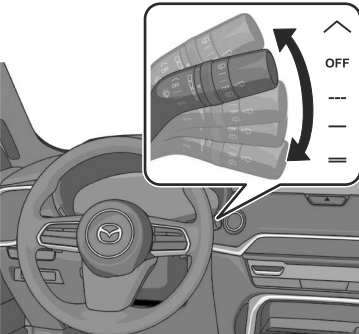

Warning and Cautions for Using the Windscreen Wiper/Washer Switch

⚠ WARNING

In cold regions, use washer fluid containing anti-freeze. In addition, warm the windscreen glass before spraying washer fluid during cold temperatures.

If washer fluid not containing anti-freeze is used during cold temperatures, it will freeze on the windscreen causing reduced visibility which may lead to an accident. Before spraying washer fluid, use the defroster to make sure that the windscreen is sufficiently warmed up.

⚠ CAUTION

- When the windscreen wipers are not used during freezing temperatures or for a long time, the wiper rubber may freeze to the glass. If the wipers are operated while frozen to the glass, it could damage the wiper rubber and motor.
- If the windscreen wipers are operated while the windscreen glass is dry, the glass could be scratched and the wiper rubber damaged. When the window glass is dry, spray washer fluid before operating the wipers.
- If the amount of washer fluid spray is insufficient, do not use the windscreen washer switch. If the washer switch continues to be operated with no washer fluid being sprayed, it could lead to pump damage.

Windscreen Wiper/Washer Switch

- Do not cover the rain sensor by applying stickers or labels to the windscreen. Otherwise, the sensor cannot detect the amount of rainfall.

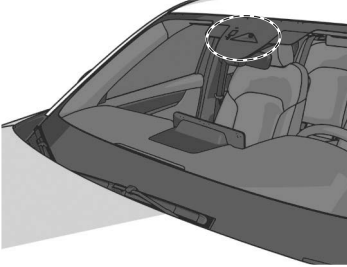

- When the vehicle power is switched ON and the wiper lever is in the AUTO position, the windscreen wipers may operate automatically in the following cases:
 - The area of the windscreen above the rain sensor is touched or wiped with a cloth.
 - The windscreen or the rain sensor area in the cabin is hit.

When the vehicle power is switched ON and the wiper lever is in the AUTO position, do not touch the windscreen or the windscreen wipers. Otherwise, the windscreen wipers will operate automatically which could catch your fingers or damage the windscreen wipers. When removing ice or snow, or cleaning the windscreen, always make sure the wiper lever is in the OFF position.

How to Use the Windscreen Wiper/Washer Switch

Using the Auto Wipers*

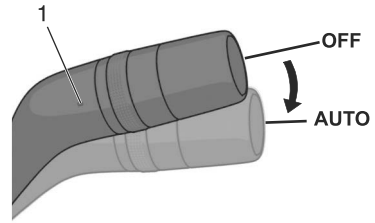

1. Indicator light

The indicator light of the lever turns on. The windscreen wipers operate automatically according to the rainfall amount.

CAUTION

Even if it is not raining, the windscreen wipers may operate automatically in the following cases.

- The area of the windscreen above the rain sensor is touched or wiped with a cloth.
- The windscreen or the rain sensor area in the cabin is hit.

NOTE

- If a water repellent coating other than a genuine product is used, the rain sensor may not detect the rainfall amount correctly and the auto wipers may not operate normally. Do not use a water repellent coating other than a genuine product.

Windscreen Wiper/Washer Switch

- If dirt or ice adheres to the top of the rain sensor on the windscreen and the windscreen wipers cannot remove the dirt or ice even after the wipers operate several times, the auto wipers will stop operating. If the auto wipers stopped, remove the dirt and ice from the windscreen.
- The auto wipers could operate from the effect of strong light sources, electromagnetic waves, or infrared light because the rain sensor uses an optical sensor. It is recommended that the auto-wiper lever be switched to the **OFF** position other than when driving the vehicle under rainy conditions.

Changing sensitivity of auto wipers

The rain sensitivity level can be adjusted by rotating the switch.

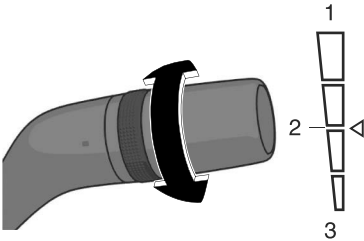

1. Higher sensitivity
2. Normal
3. Less sensitivity

Using the Intermittent Wiper*

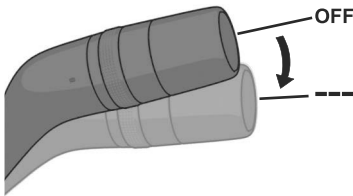

The wipers operate intermittently.

Changing the intermittent operation time

The intermittent operation time can be adjusted by turning the switch.

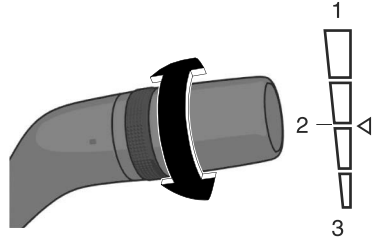

1. Fast
2. Normal
3. Slow

Using the Windscreen Wipers

Using continuously

Set the lever to the **—** or **==** position.

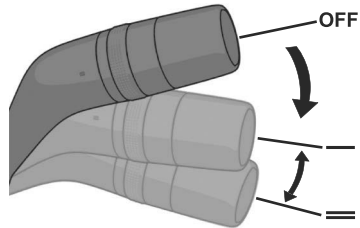



In the **—** position, the windscreen wipers operate at low speed. In the **==** position, the wipers operate at high speed.

Windscreen Wiper/Washer Switch

Using temporarily

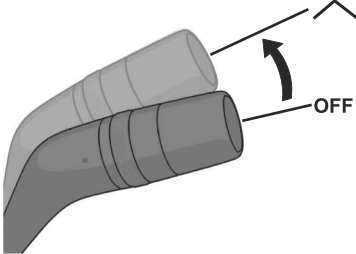
Set the lever to the  position.



The windscreen wipers operate while the lever is in the  position.

Set the lever to the  position and immediately release it to operate the windscreen wipers only once.

Stopping the Windscreen Wipers

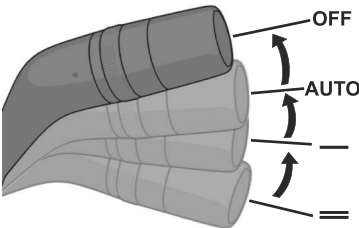

The windscreen wipers stop.

Using the Windscreen Washer

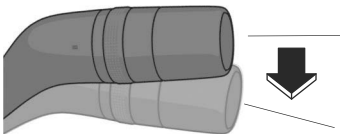

While the windscreen wipers move out of their stowed positions to the point where they start reversing back, the washer fluid is sprayed and the wipers operate several times.

NOTE

- When the windscreen washer is used for the first time after turning on the headlights, the headlight washers also operate in conjunction with it.
- If you pull the wiper lever while the windscreen wipers are reversing back to their stowed positions, the next time the washer fluid is sprayed is during the next cycle.

Using the Headlight Washers*

When the headlights are turned on, pull the lever 2 times in the direction of the arrow.

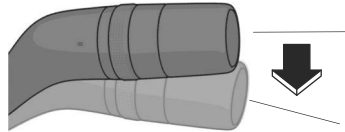

The washer fluid is sprayed.

NOTE

When the windscreen washer is used for the first time after turning on the headlights, the headlight washers also operate in conjunction with it.

How to Use the Rear Wiper/Washer Switch

Using the Rear Wiper

Using intermittent operation

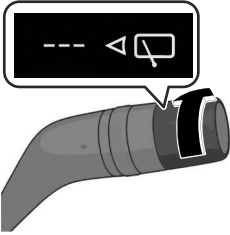

The wiper operates at regular intervals.

Using continuous operation

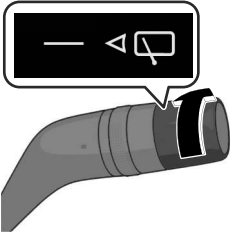

The wiper operates continuously.

Stopping the Rear Wiper

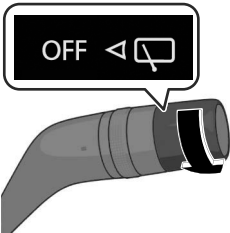

The rear wiper stops.

Using the Rear Washer

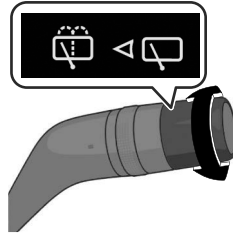

While the switch is in the  position, the washer fluid is sprayed and the wiper operates.

NOTE

When the windscreen washer fluid is being sprayed, the rear washer fluid will not be sprayed even if the switch is operated.

Rear Window Defogger Switch

The rear window defogger warms the rear window and removes fog. When the rear window defogger is operated, the following equipment operates in conjunction with it.

- Mirror defogger*
Refer to How to Use the Mirror Defogger on page 5-91.
- Windscreen wiper de-icer*
Refer to How to Use the Windscreen Wiper De-icer on page 5-92.

Warnings and Cautions for Using the Rear Window Defogger Switch

CAUTION

- Be careful not to scratch the filaments when washing the rear window. The filaments are installed inside the rear window.
- Use the rear window defogger while the engine is running. In addition, do not use the rear window defogger for a long time. Otherwise, the lead-acid battery power could be depleted.

How to Use the Rear Window Defogger Switch

Using the Rear Window Defogger Switch

1. Start the engine.
- 2.

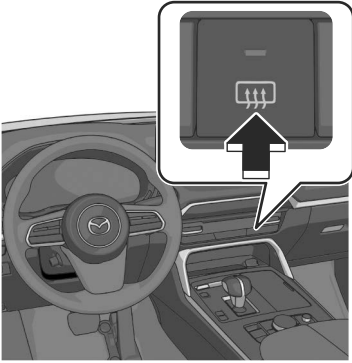

The rear window defogger operates and the switch indicator light turns on. The rear window defogger stops automatically after it operates about 15 minutes.

NOTE

The rear window defogger operation time can be changed. Refer to the Mazda Connect Owner's Manual or consult an expert repairer (we recommend an Authorised Mazda Repairer).

Stopping the Rear Window Defogger

Press the rear window defogger switch while the rear window defogger is operating. The rear window defogger stops and the switch indicator light turns off.

Mirror Defogger*

The mirrors are heated using heat filaments to remove fog.

How to Use the Mirror Defogger

The mirror defoggers operate in conjunction with the rear window defogger.

For the operation method, refer to How to Use the Rear Window Defogger on page 5-90.

Windscreen Wiper De-icer*

A part of the windscreen is heated using heat filaments to melt the ice on the glass and wipers.

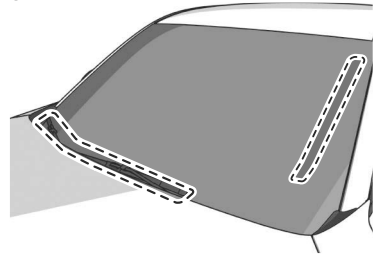

How to Use the Windscreen Wiper De-icer

The windscreen wiper de-icers operate in conjunction with the rear window defogger.

For the operation method, refer to How to Use the Rear Window Defogger on page 5-90.

Hazard Warning Lights



The hazard warning light switch is used when it is necessary to park the vehicle on a roadside due to a vehicle breakdown or other emergency.

How to Use the Hazard Warning Lights

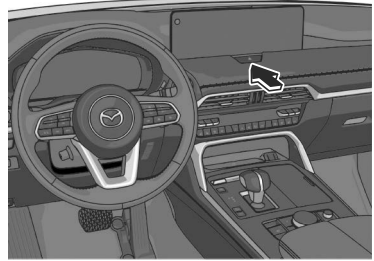
The vehicle power is switched ON



(Except European models)

All the direction indicator lights flash, and the direction indicator light  and the hazard warning light  in the instrument cluster flash.

(European models)

All the direction indicator lights flash and the direction indicator light  in the instrument cluster flashes. Press the switch again to turn off the lights.

The vehicle power is switched to ACC or OFF

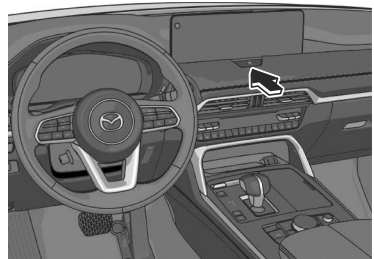

All the direction indicator lights flash and the hazard warning light  in the instrument cluster flashes. Press the switch again to turn off the lights.

How to Use the Horn

Press the area around the  mark on the steering wheel.
The horn sounds while it is pressed.

Antilock Brake System (ABS)

The ABS prevents the wheels from locking, caused by braking on slippery roads, and maintains driving directional stability and ensures steerability.

NOTE

- When depressing the brake pedal, slight vibration might be felt from the pedal. This vibration is a normal occurrence when the ABS operates.
- ABS does not operate at low speeds (about 10 km/h (6.2 mph) or slower).

Warning and Cautions for Using the Antilock Brake System (ABS)

WARNING

Do not rely on the ABS as a substitute for safe driving.

The ABS cannot compensate for unsafe and reckless driving, excessive speed, tailgating (following another vehicle too closely), driving on ice and snow, and hydroplaning (reduced tyre friction and road contact because of water on the road surface). You can still have an accident.

CAUTION

Always use tyres of the specified size and type for the front and rear wheels. If a tyre other than the specified size or type is installed, the ABS system may not operate normally.

Traction Control System (TCS)

The TCS prevents drive-wheel spinning which occurs during acceleration from a stop or acceleration during cornering on slippery roads, such as wet or snow-covered roads, and assures optimum drive force and steerability.

Warning and Cautions for Using the Traction Control System (TCS)

WARNING

Do not rely on the Traction Control System (TCS) as a substitute for safe driving.

The Traction Control System (TCS) cannot compensate for unsafe and reckless driving, excessive speed, tailgating (following another vehicle too closely), and hydroplaning (reduced tyre friction and road contact because of water on the road surface). You can still have an accident.

Use snow tyres or tyre chains and drive at reduced speeds when roads are covered with ice and/or snow.

Driving without proper traction devices on snow and/or ice-covered roads is dangerous. The Traction Control System (TCS) alone cannot provide adequate traction and you could still have an accident.

How to Use the Traction Control System (TCS)

Switch the vehicle power ON.
The TCS is operable.
When the TCS operates, the TCS/DSC operation indicator light  flashes.

Stopping the TCS Operation

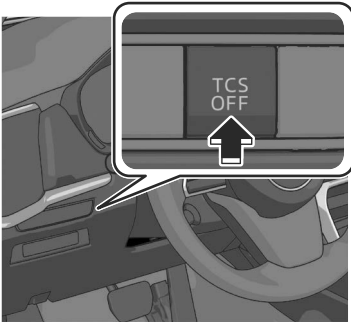

The TCS operation is cancelled and the TCS OFF indicator light ^{TCS}OFF in the instrument cluster and the TCS OFF switch indicator light turn on. Press the TCS OFF switch again to enable the TCS operation.

NOTE

- If the engine is stopped while the TCS operation is cancelled, the TCS becomes operational when the engine is started the next time.
- When the TCS is on and you attempt to free the vehicle from being stuck, the TCS will activate. Depressing the accelerator will not increase engine power and freeing the vehicle from being stuck might be difficult. When this happens, turn off the TCS.
- If the TCS is cancelled and the following systems are operated, the TCS becomes operational.
 - Smart Brake Support (SBS)

- Mazda Radar Cruise Control (MRCC)
- Cruising & Traffic Support (CTS)

Convenient Ways to Use the Traction Control System (TCS)

If the TCS OFF switch is pressed and held for 10 seconds or longer, the TCS operation can no longer be turned off even if the TCS OFF switch is pressed. In this case, the TCS OFF switch will operate normally when the vehicle power is switched ON again after being switched OFF.

Dynamic Stability Control (DSC)

The DSC automatically controls braking and engine power output in conjunction with systems such as the ABS and TCS to help control side slip when driving on slippery surfaces, or during sudden or evasive steering, which enhances vehicle stability. Also refer to Antilock Brake System (ABS) 5-95, Traction Control System (TCS) 5-96.

Warning and Cautions for Using the Dynamic Stability Control (DSC)

WARNING

Do not rely on the Dynamic Stability Control as a substitute for safe driving.

The Dynamic Stability Control (DSC) cannot compensate for unsafe and reckless driving, excessive speed, tailgating (following another vehicle too closely), and hydroplaning (reduced tyre friction and road contact because of water on the road surface). You can still have an accident.

CAUTION

- Heed the following cautions so that the DSC can operate normally.
 - Always use tyres of the specified size, same manufacturer, brand, and pattern (tread pattern) for the front and rear wheels.
 - Do not use tyres with significantly different wear patterns on the same vehicle.
 - Do not use tyres with sizes other than the specified size, different type, and significantly different wear patterns on the same vehicle.
- When using tyres where the tyre diameter is changed due to the installation of tyre chains, or when installing an emergency spare tyre, the DSC may not operate normally.

How to Use the Dynamic Stability Control (DSC)

Drive the vehicle at a speed of about 20 km/h (13 mph) or faster.

The DSC is operable.

When the DSC operates, the TCS/DSC operation indicator light  flashes.

Trailer Stability Control (TSC)

The TSC is a system that increases the stability of the vehicle during towing. When vehicle sway occurs during towing, the TSC controls the output of the brakes and the engine to suppress swaying.

Warning and Cautions for Using the Trailer Stability Control (TSC)

WARNING

Do not rely solely on the Trailer Stability Control (TSC).

Vehicle stability can be limited even if the Trailer Stability Control (TSC) is operating. Drive carefully to prevent accidents. In particular, if the TCS/DSC indicator light is flashing, drive the vehicle carefully as it is in a less stable condition and could sway more easily. Drive with caution and in accordance with the road, vehicle and trailer conditions.

CAUTION

- The Trailer Stability Control (TSC) may not operate correctly unless the following are observed:
 - Use tyres of the correct size specified for your Mazda on all four wheels.
 - Use tyres of the same manufacturer, brand and tread pattern on all four wheels.
 - Do not mix worn tyres.
- The Trailer Stability Control (TSC) may not operate correctly when tyre chains are used or a temporary spare tyre is installed because the tyre diameter changes.

How to Use the Trailer Stability Control (TSC)

Drive the vehicle at a speed of 65 km/h (40 mph) or faster.

The TSC is operable.

When the TSC operates, the TCS/DSC operation indicator light  flashes.

NOTE

- The Trailer Stability Control (TSC) does not operate if there is a malfunction in the TCS/DSC (the TCS/DSC operation indicator light  turns on).
- When the Trailer Stability Control (TSC) is operating, the brake lights may turn on.
- For information regarding trailer towing, refer to Towing on page 7-81.

Hill Descent Control*

The hill descent control is a system that maintains a constant vehicle speed when the vehicle descends a steep slope, off-road or on a snowy road. As the low speed can be maintained without operating the accelerator pedal or the brake pedal, the driver can concentrate on the steering wheel operation.

Warnings and Cautions for Using the Hill Descent Control

WARNING

Do not rely completely on the hill descent control.

If necessary, depress the brake pedal on a slippery road surface such as extremely steep slopes, icy roads, or mud or gravel roads. Failure to maintain a constant low speed may result in an unexpected accident. Always drive carefully.



How to Use the Hill Descent Control

Using the Hill Descent Control

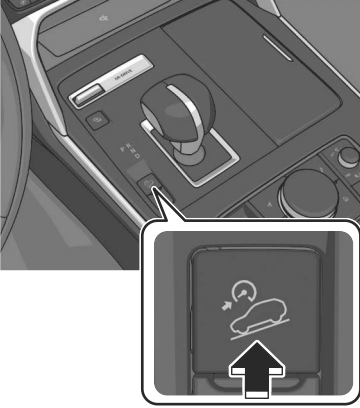
1. When the vehicle speed is about 25 km/h (15 mph) or slower, press the hill descent control switch.



The hill descent control is operable, and the hill descent control indicator light (white)  turns on.

2. Depress the accelerator pedal or the brake pedal to drive the vehicle at a speed between about 3 km/h and 20 km/h (2 and 12 mph).
3. Release the accelerator pedal or the brake pedal when the desired target speed is reached. The hill descent control operates, the hill descent control indicator light (white)  changes to the hill descent control indicator light (green) , and then the target speed is displayed.

The brake lights turn on while the hill descent control is operating.



NOTE

- If the braking system is overheated after using the hill descent control for a long time, the operation of the hill descent control may be temporarily stopped. When the operation of the hill descent control stops, a warning sound is activated and the hill descent control indicator light turns off.
- The hill descent control may not be available due to a system malfunction in the following cases. Have your vehicle inspected by an expert repairer (we recommend an Authorised Mazda Repairer).
 - The hill descent control indicator light does not turn on even if the hill descent control switch is pressed.
 - The TCS/DSC operation indicator light turns on.
- The hill descent control is not available while Mazda Radar Cruise Control (MRCC) or Cruising & Traffic Support (CTS) is operating.

Cancelling the Hill Descent Control

Perform the following operations to cancel the hill descent control.

- Press the hill descent control switch.
If the hill descent control switch is pressed while the hill descent control is operating, the hill descent control will be gradually released.
- Drive the vehicle at a vehicle speed of about 30 km/h (18 mph) or faster.

Mazda intelligent Drive Select (Mi-Drive)

Mi-Drive is a system which switches the vehicle's drive mode depending on the driving conditions, road conditions, and vehicle conditions. Mi-Drive has the following driving modes.

TOWING Mode*

This mode optimizes power performance. It reduces the loss of driving performance due to increased weight when towing a trailer and improves the vehicle stability.

SPORT Mode

This mode maximizes responsiveness. It increases vehicle response when the accelerator pedal is depressed and accelerates powerfully.

NORMAL Mode

This mode optimizes fuel efficiency.

OFF-ROAD Mode*

This mode maximizes running performance. It prevents the drive wheels from spinning during off-road driving and improves the running performance.

Warning and Cautions for Using the Mazda intelligent Drive Select (Mi-Drive)

WARNING

Do not rely completely on the Mi-Drive system.

Vehicle stability is limited even when Mi-Drive is activated. Always drive the vehicle safely. Do not drive the vehicle recklessly, otherwise it may result in an accident.

Do not use OFF-ROAD mode when driving on a paved road.

Use Off-road mode when driving on slippery roads such as muddy, sandy, or deep-snowy roads. During normal driving, use normal mode.

CAUTION

- Do not use the sport mode when driving on slippery roads such as wet or snow-covered roads. It may cause tyre slipping.
- Heed the following cautions so that the system can operate normally.
 - Always use tyres of the specified size, same manufacturer, brand, and pattern (tread pattern) for the front and rear wheels.
 - Do not use tyres with significantly different wear patterns on the same vehicle.
- Drive carefully when using tyre chains. Because the diameter of the tyres differs, the system may not operate normally.

Mazda intelligent Drive Select (Mi-Drive)

How to Use the Mazda intelligent Drive Select (Mi-Drive)

1. Push the Mi-Drive switch forward or pull it toward you.

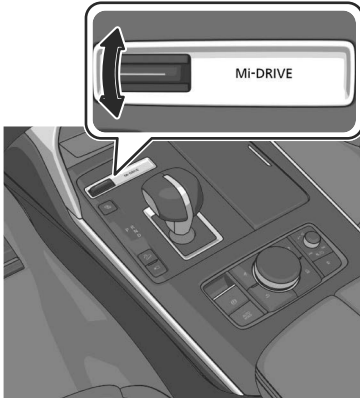

2. While checking the list displayed in the instrument cluster, push the Mi-Drive switch forward or pull it toward you to select a drive mode.

Instrument cluster (Type A)



Instrument cluster (Type B)

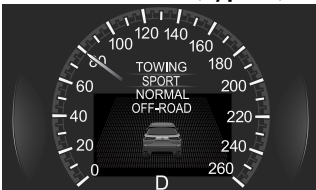

When the drive mode is set, the display in the instrument cluster changes.

(TOWING Mode)* Instrument cluster (Type A)

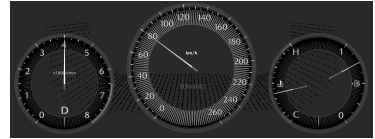

Instrument cluster (Type B)

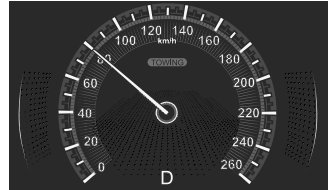

(SPORT Mode) Instrument cluster (Type A)



Instrument cluster (Type B)

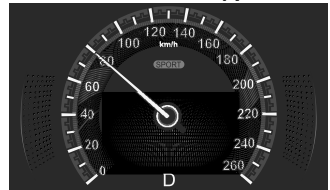

(NORMAL Mode) Instrument cluster (Type A)



Instrument cluster (Type B)

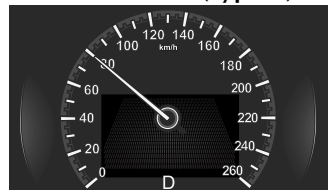

**(OFF-ROAD Mode)*
Instrument cluster (Type A)**

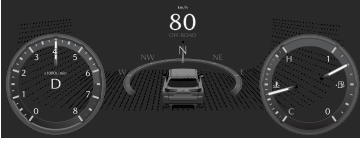

Instrument cluster (Type B)



NOTE

- TOWING mode can be selected only when electrically connected to the trailer using a Mazda genuine trailer hitch. In addition, it may take some time until the connection is detected and TOWING mode is displayed. Consult an expert repairer (we recommend an Authorised Mazda Repairer) for details.
- Depending on driving conditions when selecting TOWING mode/SPORT mode/OFF-ROAD mode, the vehicle may perform shift-down or accelerate slightly.
- When SPORT mode/OFF-ROAD mode is selected, driving the vehicle at higher engine speeds increases and fuel economy may worsen. Cancelling SPORT mode/OFF-ROAD mode during normal driving is recommended.
- When setting the Mazda Radar Cruise Control (MRCC) while driving in SPORT mode, the mode is switched to NORMAL mode. In addition, while the MRCC is being used, the mode cannot be switched to SPORT mode.

- The drive mode cannot be switched in the following cases.
 - The Antilock Brake System (ABS) is operating.
 - The Traction Control System (TCS) is operating.
 - The Dynamic Stability Control (DSC) is operating.
 - The steering wheel is being operated abruptly.
- The driving mode in which the display in the instrument cluster is grayed out cannot be selected.
- When the vehicle power is switched OFF, the mode returns to NORMAL mode. However, TOWING mode before switching the vehicle power OFF is maintained only when the trailer is connected in TOWING mode.

i-ACTIV AWD*

AWD demonstrates superior driving performance on slippery surfaces such as snow-covered roads, sandy areas, mud, and steep slopes.

Warnings and Cautions for Using the i-ACTIV AWD

WARNING

Do not rotate wheels that have left the ground due to the vehicle being stuck or in a ditch.

The drive component can be seriously damaged, resulting in an accident. It can also lead to overheating, oil leakage, and fire.

CAUTION

This vehicle is not designed for off-road and rally driving. Do not drive over rough rocky roads and river beds.

Power Steering

The power steering operates while the engine is operating.

Even when the engine is stopped or the power steering system does not operate, steering is possible but the operation may feel heavier compared to normal.

Tyre Pressure Monitoring System (TPMS)*

The TPMS monitors the air pressure of each tyre and informs the driver of a decrease in the tyre air pressure when it becomes lower than the specified air pressure.

For the TPMS, the air pressure data sent from the tyre pressure sensors installed on each wheel via radio signal is received by the receiver unit in the vehicle to monitor the tyre pressures.

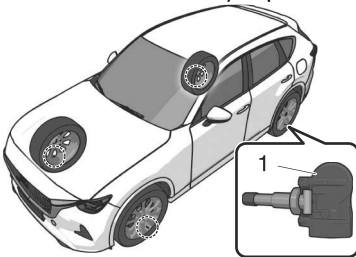

1. Tyre pressure sensor

Warning and Cautions for Using the Tyre Pressure Monitoring System (TPMS)

WARNING

Do not drive the vehicle at high speeds if the TPMS warning light  is turned on or flashing.

Driving the vehicle at high speeds while the TPMS warning light is turned on or flashing is dangerous because the brake performance and the steering wheel operability will be reduced. If the vehicle is driven at high speeds or the brakes are suddenly applied, it could lead to an accident. Gradually apply the brake and reduce the vehicle speed.

Do not ignore the TPMS warning light  when it is turned on or flashing.

Continuing to drive the vehicle while ignoring the illumination/flashing of the TPMS warning light is dangerous because a tyre may burst which could lead to an accident. Take appropriate measures as soon as possible.

CAUTION

- Each tyre, including the spare (if provided), should be checked monthly when cold and inflated to the inflation pressure recommended by the vehicle manufacturer on the vehicle placard or tyre inflation pressure label. (If your vehicle has tyres of a different size than the size indicated on the vehicle placard or tyre inflation pressure label, you should determine the proper tyre inflation pressure for those tyres.) As an added safety feature, your vehicle has been equipped with a tyre pressure monitoring system (TPMS) that illuminates a low tyre pressure telltale when one or more of your tyres is significantly under-inflated. Accordingly, when the low tyre pressure telltale illuminates, you should stop and check your tyres as soon as possible, and inflate them to the proper pressure. Driving on a significantly under-inflated tyre causes the tyre to overheat and can lead to tyre failure. Under-inflation also reduces fuel efficiency and tyre tread life, and may affect the vehicle's handling and stopping ability. Please note that the TPMS is not a substitute for proper tyre maintenance, and it is the driver's responsibility to maintain correct tyre pressure, even if under-inflation has not reached the level to trigger illumination of the TPMS low tyre pressure telltale. Your vehicle has also been equipped with a TPMS malfunction indicator to indicate when the system is not operating properly.

The TPMS malfunction indicator is combined with the low tyre pressure telltale. When the system detects a malfunction, the telltale will flash for approximately one minute and then remain continuously illuminated.

This sequence will continue upon subsequent vehicle start-ups as long as the malfunction exists. When the malfunction indicator is illuminated, the system may not be able to detect or signal low tyre pressure as intended. TPMS malfunctions may occur for a variety of reasons, including the installation of replacement or alternate tyres or wheels on the vehicle that prevent the TPMS from functioning properly. Always check the TPMS malfunction telltale after replacing one or more tyres or wheels on your vehicle to ensure that the replacement or alternate tyres and wheels allow the TPMS to continue to function properly.

- To avoid false readings, the system samples for a little while before indicating a problem. As a result it will not instantaneously register a rapid tyre deflation or blow out.

How to Use the Tyre Pressure Monitoring System (TPMS)

Check the tyre pressure

The current tyre pressure can be checked on the centre display. Refer to the Mazda Connect Owner's Manual or consult an expert repairer (we recommend an Authorised Mazda Repairer).

Low tyre pressure warning

When a tyre pressure of the specified air pressure or lower is detected, the TPMS warning light (⚠) turns on and a warning indication is displayed in the instrument cluster.

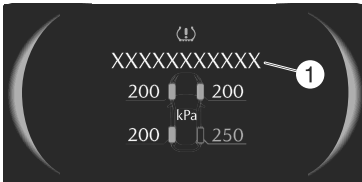

1. Message is displayed.

Action

1. Adjust the tyre pressure to the appropriate pressure. Refer to the Tyres on page 10-91.

CAUTION

If the tyre pressure is adjusted when the tyre is warm, the tyre pressure may lower below the specified pressure after cooling and the warning light may turn on. Adjust the air pressure of the tyres when they are cold.

2. Make sure that the TPMS warning light (⚠) is turned off.

3. If the TPMS warning light (⚠) does not turn off, drive the vehicle for 3 minutes or longer at a speed of 25 km/h (16 mph) or faster.
4. Make sure that the TPMS warning light (⚠) is turned off.

If the TPMS warning light remains on even after adjusting the tyre pressure, there is a possibility that the tyre is flat.

CAUTION

When inspecting/adjusting the tyre pressures, do not apply excessive force to the air valve of the tyre pressure sensor. Otherwise, the tyre pressure sensor could be damaged.

When changing tyres and wheels

When changing the tyres or wheels (such as installing winter tyres), it will be necessary to register the ID signal code of the tyre pressure sensor to the TPMS.

Have an expert repairer (we recommend an Authorised Mazda Repairer) do the registration and register the ID signal codes of the tyre pressure sensors using the following procedure.

NOTE

The tyre pressure sensors on each wheel have a unique ID signal code. For the TPMS to operate correctly, the ID signal codes of the tyre pressure sensors need to be registered to the system.

1. Wait more than 19 minutes after changing a tyre or wheel.
2. After more than 19 minutes have passed, drive the vehicle at a speed of 25 km/h (16 mph) or faster for 3 minutes or longer. While driving, the ID signal codes of the tyre pressure sensors are automatically registered.

NOTE

If you drive the vehicle within 19 minutes of changing a tyre or wheel, the TPMS warning light  will flash because the ID signal codes for the tyre pressure sensors were not registered. In this case, stop the vehicle and register the ID signal codes of the tyre pressure sensors following the procedure.

When replacing tyres and wheels

- When replacing the tyres and wheels, consult an expert repairer (we recommend an Authorised Mazda Repairer) Otherwise, the tyre pressure sensors could be damaged when replacing them.
- Do not install non-genuine wheels. If wheels other than genuine ones are installed, it may not be possible to install the tyre pressure sensors.

When replacing a tyre or wheel, always install the tyre pressure sensor. The following combinations of tyres, wheels, or tyres and wheels are possible.

- The tyre pressure sensor from the old wheel is removed and it is installed to the new wheel.
- Only a tyre is replaced without replacing the tyre pressure sensor and wheel.
- A new tyre pressure sensor is installed to a new wheel.

NOTE

When installing a new tyre pressure sensor, the ID signal code for the tyre pressure sensor needs to be registered. For details on purchasing a tyre pressure sensor and registering the ID signal of the tyre pressure sensor, consult an expert repairer (we recommend an Authorised Mazda Repairer).

Petrol Particulate Filter*

The petrol particulate filter collects and removes most of the particulate matter (PM) in the exhaust gas of a petrol engine. PM collected by the petrol particulate filter is removed naturally while the vehicle is being driven with the engine warmed up.

Diesel Particulate Filter (DPF) (e-SKYACTIV D)

The DPF collects and removes most of the particulate matter (PM) contained in the exhaust gas of diesel engines. PM collected by the DPF is removed during normal driving, however, PM may not be removed automatically under the following conditions.

- The vehicle is driven at about 5 km/h (3 mph) or slower continuously.
- The vehicle is repeatedly driven for short periods of 10 minutes or shorter or repeatedly driven in such a way that the engine cannot be warmed up.
- The vehicle is idled for a long time.

Selective Catalytic Reduction (SCR) System

Selective Catalytic Reduction (SCR) System*

The SCR system uses AdBlue® to reduce nitrogen oxide (NOx) in the exhaust gas.

Warning and Cautions for Using the Selective Catalytic Reduction (SCR) System

WARNING

Be careful not to allow the AdBlue® fluid to run out. If the AdBlue® fluid completely runs out, the SCR system will not operate normally.

When the remaining AdBlue® is low, a message is displayed on the multi-information display, and the SCR warning light turns on/flashes.

Refer to Selective Catalytic Reduction (SCR) Warning Light on page 8-56.

In this case, consult an expert repairer (we recommend an Authorised Mazda Repairer).

If AdBlue® needs to be replenished, add AdBlue® following the specified procedure.

Refer to Replenishing AdBlue® (With Selective Catalytic Reduction (SCR) System) on page 9-45.

CAUTION

Use a Mazda genuine product or a product conforming to ISO22241-1 for AdBlue®. If incompatible AdBlue® is used, the SCR system may not operate normally. In addition, the use of incompatible AdBlue® may be subject to fines and penalties. For the recommended AdBlue®, consult the expert repairer (we recommend an Authorised Mazda Repairer).

How to Use the Selective Catalytic Reduction (SCR) System

AdBlue® level is low

When the AdBlue® level is low, a message is displayed in the instrument cluster.

Add AdBlue® as needed according to the instructions.

Refer to Replenishing AdBlue® (With Selective Catalytic Reduction (SCR) System) on page 9-45.

Vehicle speed is restricted after AdBlue® is refilled

After refilling AdBlue®, the vehicle speed may be restricted even if the warning light turns off.

1. Switch the vehicle power OFF with the warning light off.
2. Switch the vehicle power ON again.

Warnings and Cautions for When the Refuelling

WARNING

Always heed the following when refuelling.

- Turn off the engine.
- Keep sparks and flames away from the fuel-filler port.
- Wipe off any spilled fuel as soon as possible.

Otherwise, it could cause a fire or explosion because fuel or fuel vapour could ignite easily.

Before refuelling, make sure to discharge the static electricity in your body by touching a metal object on the vehicle body.

An electrical discharge could ignite the fuel or cause serious burns.

Always heed the following while refuelling.

- Always refuel the vehicle by yourself and do not allow other people to come close to the fuel-filler port.
- Do not go back inside the cabin or touch a person or object charged with static electricity.
- Do not use any electronic devices such as a mobile phone or Smartphone.

It could ignite the fuel or cause serious burns caused by the charged static electricity in your body again.

When opening/closing the fuel-filler cap, always turn the fuel-filler cap by holding the knob of the fuel-filler cap. An electrical discharge could ignite the fuel or cause serious burns.

Slowly open the fuel-filler cap, wait for any hissing to stop, then open the cap.

If the fuel-filler cap is opened quickly, fuel may spray out and cause a fire. Spraying fuel can also be harmful if it gets in the eyes or on the skin.

Do not breath fuel vapours.

Toxic substances might be included in the fuel.

Insert the refuelling nozzle into the fuel-filler port securely.

If the nozzle is not inserted sufficiently, it may delay the auto stop when the tank is full, resulting in the fuel spilling over and a possible fire.

Do not continue fueling after it is stopped automatically.

If you continue fueling, fuel may spill over causing a fire.

Do not pull out the refuelling nozzle immediately after the fuel is stopped automatically.

The fuel remaining in the refuelling nozzle may spill out and cause a fire.

Securely close the fuel-filler cap.

If the fuel-filler cap is not closed securely, fuel may leak while driving the vehicle which could cause a fire.

CAUTION

- Follow the fueling instructions indicated at the gas station when refuelling.
- Always close the door and windows when refuelling. If a fire occurs with the doors or windows open, the flames may spread into cabin.
- Do not spill fuel on the vehicle while refuelling. It may cause discolouration, stains, or paint damage.
- Do not use any non-genuine fuel-filler cap. Use of a non-genuine fuel-filler cap may lead to a malfunction in the fuel system or emission system.
- When using an automatic car wash or a high water pressure car wash, make sure that the fuel flap is closed and lock the doors. Otherwise, the fuel flap may open unexpectedly and become damaged.

Refuelling

1. Close all the doors, windows, and the liftgate.
2. Switch the vehicle power OFF.
3. Unlock the driver's door.
4. Press the fuel-filler flap.
The fuel-filler flap opens.

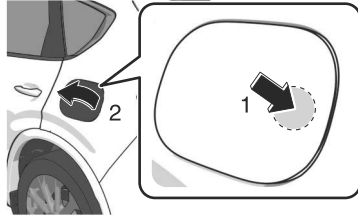

5. Slowly turn the fuel-filler cap.
The fuel-filler cap opens.

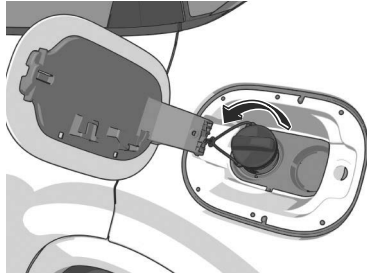

6. Place the fuel-filler cap on the fuel-filler flap holder.

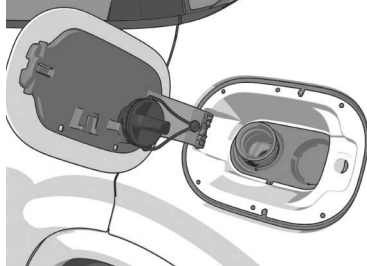

7. Insert the refuelling nozzle all the way and begin refuelling.
8. Turn the fuel-filler cap until a click sound is heard.
9. Close the fuel-filler flap.

NOTE

- If the fuel-filler flap is closed after locking the doors, the fuel-filler flap will not be locked.
- If the doors are locked by any of the following functions, the fuel-filler flap is also locked at the same time.
 - Vehicle speed sensing auto door lock function
 - Auto re-lock function

Fuel Requirements

Petrol engine

Vehicles with catalytic converters or oxygen sensors must use **ONLY UNLEADED FUEL**, which will reduce exhaust emissions and keep spark plug fouling to a minimum.

To achieve maximum engine performance, use the specified fuel.

Fuel	Research Octane Number	Country
Premium unleaded fuel (Conforming to EN 228 and within E10) ^{*1} 	95 or above	Algeria, Antigua, Armenia, Aruba, Azerbaijan, Bahrain, Barbados, Belarus, Bolivia, Botswana, Brunei, Cambodia ^{*2} , Colombia ^{*2} , Dominican Republic (LHD) ^{*2} , Egypt, Georgia, Ghana ^{*2} , Grenada, Guatemala, Haiti ^{*2} , Honduras, Hong Kong, Iraq, Israel, Jamaica, Jordan ^{*2} , Kazakhstan, Kuwait, Lebanon, Lesotho, Libya, Macau, Madagascar, Mauritius, Mongolia, Namibia, New Caledonia, Nicaragua, Oman ^{*3} , Paraguay, Peru ^{*2} , Qatar ^{*3} , Russia, Saudi Arabia ^{*3} , Seychelles, Singapore, South Africa, St. Lucia, St. Martin, St. Vincent, Surinam, Swaziland, Tahiti, Taiwan, Tunisia, UAE, Ukraine, Uruguay, Vanuatu
Regular unleaded fuel	92 or above	Myanmar
	90 or above	Angola, B. Virgin, Burundi, Cambodia ^{*3} , Cameroon, Chile, Colombia ^{*3} , Commonwealth of Dominica, Costa Rica, Curacao, Dominican Republic (LHD) ^{*3} , Ecuador, El Salvador, Fiji, Gabon, Ghana ^{*3} , Haiti ^{*3} , Indonesia, Ivory Coast, Jordan ^{*3} , Kenya, Laos, Marshall Islands, Mozambique, Nepal, Nigeria, Oman ^{*2} , Panama, Papua New Guinea, Peru ^{*3} , Qatar ^{*2} , Saudi Arabia ^{*2} , Sri Lanka, Tanzania, The Philippines, Trinidad and Tobago, Ustt ^{*4} , Zimbabwe

^{*1} Europe

^{*2} e-SKYACTIV G

^{*3} SKYACTIV-G

^{*4} Republic of Palau & Federated States of Micronesia

Fuel with a lower rating will negatively affect the emission control system performance and could also cause engine knocking and serious engine damage.

Diesel engine

The vehicle will operate efficiently on diesel fuel with specification EN590 or the equivalent.



NOTE

When refuelling, always add at least 10 L (2.6 US gal, 2.2 Imp gal) of fuel.

Warnings and Cautions for Using the Fuel Requirements

Petrol engine

CAUTION

- **USE ONLY UNLEADED FUEL.**
Leaded fuel is harmful to the catalytic converter and oxygen sensors and will lead to deterioration of the emission control system and or failures.
- The use of E10 fuel with 10 % ethanol in Europe is safe for your vehicle. Damage to your vehicle may occur when ethanol exceeds this recommendation.
- Never add fuel system additives other than a Mazda genuine product, otherwise the emission control system could be damaged. Consult an expert repairer (we recommend an Authorised Mazda Repairer) for details.

Diesel engine

CAUTION

- Never use fuel other than specification EN590 or the equivalent for your vehicle. Use of petrol or paraffin in diesel engines will result in engine damage.
- Never add fuel system additives other than a Mazda genuine product, otherwise the emission control system could be damaged. Consult an expert repairer (we recommend an Authorised Mazda Repairer) for details.

Deposit Cleaner

To get the best performance out of our newest-technology SKYACTIV petrol engines, cleaning of deposits adhering to the fuel related system, such as fuel injectors, may be required by using a Mazda genuine deposit cleaner in the specified countries.

Refer to Maintenance Table on page 9-6.

Warnings and Cautions for Using the Deposit Cleaner

CAUTION

- According to the inspection result of scheduled maintenance, Mazda genuine deposit cleaner is to be used. Neglected deposits in the fuel system may cause malfunction indicator light coming on to indicate an engine malfunction, and if the vehicle continues to be driven under this condition, it could result in problems occurring such as idling failure and poor acceleration.
- The Mazda genuine deposit cleaner is not a guarantee of engine performance no matter the quality of the fuel used. When a problem occurs even though the specified fuel is used and the Mazda genuine deposit cleaner is used according to the instructions, consult an expert repairer (we recommend an Authorised Mazda Repairer).
- If a deposit cleaner other than the Mazda genuine product is used, it could result in damage to the fuel system or the engine internally; therefore use only the Mazda genuine product. Mazda genuine deposit cleaner: K002 W0 001A
- If cleaning required according to the inspection result of scheduled maintenance is not done with the Mazda genuine deposit cleaner, repair cost for engine malfunctions caused by deposits are borne by the customer.

How to Use the Deposit Cleaner

With the fuel tank full, infuse 1 bottle of Mazda genuine deposit cleaner directly into the fuel tank.

NOTE

- Infusing the deposit cleaner when the fuel tank is full provides the concentration of cleaner within the range effective for removing the deposits and the best cleaning results can be obtained by the full tank of fuel with the infused deposit cleaner contacting the deposits for a long period of time until the full tank of fuel is nearly used up.

Emission Control System

This vehicle is equipped with an emission control system (the catalytic converter is part of this system) that enables the vehicle to comply with existing exhaust emissions requirements.

Warnings and Cautions for Using the Emission Control System

WARNING

Never park over or near anything flammable.

Parking over or near anything flammable, such as dry grass, is dangerous. Even with the engine turned off, the exhaust system remains very hot after normal use and could ignite anything flammable. A resulting fire could cause serious injury or death.

CAUTION

Ignoring the following precautions could cause lead to accumulate on the catalyst inside the converter or cause the converter to get very hot. Either condition will damage the converter and cause poor performance.

- **(Petrol engine)**
 - USE ONLY UNLEADED FUEL.
- Do not drive your Mazda with any sign of engine malfunction.
- Do not coast if the vehicle power is switched OFF.
- Do not descend steep grades in gear if the vehicle power is switched OFF.
- Do not operate the engine at high idle for more than 2 minutes.
- Do not tamper with the emission control system. All inspections and adjustments must be made by a qualified technician.
- Do not push-start or pull-start this vehicle.

Warnings and Cautions for Engine Exhaust (Carbon monoxide)

WARNING

Do not drive your vehicle if you smell exhaust gas inside the vehicle:

Engine exhaust gas is dangerous. This gas contains carbon monoxide (CO), which is colourless, odourless, and poisonous. When inhaled, it can cause loss of consciousness and death. If you smell exhaust gas inside the vehicle, keep all windows fully open and contact an expert repairer (we recommend an Authorised Mazda Repairer) immediately.

Do not run the engine when inside an enclosed area:

Running the engine inside an enclosed area, such as a garage, is dangerous. Exhaust gas, which contains poisonous carbon monoxide, could easily enter the cabin. Loss of consciousness or even death could occur.

Open the windows or adjust the heating or cooling system to draw fresh air when idling the engine:

Exhaust gas is dangerous. When the vehicle is stopped with the windows closed and the engine running for a long time even in an open area, exhaust gas, which contains poisonous carbon monoxide, could enter the cabin. Loss of consciousness or even death could occur.

Clear snow from underneath and around your vehicle, particularly the tail pipe, before starting the engine:

Running the engine when a vehicle is stopped in deep snow is dangerous. The exhaust pipe could be blocked by the snow, allowing exhaust gas to enter the cabin. Because exhaust gas contains poisonous carbon monoxide, it could cause loss of consciousness or even death to occupants in the cabin.

i-ACTIVSENSE

i-ACTIVSENSE is a collective term covering a series of advanced safety and driver support systems. i-ACTIVSENSE consists of two technologies, active safety and pre-crash safety technologies.

Warnings and Cautions for Using the i-ACTIVSENSE

WARNING

Do not rely completely on the i-ACTIVSENSE system.

The i-ACTIVSENSE system is designed to assist the driver in safe driving by reducing the load on the driver and helping to avert collisions or reduce their severity.

Because each i-ACTIVSENSE system has its limitations, always drive carefully.

Active Safety Technology

Active safety technology supports driver's safe driving and helps to prevent accidents from occurring. Active safety technology includes driver awareness support systems and driving support systems.

Driver Awareness Support Systems

Driver awareness support systems assist in the recognition of roads, signs, vehicle surroundings, and driver fatigue.

Driver awareness support systems include the following systems.

Nighttime visibility

High Beam Control System (HBC)..... page 5-146
Adaptive LED Headlights (ALH) page 5-150

Left/right side and rear detection

Lane Departure Warning System (LDWS)..... page 5-155
Blind Spot Monitoring (BSM)..... page 5-158

Road sign recognition

Traffic Sign Recognition System (TSR)..... page 5-163

Inter-vehicle distance recognition

Distance & Speed Alert (DSA) page 5-166

Forward obstruction detection when accelerating at an intersection

Front Cross Traffic Alert (FCTA) page 5-174

Rear obstruction detection when leaving a parking space

Rear Cross Traffic Alert (RCTA)..... page 5-177

Full-surround recognition

360° View Monitor..... page 5-235

Driver fatigue detection

Driver Attention Alert (DAA) page 5-168
Driver Monitoring (DM).... page 5-170

Driver Support Systems

Driver support systems assist in acceleration, deceleration, and steering operations while driving. Driver support systems include the following systems.

Inter-vehicle distance

Mazda Radar Cruise Control (MRCC)..... page 5-179

Inter-vehicle distance and lane keeping

Cruising & Traffic Support (CTS)..... page 5-192

Lane departure

Lane Keep Assist System (LAS) page 5-211

Lane keeping

Emergency Lane Keeping (ELK) page 5-220

Speed control

Adjustable Speed Limiter (ASL)..... page 5-214
Intelligent Speed Assistance (ISA)..... page 5-217

Pre-crash Safety Technology

Pre-crash safety technology is designed to assist in collision avoidance in situations where it is difficult for the driver to avert it, and to reduce damage from a collision if it occurs. Pre-crash safety technology includes the following systems.

Collision avoidance support and damage reduction

Smart Brake Support (SBS)
..... page 5-226

Collision damage reduction

Secondary Collision Reduction
..... page 5-252

i-ACTIVSENSE Status Symbol (Warning/Risk Avoidance Support System)*

Instrument cluster (Type A)

The i-ACTIVSENSE Status Symbol (Warning/Risk Avoidance Support System) indicates the status of some i-ACTIVSENSE systems.

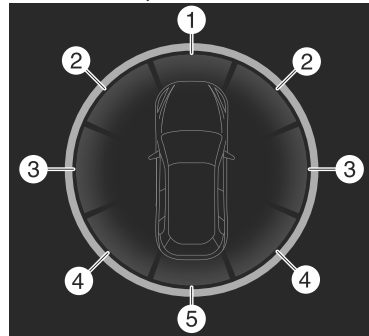

1. Front related system status
2. Front-side related system status
3. Side related system status
4. Rear-side related system status
5. Rear related system status

Target system display of the i-ACTIVSENSE status symbol (Warning/risk avoidance support system)

Front related systems

The following systems are front related systems.

- Distance & Speed Alert (DSA)
- Smart Brake Support (SBS) forward detection function
- Smart Brake Support (SBS) Turn-Across Traffic

Front-side related system

The following systems are front-side related systems.

- Front Cross Traffic Alert (FCTA)

Side related system

The following systems are side related systems.

- Lane Departure Warning System (LDWS)
- Lane-keep Assist System (LAS)
- Emergency Lane Keeping (ELK) Road Keep Assist

Rear-side related system

The following systems are rear-side related systems.

- Blind Spot Monitoring (BSM)
- Blind Spot Monitoring (BSM) Vehicle Exit Warning
- Rear Cross Traffic Alert (RCTA)
- Emergency Lane Keeping (ELK) Blind Spot Assist
- Smart Brake Support (SBS) Rear Crossing

Rear related system

The following system is a rear related system.

- Smart Brake Support (SBS) rearward detection function

How to view the i-ACTIVSENSE status symbol (Warning/risk avoidance support system)

If all target systems are on.

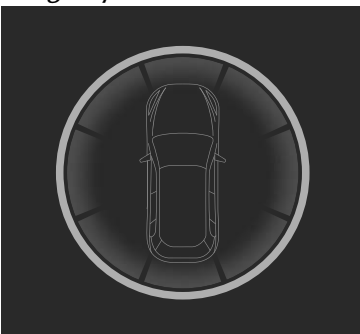

Display example if all target systems are not on.

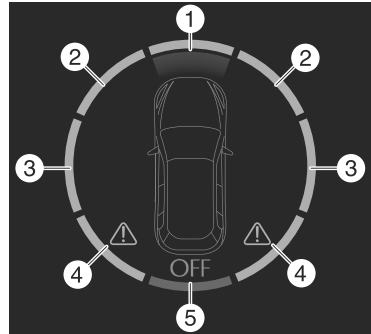

1. All front related systems are on.
2. Some front-side related systems have stopped functioning (amber).
3. Some side related systems are off (green).
4. Some rear-side related systems are malfunctioning.
5. All rear related systems are off.

Instrument cluster (Type B)

The i-ACTIVSENSE status symbol (Warning/risk avoidance support system) indicates the operating status of the following systems using the colour or OFF indication.

- Blind Spot Monitoring (BSM)
- Blind Spot Monitoring (BSM) Vehicle Exit Warning
- Distance & Speed Alert (DSA)
- Front Cross Traffic Alert (FCTA)
- Rear Cross Traffic Alert (RCTA)

i-ACTIVSENSE status symbol (Warning/risk avoidance support system) (white)  (system standby status)

If all systems do not meet the operation conditions, or if any system has stopped functioning, the i-ACTIVSENSE status symbol

(Warning/risk avoidance support system) (white)  is displayed.

i-ACTIVSENSE status symbol (Warning/risk avoidance support system) (green)  (system operation status)

If any system meets the operation conditions, the i-ACTIVSENSE status symbol (Warning/risk avoidance support system) (green)  is displayed.

NOTE

Even if the i-ACTIVSENSE status symbol (Warning/risk avoidance support system) (green) is displayed, systems which do not meet the operation conditions will not operate.

i-ACTIVSENSE status symbol (Warning/risk avoidance support system) (amber)  (system malfunction status)

If any system has a malfunction, the i-ACTIVSENSE status symbol (Warning/risk avoidance support system) (amber)  is displayed.

i-ACTIVSENSE OFF symbol (Warning/risk avoidance support system)  (system stop status)

If all the systems are cancelled using the i-ACTIVSENSE OFF switch, the i-ACTIVSENSE OFF symbol (Warning/risk avoidance support system)  is displayed.

How to Use the i-ACTIVSENSE OFF switch*

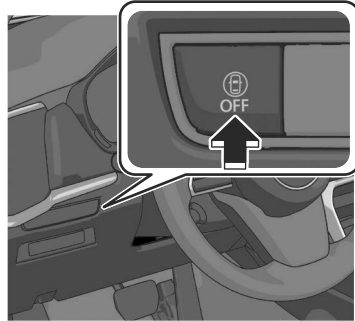

Press the i-ACTIVSENSE OFF switch to temporarily stop the following systems.

- Blind Spot Monitoring (BSM)
- Blind Spot Monitoring (BSM) Vehicle Exit Warning
- Distance & Speed Alert (DSA)
- Front Cross Traffic Alert (FCTA)
- Rear Cross Traffic Alert (RCTA)
- **(Except European models)**
 - Lane Departure Warning System (LDWS)
 - Lane-keep Assist System (LAS)
 - Emergency Lane Keeping (ELK) Road Keep Assist
 - Emergency Lane Keeping (ELK) Blind Spot Assist

Press the i-ACTIVSENSE OFF switch again to return to the previous operation status.

NOTE

If the vehicle power is switched OFF with each system turned off using the i-ACTIVSENSE OFF switch, each system automatically turns on the next time the vehicle power is switched ON.

Forward Sensing Camera (FSC)*

The Forward Sensing Camera (FSC) determines the conditions ahead of the vehicle and detects the white (yellow) lines on the traffic lane.

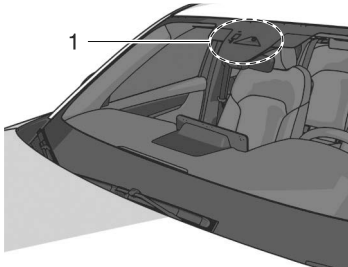

1. Forward Sensing Camera (FSC)

The following systems utilize the Forward Sensing Camera (FSC).

- High Beam Control System (HBC)
- Adaptive LED Headlights (ALH)
- Lane Departure Warning System (LDWS)
- Traffic Sign Recognition System (TSR)
- Distance & Speed Alert (DSA)
- Driver Attention Alert (DAA)
- Mazda Radar Cruise Control (MRCC)
- Cruising & Traffic Support (CTS)
- Lane-keep Assist System (LAS)
- Emergency Lane Keeping (ELK)
- Smart Brake Support (SBS) forward drive detection

! WARNING

Do not modify the suspension:

If the vehicle height or inclination is changed, the system will not be able to correctly detect vehicles ahead. This will result in the system not operating normally or mistakenly operating, which could cause a serious accident.

! CAUTION

Heed the following cautions to operate the system correctly.

- Do not hit or apply strong force to the Forward Sensing Camera (FSC) or the area around it. If the Forward Sensing Camera (FSC) received a strong impact, stop using the following systems and consult an expert repairer (we recommend an Authorised Mazda Repairer).
 - High Beam Control System (HBC)
 - Adaptive LED Headlights (ALH)
 - Lane Departure Warning System (LDWS)
 - Traffic Sign Recognition System (TSR)
 - Distance & Speed Alert (DSA)
 - Driver Attention Alert (DAA)
 - Mazda Radar Cruise Control (MRCC)
 - Cruising & Traffic Support (CTS)
 - Lane-keep Assist System (LAS)
 - Emergency Lane Keeping (ELK)
 - Smart Brake Support (SBS) forward drive detection
- Do not remove the Forward Sensing Camera (FSC) cover.
- Be careful not to scratch the Forward Sensing Camera (FSC) lens or allow it to get dirty. Also, do not take the camera apart. Otherwise, it may cause a malfunction or mis-operation.

- The direction of the Forward Sensing Camera (FSC) has been finely adjusted, therefore do not change the installation position or remove the Forward Sensing Camera (FSC). Otherwise, it may cause a malfunction or mis-operation.
- Consult an expert repairer (we recommend an Authorised Mazda Repairer) regarding cleaning of the camera lens.
- Do not place objects on the instrument panel which reflect light.
- Do not apply accessories, stickers, or film to the windscreen near the Forward Sensing Camera (FSC). If the area in front of the Forward Sensing Camera (FSC) lens is obstructed, it will cause the system to not operate correctly even if it is transparent.
- Always keep the windscreen glass around the Forward Sensing Camera (FSC) clean by removing dirt or fogging. If the windscreen is fogged, press the windscreen defroster switch.
- The Forward Sensing Camera (FSC) includes a function for detecting a soiled windscreen and informing the driver, however, depending on the conditions, it may not detect plastic shopping bags, water or snow on the windscreen. In such cases, the system cannot accurately determine a vehicle or obstruction in front and may not be able to operate normally. Always drive carefully and pay attention to the road ahead.
- When cleaning the windscreen, do not allow glass cleaners or similar cleaning fluids to get on the Forward Sensing Camera (FSC) lens. In addition, do not touch the Forward Sensing Camera (FSC) lens.
- Consult an expert repairer (we recommend an Authorised Mazda Repairer) regarding cleaning the interior side of the windscreen around the Forward Sensing Camera (FSC).
- If there are cracks or damage caused by flying gravel or debris on the windscreen, always have the windscreen replaced. Consult an expert repairer (we recommend an Authorised Mazda Repairer) before replacing the windscreen.
- Consult an expert repairer (we recommend an Authorised Mazda Repairer) before doing repairs around the Forward Sensing Camera (FSC).
- When doing repairs around the rearview mirror, consult an expert repairer (we recommend an Authorised Mazda Repairer).
- Always use tyres of the specified size and the same manufacturer, brand, and tread pattern on all 4 wheels. In addition, do not use tyres with significantly different wear patterns or tyre pressures on the same vehicle (including temporary spare tyre).

NOTE

- If the Forward Sensing Camera (FSC) does not function normally due to fog or the vehicle being driven towards the sun, the functions related to the Forward Sensing Camera (FSC) are temporarily stopped. In this case, the following warning indications turn on. However, this does not indicate a problem.
 - HBC warning indication
 - ALH warning indication
 - i-ACTIVSENSE warning indication
 - SBS OFF indication

· If the Forward Sensing Camera (FSC) does not function normally due to high temperatures, the functions related to the Forward Sensing Camera (FSC) are temporarily stopped. In this case, the following warning indications turn on. However, this does not indicate a problem. Cool down the area around the Forward Sensing Camera (FSC) such as by turning on the air conditioner.

- HBC warning indication
- ALH warning indication
- i-ACTIVSENSE warning indication
- SBS OFF indication

· When the Forward Sensing Camera (FSC) detects that the windscreen is dirty or foggy, the functions related to the Forward Sensing Camera (FSC) are temporarily stopped. In this case, the following warning indications turn on. However, this does not indicate a problem. Remove the dirt from the windscreen or press the windscreen defroster switch.

- HBC warning indication
- ALH warning indication
- i-ACTIVSENSE warning indication
- SBS OFF indication

Detection of pedestrians

The Forward Sensing Camera (FSC) detects pedestrians when all of the following conditions are met.

- The height of a pedestrian is about 1 to 2 meters.
- The outline of a pedestrian is recognised such as the head, both shoulders, or the feet.

The Forward Sensing Camera (FSC) may not be able to detect pedestrians when any of the following conditions is met.

- There are multiple pedestrians.
- A pedestrian is close to a separate object.
- A pedestrian is crouching, lying, or slouching.
- A pedestrian suddenly jumps into the road.
- A pedestrian is holding something (such as an open umbrella or large baggage).
- A pedestrian blends into the background (such as in a dark location at night or by wearing clothes matching the background colour).

Detection of objects

When any of the following conditions is met, the Forward Sensing Camera (FSC) may not be able to detect target objects correctly, and each system may not operate normally.

- You are driving your vehicle at the same speed as the vehicle ahead.
- The headlights of your vehicle are not turned on during the night or in a tunnel.
- The target object is in the blind spot of the Forward Sensing Camera (FSC).
- A person or object bursts onto the road from the shoulder or cuts right in front of you.
- The distance between your vehicle and the target object is extremely close or extremely far.
- You change the course and approach a target object.
- The target object (vehicle ahead, white line (yellow line), sign) is dirty or worn.
- A vehicle ahead has a special shape (such as a vehicle carrier).
- A vehicle ahead is a truck with a low loading platform.

Forward Sensing Camera (FSC)

- A vehicle ahead has an extremely low or high profile.
- A vehicle ahead is outside the illumination range of the headlights.
- The illumination area of the tail lights of the vehicle ahead is small.
- The tail lights of a vehicle ahead are dim or turned off.
- The headlights of an on-coming vehicle are dim or turned off.
- Under bad weather conditions (rain, fog, and snow).
- Front visibility is reduced (due to a vehicle ahead casting off water, snow, or sand).
- Strong light is directed at the front of your vehicle (such as backlight and high-beam headlights).
- The surrounding area is dark (such as during the night, early evening, or early morning, or in a tunnel or indoor parking lot).
- There are light sources in the surrounding area (such as street lamps, illuminated signboards, and traffic signals).
- There are objects which reflect light (such as reflective plates and signs) in the surrounding area.
- The surrounding brightness suddenly changes (such as when entering or exiting a tunnel).
- The brightness of the headlights of your vehicle is insufficient (such as the illumination is weakened due to a dirty lens or the optical axis is deviated).
- Tyres other than the specified size are used on your vehicle (such as when tyre chains or temporary spare tyres are used).
- The tyres on your vehicle have significantly different wear.
- Foreign matter is stuck to the windscreen (such as ice, fog, snow, frost, raindrops, dirt, or a piece of plastic).
- The windscreen is dirty or fogged.
- The Forward Sensing Camera (FSC) is blocked by an obstruction, causing poor forward visibility (such as when roof rails are installed to the vehicle and a long object is loaded).
- The windscreen washer is being used.
- The windscreen wipers are not used when it is raining.
- Your vehicle is tilted (such as when heavy luggage is in the luggage compartment or on the rear seat).
- The vehicle is making a sharp curve, or ascending or descending a steep slope.
- The vehicle is driven on a road with sharp curves or up and down (wavy) slopes.
- The vehicle is driven on uneven roads.
- The vehicle is driven next to walls with no patterning (including fences and longitudinally striped walls).
- There is a strong reflection of light from the road surface.

Radar Sensors*

The radar sensor detects objects by sending radio waves in a specific direction and receiving the reflected waves back.

Vehicle front

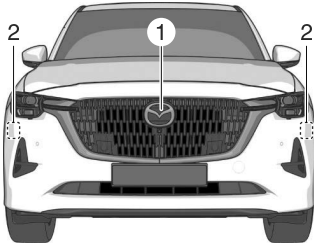

1. Front radar sensor
2. Front side radar sensors

Vehicle rear



1. Rear side radar sensors

CAUTION

- Heed the following cautions so that the radar sensors can function normally.
 - Do not modify the suspensions.
 - Always use tyres of the specified size and the same manufacturer, brand, and tread pattern on all 4 wheels. In addition, do not use tyres with significantly different wear patterns or tyre pressures on the same vehicle (including temporary spare tyre).

- Do not spray highly pressurised water against the radar sensors or rub them strongly.
- Do not apply stickers on parts near the radar sensors.
- If foreign matter adheres to parts near the radar sensors, remove it and switch the vehicle power OFF. The foreign matter detection status is reset by switching the vehicle power OFF.
- Consult an expert repairer (we recommend an Authorised Mazda Repairer) if you need to repair, replace, or paint parts near the radar sensors.
- Do not install any parts that cover the front of the radar sensors.
- Do not replace the radiator grille and emblem with anything other than genuine products.
- If strong force is applied to parts near the radar sensors, the direction of the radar sensor may become deviated and each system may not operate normally. Stop each system immediately and have the vehicle inspected by an expert repairer (we recommend an Authorised Mazda Repairer).

NOTE

- The radar sensors include a function for detecting abnormalities in the sensor, soiling of the sensor's front surface, and informing the driver. If a message appears on the screen that can be addressed, follow the directions of the message.

Front radar sensor

The following systems utilize the front radar sensor.

- Distance & Speed Alert (DSA)

- Mazda Radar Cruise Control (MRCC)
- Cruising & Traffic Support (CTS)
- Smart Brake Support (SBS) forward drive detection

NOTE

- When driving on roads with few vehicles ahead, a message may temporarily be displayed on the screen indicating that the front radar sensor is dirty.
- When the vehicle is driven on roads in which there is an elevated road on one side, the front radar sensor function may be restricted temporarily.
- If the lead-acid battery power is weak, the front radar sensor detection function may decrease and each system may not operate normally.
- When any of the following conditions is met, the front radar sensor may not be able to detect vehicles ahead or obstructions correctly.
 - During inclement weather.
 - Front visibility is reduced.
 - The vehicle is driven near facilities or objects emitting strong radio waves.
 - The rear surface of a vehicle ahead does not reflect radio waves effectively.
 - A vehicle ahead has limited areas that can reflect radio waves.
 - Your vehicle is tilted.
 - Foreign matter is adhering to parts near the front radar sensor.

- When any of the following conditions is met, the front radar sensor may detect vehicles in the adjacent lane or surrounding obstructions, or it may not be able to detect vehicles ahead or obstructions.

- The vehicle is entering or exiting a curve.
- The vehicle is driven on a continuously curving road.
- The vehicle is driven on roads with repeated up and downslopes.
- The vehicle is driven on roads with narrow lanes.
- The vehicle is driven on poor roads or unpaved roads.
- The vehicle ahead enters the front radar sensor's blind spot.
- The distance to the vehicle ahead is extremely close.
- The vehicle ahead is being driven in an unstable condition.
- A vehicle suddenly comes close such as by cutting into your lane.

Front side radar sensors

The following system utilizes front side radar sensors.

- Front Cross Traffic Alert (FCTA)

NOTE

- When any of the following conditions is met, the front side radar sensors may not be able to detect target objects.
 - During inclement weather.
 - The vehicle is driven on a sharp curve or on bumpy roads.
 - Radar sensor from an adjacent vehicle causes radio wave interference.

- The detection range of a front side radar sensor is obstructed by an adjacent wall or vehicle, or the radar is reflected.
- A vehicle suddenly enters the detection range from the front or side of your vehicle.
- The target object is extremely small.
- The target object is extremely low/high.
- A vehicle approaches while turning.
- A vehicle that has stopped suddenly starts to move.
- Multiple objects move at the same time.
- The bumper around a front side radar sensor is deformed.
- Foreign matter is adhering to the bumper around a front side radar sensor.
- The temperature near a front side radar sensor is extremely hot.
- The front side radar sensors may not detect the following target objects.
 - Animals.
 - Pedestrians.
 - Bicycles and small motorcycles moving at a low speed.
 - Shopping carts.
 - Stationary objects on the road or roadside.
 - Vehicles with shapes that may not reflect radar waves.

Rear side radar sensors

The following systems utilize rear side radar sensors.

- Blind Spot Monitoring (BSM)
- Blind Spot Monitoring (BSM) Vehicle Exit Warning
- Rear Cross Traffic Alert (RCTA)
- Smart Brake Support (SBS) Rear Crossing

- Emergency Lane Keeping (ELK) Blind Spot Assist

NOTE

- When any of the following conditions is met, the rear side radar sensors may not be able to detect target objects.
 - During inclement weather.
 - The vehicle is driven on a sharp curve or on bumpy roads.
 - Radar sensor from an adjacent vehicle causes radio wave interference.
 - The detection range of a front side radar sensor is obstructed by an adjacent wall or vehicle, or the radar is reflected.
 - A vehicle suddenly enters the detection range from the front or side of your vehicle.
 - The target object is extremely small.
 - The target object is extremely low/high.
 - A vehicle approaches while turning.
 - A vehicle that has stopped suddenly starts to move.
 - Multiple objects move at the same time.
 - The bumper around a rear side radar sensor is deformed.
 - Foreign matter is adhering to the bumper around a rear side radar sensor.
 - The temperature near a rear side radar sensor is extremely hot.
 - When towing a trailer.
- The rear side radar sensors may not detect the following target objects.
 - Animals.
 - Pedestrians.
 - Bicycles and small motorcycles moving at a low speed.

- Shopping carts.
- Stationary objects on the road or roadside.
- Vehicles with shapes that may not reflect radar waves.
- A vehicle is travelling alongside your vehicle at nearly the same speed for an extended period of time.

Ultrasonic Sensors*

The ultrasonic sensors detect objects by sending ultrasonic waves in a specific direction and receiving the reflected waves back.

Front ultrasonic sensors

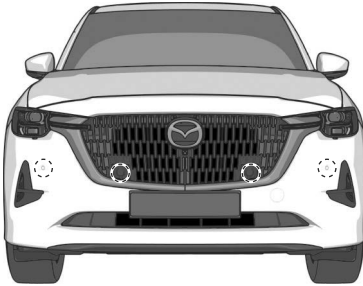

Rear ultrasonic sensors



Detection ranges of ultrasonic sensors

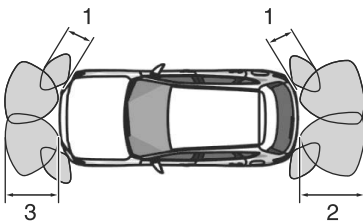

1. About 50 cm (20 in)
2. About 1 m 50 cm (59 in)
3. About 1 m (39.3 in)

⚠ CAUTION

- Heed the following cautions so that the ultrasonic sensors can function normally.
 - Do not modify the suspensions.
 - Do not spray highly pressurised water against the ultrasonic sensors or rub them strongly.
 - Do not apply stickers on the ultrasonic sensors.
 - Consult an expert repairer (we recommend an Authorised Mazda Repairer) if you need to repair, replace, or paint the bumper.
- Depending on the type of target object and surrounding conditions, the distance at which the ultrasonic sensors can detect target objects may be shortened or the target objects may not be detected. Always confirm the safety around the vehicle visually when driving.
- If strong force is applied to parts near the ultrasonic sensors, the direction of the ultrasonic sensor may become deviated and each system may not operate normally. Stop each system immediately and have the vehicle inspected by an expert repairer (we recommend an Authorised Mazda Repairer).

NOTE

- The ultrasonic sensors include a function for detecting abnormalities in the sensor, soiling of the sensor's front surface, and informing the driver. If a message appears on the screen that can be addressed, follow the directions of the message.

- When any of the following conditions is met, the ultrasonic sensors may not be able to detect target objects, and each system may not operate normally.
 - Target object is thin such as wire, rope, or poles.
 - Target object absorbs waves easily such as cotton or snow.
 - Target object has an angular shape.
 - Target object is tall and wide at the upper part.
 - Target object height is low.
 - There are multiple target objects.
 - Target objects are too close to the sensors.
 - Ice, snow, or mud is adhering to the sensor area.
 - Heavy rainfall or pressurised water is applied to the sensor area.
 - The sensor areas are frozen.
 - You cover the sensor with your hand.
 - The area around the sensor has received a strong impact.
 - The vehicle is excessively tilted.
 - Under extremely hot or cold weather.
 - Approached by an object that generates ultrasonic waves, such as the horn of another vehicle, the engine noise of a motorcycle, the air brake noise of a large vehicle, or the sensor of another vehicle.
 - A commercially-available wing pole or an aerial for a radio transmitter is installed to the vehicle.
 - The vehicle is moving towards a tall or square curbstone, or a steep grade.
 - The vehicle is moving towards an uneven wall or stairs.
 - The vehicle is driven in a place with low ceilings.

- The vehicle is driven on bumpy roads, inclines, gravel roads, dense grass, or grating.
- The ultrasonic sensor does not detect target objects directly beneath the bumper. Even if target objects which are located at a position lower than an ultrasonic sensor have been detected, the ultrasonic sensor may suddenly stop detecting as the vehicle approaches the target object.

Front ultrasonic sensors

The following systems utilize front ultrasonic sensors.

- Parking Sensor

Rear ultrasonic sensors

The following systems utilize rear ultrasonic sensors.

- Smart Brake Support (SBS) reverse drive detection
- Parking Sensor

Cameras*

The cameras shoot images of the area surrounding the vehicle.

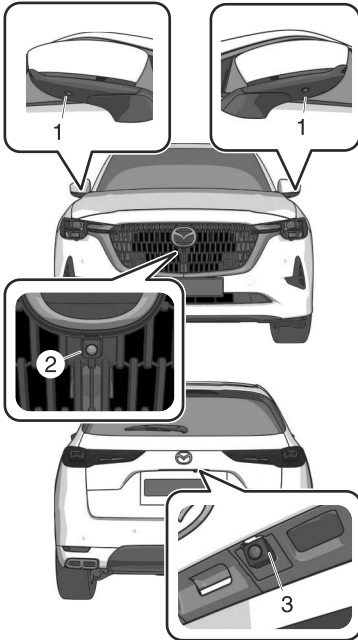

1. Side cameras
2. Front camera
3. Rear camera

CAUTION

- Do not disassemble, modify, or remove a camera.
- Consult an expert repairer (we recommend an Authorised Mazda Repairer) if you need to repair, replace, or paint parts near the cameras.
- If strong force is applied to a camera, the camera position and the installation angle may shift. Have your vehicle inspected by an expert repairer (we recommend an Authorised Mazda Repairer).

- Heed the following cautions so that the cameras can function normally.
 - Do not modify the suspensions.
 - Always use wheels of the specified size for the front and rear wheels. Consult an expert repairer (we recommend an Authorised Mazda Repairer) for tyre replacement.
- Do not apply oil film remover, organic solvents, wax or coating agents, because the camera cover is made of hard plastic. If any such agent is applied, wipe it off using a soft cloth immediately.
- Do not rub a camera cover forcefully with an abrasive or hard brush. The camera cover or lens might be scratched which might affect the images.
- If the lens of the camera is badly damaged by flying gravel, replace the camera. For the camera replacement, consult an expert repairer (we recommend an Authorised Mazda Repairer).
- Depending on the type of target object and surrounding conditions, the distance at which the camera can detect target objects may be shortened or the target objects may not be detected. Always confirm the safety around the vehicle visually when driving.

NOTE

- Do not apply stickers and do not install accessories or illuminated number/character number plates to the area around a camera. Otherwise, the camera may not correctly display the surrounding conditions.

- If a camera is affected by excessive changes in temperature such as pouring hot water on the camera during cold weather, the camera may not operate normally.
- The cameras include a function for detecting abnormalities in the camera, soiling of the camera's front surface, and informing the driver. If a message appears on the screen that can be addressed, follow the directions of the message.
- If there are water droplets, snow, or mud on the camera lens, wipe it off using a soft cloth. If the camera lens is especially dirty, wash it off with mild detergent.

Front camera

The following system use the front camera.

- 360° View Monitor

Side cameras

The following system use the side cameras.

- 360° View Monitor

Rear camera

The following systems use rear camera.

- Smart Brake Support (SBS) reverse drive detection
- 360° View Monitor
- Rear View Monitor

Detection of pedestrians

The rear camera detects pedestrians when all of the following conditions are met.

- The height of a pedestrian is about 1 to 2 meters.
- The outline of a pedestrian is recognised such as the head, both shoulders, or the feet.

If any of the following conditions is met, the rear camera may not be able to accurately detect pedestrians and the Smart Brake Support (SBS) reverse drive detection may not operate correctly.

- There are multiple pedestrians.
- A pedestrian is close to a separate object.
- A pedestrian is crouching, lying, or slouching.
- A pedestrian suddenly jumps into the road.
- A pedestrian is holding something (such as an open umbrella or large baggage).
- A pedestrian blends into the background (such as in a dark location at night or by wearing clothes matching the background colour).
- The surrounding area is dark (such as during the night, early evening, or early morning, or in a tunnel or indoor parking lot).
- Foreign matter is adhering to the rear camera (water droplets, snow, mud).
- The rear camera is exposed to strong light (sunlight, vehicle headlights).

Driver Monitoring Camera*

The driver monitoring camera detects changes in the driver's facial features and estimates the driver's condition.

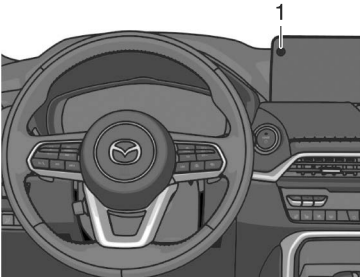

1. Driver monitoring camera

The following systems use the driver monitoring camera.

- Driver Monitoring (DM)
- Smart Brake Support (SBS) forward detection function
- Driver Personalisation System

NOTE

- Each system may not operate normally if any of the following conditions is met.
 - You are wearing glasses or sunglasses
 - A cap or hat you are wearing partially blocks the driver monitoring camera's view of your eyes, you have long bangs partially covering your eyes, or a part of your face is invisible due to a scarf, face mask, beard, or hand.
 - The lighting conditions change significantly (such as backlight, light from the side, direct light from the setting sun, or the headlights of on-coming vehicles)

- Device that emits near-infrared light is used in the cabin.
- The temperature in the cabin is high.
- The driver monitoring camera is blocked by hands or arms.
- There is more than one face in the detection range of the driver monitoring camera, such as when the front passenger or a rear seat passenger leans forward.
- The driver's face is far out of the detection range of the driver monitoring camera, such as when the driver's face is put outside of the window.

High Beam Control System (HBC)*

The HBC determines the conditions in front of the vehicle while driving at night to automatically switch the headlights between high and low beams.

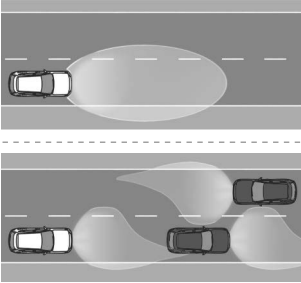

Warnings and Cautions for Using the High Beam Control System (HBC)

CAUTION

- Heed the following cautions so that the HBC can operate normally.
 - Do not modify the suspensions.
 - Do not modify the headlight units.
 - Do not remove the Forward Sensing Camera (FSC).
- Do not rely completely on the system and switch the headlights between the high and low beams manually if necessary.

How to Use the High Beam Control System (HBC)

NOTE

- The distance in which the HBC can detect objects varies depending on the surrounding conditions.
- The Forward Sensing Camera (FSC) may not be able to detect target objects correctly, and the HBC may not operate normally. Refer to Forward Sensing Camera (FSC) on page 5-133.

Using the HBC

Make sure that the light switch is in the AUTO position.

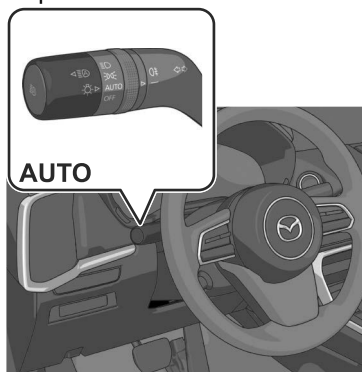

The HBC determines the surrounding conditions and operates automatically. When the HBC operates, the HBC indicator light (green)  in the instrument cluster turns on.

Switching the headlights to high beams

The HBC switches the headlights to high beams when all of the following conditions are met.

- The vehicle speed is about 30 km/h (19 mph) or faster.
- The system does not detect a vehicle ahead.

Switching the headlights to low beams

The HBC switches the headlights to low beams when any of the following conditions is met.

- The vehicle speed is less than about 20 km/h (12 mph).
- When driving in areas with a continuous line of street lamps or on roads in well-lit cities and towns.
- The system detects the headlights of a vehicle ahead.

Cancelling the HBC during operation

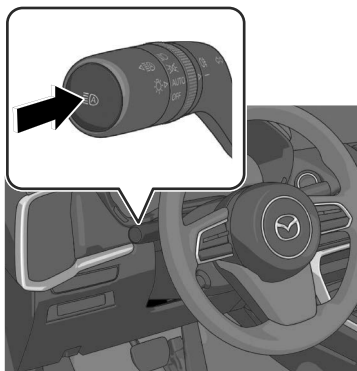

When the HBC is cancelled, the HBC indicator light (green)  in the instrument cluster turns off. Press the HBC switch again to make the HBC operable.

NOTE

If the vehicle power is switched OFF with the HBC turned off, the HBC automatically turns on the next time the vehicle power is switched ON.

Turning off the HBC

The HBC can be turned off using Mazda Connect.
Refer to the Settings section in the Mazda Connect Owner's Manual.

Adaptive LED Headlights (ALH)

Adaptive LED Headlights (ALH)*

The ALH are a system which determines the conditions ahead while driving at night to automatically switch the illumination range of the headlights or the illumination brightness. The ALH has the following 4 functions.

Glare-free high beams

When the high-beam are on, the illumination on vehicles ahead and bright signs is dimmed.

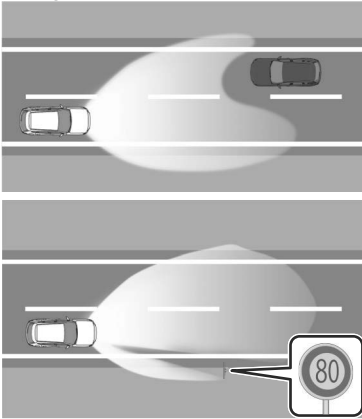

Marking light

Headlights brightly illuminate pedestrians that may collide with the vehicle.

Headlights are switched to low beams

Illuminates pedestrians with a partial, high-beam light source.

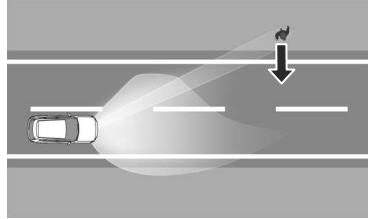

Headlights are switched to high beams

Only the illumination on pedestrians flashes.

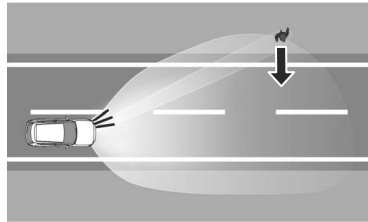

Wide-range low beam

Extends the illumination range of the low beams.



Highway mode

This feature shifts the illumination angle of the headlights upward while driving at high speeds.

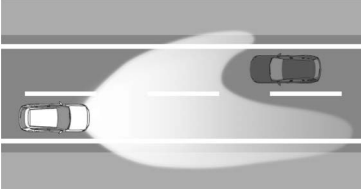

Warnings and Cautions for Using the Adaptive LED Headlights (ALH)

CAUTION

- Heed the following cautions so that the ALH can operate normally.
 - Do not modify the suspensions.
 - Do not modify the headlight units.
 - Do not remove the Forward Sensing Camera (FSC).
- Do not rely completely on the system. Switch the headlights between the high and low beams manually if necessary.

How to Use the Adaptive LED Headlights (ALH)

NOTE

- The Forward Sensing Camera (FSC) may not be able to detect target objects correctly, and the ALH may not operate normally. Refer to Forward Sensing Camera (FSC) on page 5-133.
- Depending on the position and brightness of signs, the glare-free high beams may not operate normally.
- The marking light may not work normally depending on the position and movement of pedestrians.

Using the ALH

Make sure that the light switch is in the AUTO position.

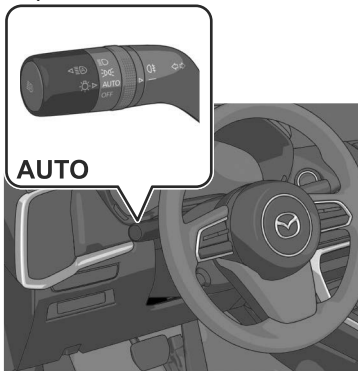

The ALH operates automatically after determining the surrounding conditions.

When the ALH operates, the ALH indicator light (green)  in the instrument cluster turns on.

When the glare-free high beams operate

The glare-free high beams operate when all of the conditions according to the target are met.

- **(If an object is a vehicle ahead)**
 - The vehicle speed is about 30 km/h (19 mph) or faster.
 - The system detects a vehicle ahead.
- **(If an object is a sign)**
 - The vehicle speed is about 60 km/h (37 mph) or faster.
 - The system detects a bright sign.

Marking light operation conditions

The marking light operates when all of the following conditions are met.

- The vehicle speed is about 20 km/h (12 mph) to 80 km/h (50 mph).
- The system detects that your vehicle may collide with a pedestrian.

The wide-range low beam operation conditions

The wide-range low beams operate when any of the following conditions is met.

- The vehicle is driven at less than about 40 km/h (25 mph).
- The direction indicator lights flash while the vehicle is stopped.

Highway mode operation conditions

Highway mode operates when the vehicle speed is about 105 km/h (65.2 mph) or faster.

Adaptive LED Headlights (ALH)

Stopping the ALH during operation

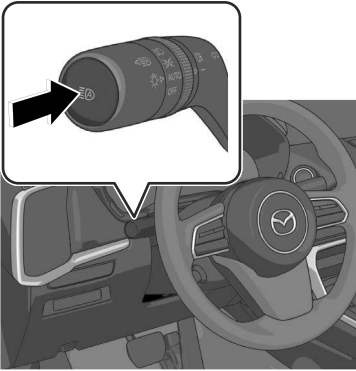

When the ALH is cancelled, the ALH indicator light (green)  in the instrument cluster turns off. Press the ALH switch again to make the ALH operable.

NOTE

- If the vehicle power is switched OFF with the ALH stopped, the ALH automatically turns on the next time the vehicle power is switched ON.

Turning off the ALH

The ALH can be turned off using Mazda Connect. Refer to the Settings section in the Mazda Connect Owner's Manual.

Lane Departure Warning System (LDWS)*

The LDWS notifies the driver that the vehicle might be deviating from its lane. If there is a possibility of your vehicle deviating from the vehicle lane, a screen display and a warning sound notify the driver of the danger.

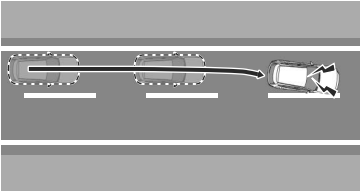

Warnings and Cautions for Using the Lane Departure Warning System (LDWS)

WARNING

Do not rely completely on the LDWS.

- The LDWS has limitations. Do not rely completely on the system and always stay on course using the steering wheel.
- The LDWS is not designed to compensate for a driver's lack of caution and relying on the system could lead to an accident.

CAUTION

Hed the following cautions so that the LDWS can operate normally.

- Do not modify the suspensions.
- Always use wheels of the specified size for the front and rear wheels. Consult an expert repairer (we recommend an Authorised Mazda Repairer) for tyre replacement.

How to Use the Lane Departure Warning System (LDWS)

LDWS operates

The LDWS operates when all of the following conditions are met.

- The vehicle speed is about 60 km/h (37 mph) or faster.
- The system detects white (yellow) lane lines.
- The CTS steering assist function is not operating.
- The system determines that the vehicle may depart from the lane.

When the LDWS is operating, a screen display and a warning sound (steering wheel vibration and warning sound) notify the driver of the danger.

Instrument cluster (Type A)

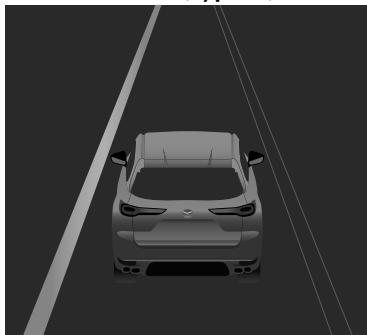

Instrument cluster (Type B)



Active driving display



NOTE

- The LDWS operates only on the side that detects white lines (yellow lines).
- The forward sensing camera (FSC) may not be able to detect target objects correctly, and the LDWS may not operate normally. Refer to Forward Sensing Camera (FSC) on page 5-133.
- The LDWS warning type can be changed using Mazda Connect. Refer to the Settings section in the Mazda Connect Owner's Manual.

LDWS is temporarily cancelled

If any of the following conditions is met, the LDWS is cancelled. In addition, the LDWS is automatically enabled when the condition changes and the system is operable.

- The direction indicator lever is operated.
- The accelerator pedal is operated.
- The steering wheel is operated.
- The brake pedal is depressed.

Turning off the LDWS

(European models)

The LDWS can be turned off using the Mazda Connect.

Refer to the Settings section in the Mazda Connect Owner's Manual.

(Except European models)

There are 2 ways to turn off the LDWS.

- Turn off the LDWS using Mazda Connect.
Refer to the Settings section in the Mazda Connect Owner's Manual.
- Turn off the LDWS using the i-ACTIVSENSE OFF switch.
Refer to How to Use the i-ACTIVSENSE OFF switch on page 5-132.

Blind Spot Monitoring (BSM)

Blind Spot Monitoring (BSM)*

The BSM is a system that assists the driver in checking for vehicles at your rear when making a lane change. When a vehicle approaching from the rear is detected, various screen displays and warning sounds notify the driver of the danger.

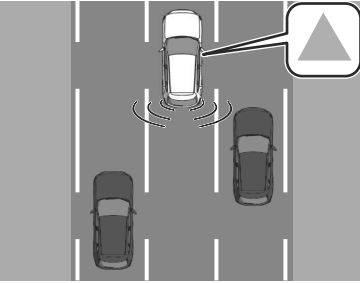

With Vehicle Exit Warning*

The vehicle exit warning is a system that assists the driver in checking the rear of the vehicle when exiting the vehicle. When a vehicle or bicycle approaching from the rear is detected, various screen displays and warning sounds notify the driver of the danger.

Warnings and Cautions for Using the Blind Spot Monitoring (BSM)

! WARNING

Always check the surrounding area visually before making a lane change. The BSM is a system to assist the driver in checking the area to the rear of the vehicle when making a lane change. Due to certain limitations with the operation of system, the BSM warning lights may not flash or it might be delayed even though a vehicle is in an adjacent lane. Always make it your responsibility as a driver to check the rear.

Always check the surrounding area visually when getting out of the vehicle.

The vehicle exit warning is a system that assists the driver in checking the area to the rear of the vehicle when exiting the vehicle. Due to certain limitations with the operation of system, the BSM warning lights may not flash or it might be delayed even though a vehicle is in the area around your vehicle. Always make it your responsibility as a driver to check the rear.

How to Use the Blind Spot Monitoring (BSM)

When the BSM operates

The BSM operates when all of the following conditions are met.

- The vehicle speed is about 30 km/h (19 mph) or faster.
- The system detects an approaching vehicle.

When the BSM operates, the driver is notified of the presence of an approaching vehicle using the BSM warning lights and a screen display (white)*1.

BSM warning light

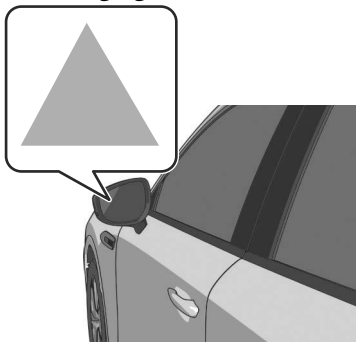

Instrument cluster (Type A)

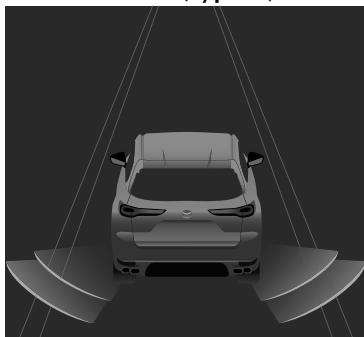

Instrument cluster (Type B)

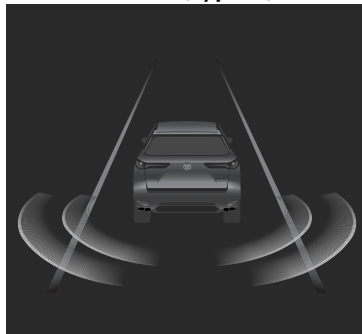

Active driving display



*1 The instrument cluster screen display (white) is displayed only when the instrument cluster is set to the i-ACTIVSENSE display.

When the direction indicator lever is operated in the direction in which an approaching vehicle is detected, the driver is notified of the danger by flashing of the BSM warning lights, the warning sound, and the warning indication (amber).

BSM warning light

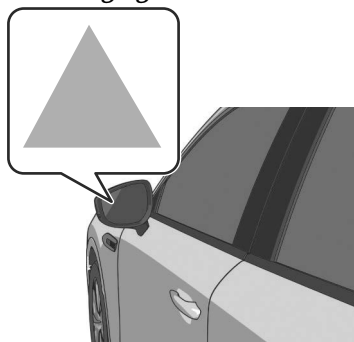

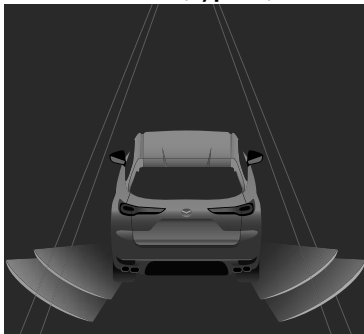
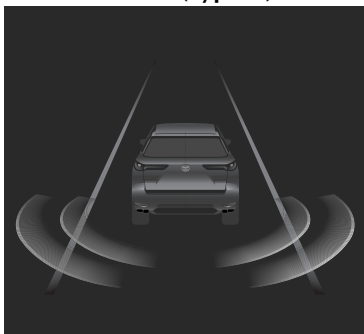
Instrument cluster (Type A)**Instrument cluster (Type B)****Active driving display****NOTE**

- The BSM may not operate normally if any of the following conditions is met.
 - The rear side radar sensors cannot detect an object. Refer to Radar Sensors on page 5-137.
 - The road is on a steep slope.
 - The road is extremely wide.
 - You make a lane change 2 lanes or more.

- The BSM may operate when turning at intersections in urban areas or with stationary objects on the road or the roadside (such as guardrails, sidewalls, and parked vehicles).
- If a Mazda genuine trailer hitch is used, the BSM is automatically turned off when the trailer's electrical connector is connected.
- When pulling a trailer other than with a Mazda genuine trailer hitch, or while an accessory such as a bicycle carrier is installed to the rear of the vehicle, turn off the BSM. Otherwise, the radar's radio waves will be blocked causing the BSM to not operate normally.
- The brightness of the BSM warning lights is linked to the panel light control. Refer to Instrument Panel Illumination on page 5-32.

When the Vehicle Exit Warning operates*

The Vehicle Exit Warning operates when all of the following conditions are met.

- The vehicle is stopped.
- Within 3 minutes after the vehicle power is switched OFF or the vehicle power is switched ON.
- The system detects an approaching vehicle.

When the Vehicle Exit Warning operates, the driver is notified of the presence of an approaching vehicle using the warning lights and the instrument cluster screen display (white)^{*1}.

BSM warning light

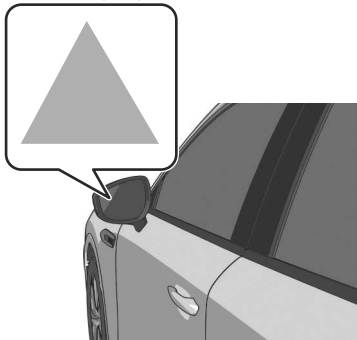

Instrument cluster (Type A)



Instrument cluster (Type B)



*1 The instrument cluster screen display (white) is displayed only when the instrument cluster is set to the i-ACTIVSENSE display. However, when the vehicle power is OFF,

the instrument cluster screen display (white) is not displayed.

In addition, when the door in the direction in which an approaching vehicle is detected is opened, the driver is notified of the danger by flashing of the warning lights, the warning sound, and the instrument cluster warning indication (amber).

BSM warning light

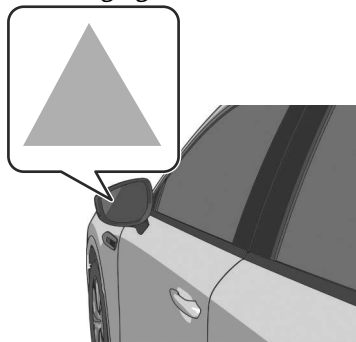

Instrument cluster (Type A)



Instrument cluster (Type B)

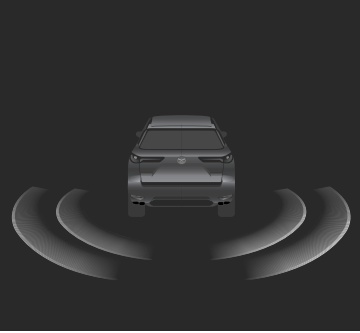

NOTE

- The Vehicle Exit Warning may not operate normally if any of the following conditions is met.
 - The rear side radar sensors cannot detect an object.
Refer to Radar Sensors on page 5-137.
 - There is a parked vehicle near your vehicle.
 - Moving objects are slow.
- The Vehicle Exit Warning is not automatically turned off even if a Mazda genuine trailer hitch is used.
- If a trailer is towed or a bicycle carrier is attached to the rear of the vehicle, the radar signal may be blocked and the Vehicle Exit Warning may not operate correctly.
- The Vehicle Exit Warning may operate with stationary objects on the road or the roadside (such as guardrails, sidewalls, and parked vehicles).
- The brightness of the BSM warning lights is linked to the panel light control.
Refer to Instrument Panel Illumination on page 5-32.

Turning off the BSM and the Vehicle Exit Warning

There are 2 ways to turn off the BSM and the Vehicle Exit Warning.

- Turn off the BSM and the Vehicle Exit Warning using Mazda Connect.
Refer to the Settings section in the Mazda Connect Owner's Manual.
- Turn off the BSM and the Vehicle Exit Warning using the i-ACTIVSENSE OFF switch.
Refer to How to Use the i-ACTIVSENSE OFF switch on page 5-132.

Traffic Sign Recognition System (TSR)*

The TSR is a system to notify the driver of traffic signs by displaying traffic signs on the screen which are recognised by the vehicle while driving.

Warnings and Cautions for Using the Traffic Sign Recognition System (TSR)

WARNING

Always check the traffic signs visually while driving.

Depending on weather and traffic sign conditions, the TSR may not recognise traffic signs or it may display them differently. Always make it your responsibility as a driver to check the actual traffic signs. Otherwise, it could result in an accident.

How to Use the Traffic Sign Recognition System (TSR)

NOTE

- The TSR operates even if the SD card of the navigation system is not inserted, but a traffic sign different from the actual traffic sign may be displayed.
- The TSR may not operate normally if any of the following conditions is met.
 - The Forward Sensing Camera (FSC) does not detect traffic signs correctly. Refer to Forward Sensing Camera (FSC) on page 5-133.
 - **(Vehicles with navigation system)**
 - The map has not been updated to the latest version.
 - The speed limit sign included in the map is inaccurate.
 - The map does not contain a speed limit sign.
 - The vehicle position in the navigation system is deviated.
- The TSR may display signs at the same time in any of the following patterns.
 - Displays only a single traffic sign at the same time.
 - Displays a speed limit sign and conditional speed sign at the same time (when the system cannot accurately determine the conditional speed sign).
 - Displays a speed limit sign and a speed sign ahead at the same time.
 - Displays a speed limit sign and either a stop/do not enter/passing prohibited sign at the same time.





- Display of the TSR on the Active Driving Display can be disabled. Refer to the Settings section in the Mazda Connect Owner's Manual.

Speed limit signs (Including auxiliary signs) are displayed

When any of the following conditions is met, the speed limit sign  recognised by the system is displayed on the screen.

- The vehicle passes a recognised sign.
- The speed limit sign stored in the navigation system is read by the system while driving.

NOTE

- If the system cannot recognise a speed limit sign,  is displayed.
- If the system does not correctly recognise any conditional sign,  is displayed.
- If the system recognises a conditional speed sign such as time, weather, or zone, that sign is displayed.
- If the system recognises an implicit speed limit sign such as , , , that sign is displayed temporarily.
- **(Vehicles with navigation system)**
 - If the navigation system can determine the upcoming speed sign change, that speed limit sign and the remaining distance to it is displayed.*¹

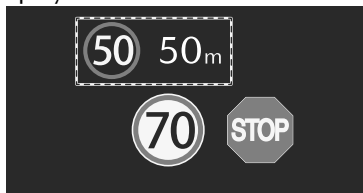

*¹ The remaining distance is displayed only in the instrument cluster (Type A).

A do not enter sign is displayed

If the system recognises a do not enter sign, the do not enter sign  is displayed on the screen.

NOTE

The screen display ends after a certain amount of time has passed since the vehicle passed the sign.

A stop sign is displayed

When your vehicle is travelling at a certain speed or slower, the stop sign  recognised by the system is displayed on the screen.

NOTE

The screen display ends after a certain period of time has passed since the sign was displayed on the screen.

A passing prohibited sign is displayed

When the system recognises a passing prohibited sign and the vehicle passes the sign, the passing prohibited sign  is displayed on the screen.

NOTE

- If any of the following conditions is met, the display of the passing prohibited sign ends.
 - The system recognises a passing prohibited end sign and the vehicle passes the sign.
 - A sign cannot be found even after travelling a certain distance after the vehicle has travelled on the same road.
 - The system determines that your vehicle has turned left or right.

Convenient Ways to Use the Traffic Sign Recognition System (TSR)

You can set an excessive speed warning to be issued when your vehicle's speed exceeds the speed indicated on the speed limit sign.

Turn on the excessive speed warning using Mazda Connect.
Refer to the Settings section in the Mazda Connect Owner's Manual.

If your vehicle's speed exceeds the speed on the speed limit sign, the area around the display of the speed limit sign flashes in amber  and a warning sound is activated. In addition, if the vehicle speed continues to be excessive, it stops flashing and remains on.

NOTE

The warning pattern and the warning activation timing can be changed using Mazda Connect.
Refer to the Settings section in the Mazda Connect Owner's Manual.

Distance & Speed Alert (DSA)*

The DSA is a system in which the screen display notifies the driver that the distance between your vehicle and a vehicle ahead is close.

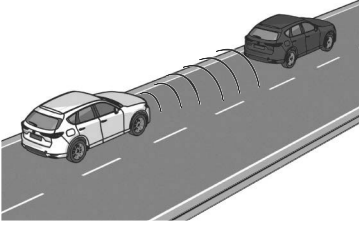

Warnings and Cautions for Using the Distance & Speed Alert (DSA)

WARNING

Do not rely completely on the DSA.

The DSA may not be able to detect a vehicle ahead depending on the type of vehicle ahead and its conditions, the weather conditions, and the road conditions. In addition, the system is not for maintaining the distance between your vehicle and a vehicle ahead. If you neglect to operate the accelerator and brake pedals correctly, it could lead to an accident.

Always check the surrounding conditions and depress the brake pedal or accelerator pedal while keeping a safe distance from a vehicle ahead or a vehicle following behind you.

How to Use the Distance & Speed Alert (DSA)

Operating the DSA

The DSA operates when all of the following conditions are met.

- The vehicle speed is about 30 km/h (19 mph) or faster.
- The system determines that the distance to the vehicle ahead is close.

When the DSA operates, the screen display notifies the driver that the distance between your vehicle and a vehicle ahead is close.

Instrument cluster (Type A)

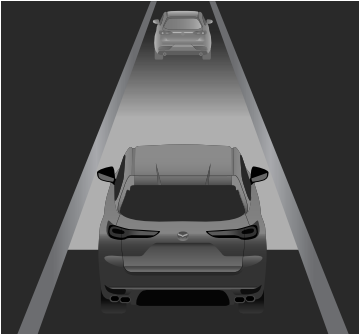

Instrument cluster (Type B)

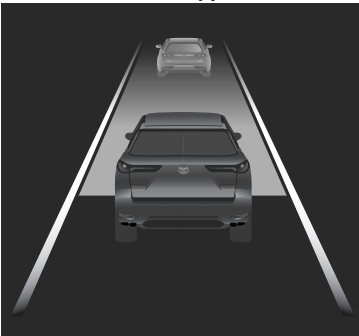

Active driving display



NOTE

- The objects which operate the DSA are four-wheeled vehicles. However, the DSA may also operate in the presence of motorcycles and bicycles.
- The DSA does not operate on stopped vehicles.
- When the speed of the vehicle ahead is extremely slow, the DSA may not operate normally.

Turning off the DSA

There are 2 ways to turn off the DSA.

- Turn off the DSA using Mazda Connect.
Refer to the Settings section in the Mazda Connect Owner's Manual.
- Turn off the DSA using the i-ACTIVSENSE OFF switch.
Refer to How to Use the i-ACTIVSENSE OFF switch on page 5-132.

Driver Attention Alert (DAA)

Driver Attention Alert (DAA)*

The DAA is a system that detects the driver fatigue and decreased attentiveness based on various types of vehicle information, and encourages the driver to take a rest using a screen display and warning sound.

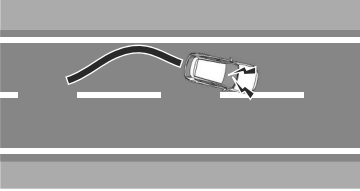

Warnings and Cautions for Using the Driver Attention Alert (DAA)

WARNING

Do not rely completely on the DAA.

The DAA does not prevent driver fatigue or decreased attentiveness and over reliance on the system could lead to an accident. Drive carefully and turn the steering wheel appropriately. In addition, the system may not be able to correctly detect driver fatigue or decreased attentiveness depending on the road and driving conditions. The driver must take sufficient rest in consideration of safe driving.

How to Use the Driver Attention Alert (DAA)

Operating the DAA

If all of the following conditions are met, the screen display and warning sound notify the driver that his/her attention level has decreased.

- The system has completed learning of the driver's driving data.
- The system detects white (yellow) lane lines.
- One hour has passed since the driver began driving.
- The vehicle speed is about 65 km/h to 140 km/h (41 mph to 86 mph).
- The system detects driver fatigue or decreased attentiveness

Instrument cluster (Type A)

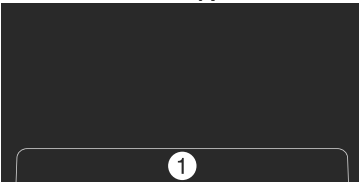

1. "Time for a Break"

Instrument cluster (Type B)

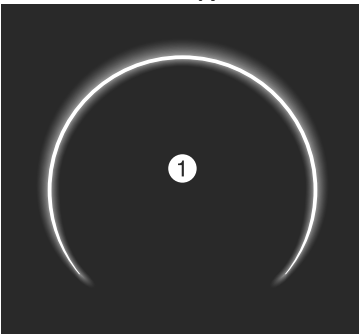

1. "Time for a Break"

NOTE

- The DAA does not operate if any of the following conditions is met.
 - The vehicle is making a sharp turn.
 - The vehicle is changing lanes.
- The DAA may not operate normally if any of the following conditions is met.
 - The visibility of white (yellow) lane lines is poor.
 - The vehicle is jolted or swayed continuously by strong winds or rough roads.
- The DAA detects driver fatigue and decreased attentiveness based on the driving data when driving the vehicle at a vehicle speed between about 65 km/h and about 140 km/h (41 to 86 mph) for about 20 minutes. The learned driving data is reset when any of the following conditions is met.
 - The vehicle is stopped for 15 minutes or longer.
 - The vehicle is driven at less than about 65 km/h (41 mph) for about 30 minutes.
 - The vehicle power is switched OFF.
- After the DAA has displayed the first message encouraging rest, it does not display the next one until 60 minutes have passed.

Turning off the DAA

Turn off the DAA using Mazda Connect.

Refer to the Settings section in the Mazda Connect Owner's Manual.

NOTE

(European models)

If the vehicle power is switched OFF with the DAA turned off, the DAA automatically turns on the next time the vehicle power is switched ON.

Driver Monitoring (DM)*

The DM is a system that detects dangerous conditions and behaviour of the driver and notifies the driver of possible danger.

The DM has two detection functions.

Drowsiness detection function

The drowsiness detection function detects the level of driver drowsiness. When the driver drowsiness is detected, the screen display and warning sound encourage the driver to take a rest.

There are 2 levels of screen display and warning sound.

Warning pattern (caution)

When driver drowsiness is detected, taking a rest is encouraged.

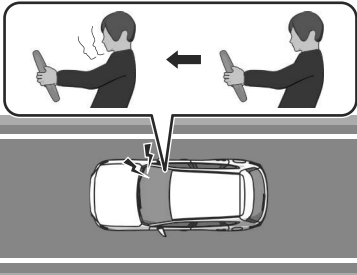

Warning pattern (warning)

If a higher level of driver drowsiness is detected, taking a rest is encouraged.

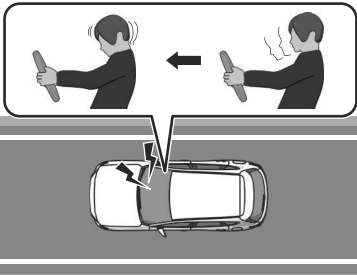

Inattentive driving detection function

The inattentive driving detection function detects that the driver is not paying attention to the road. When the system detects that the driver is not paying attention to the road, it alerts the driver with a screen display and a warning sound.

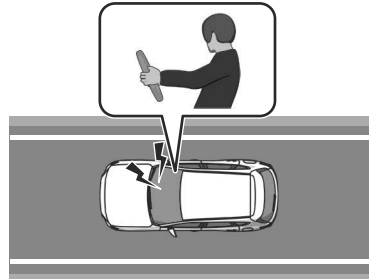

Warnings and Cautions for Using the Driver Monitoring (DM)

WARNING

Do not rely completely on the DM. The DM does not prevent driver drowsiness or inattentive driving and over reliance on the system could lead to an accident. Drive carefully and turn the steering wheel appropriately. In addition, the system may not be able to correctly detect driver drowsiness or inattentive driving depending on the road and driving conditions. The driver must take sufficient rest in consideration of safe driving.

How to Use the Driver Monitoring (DM)

Operating the drowsiness detection function

The drowsiness detection function operates when all of the following conditions are met.

- The vehicle has been driven for about 20 minutes or longer.
- The vehicle speed is about 5 km/h (3 mph) or faster.
- The system detects driver drowsiness.

When the drowsiness detection function operates, the screen display and warning sound encourage the driver to take a rest.

Instrument cluster (Type A)

Warning pattern (caution) (white)

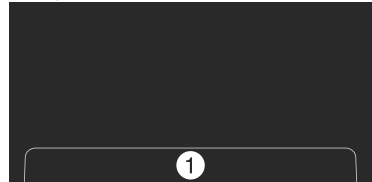

1. "Time for a Break"

Warning pattern (warning) (amber)

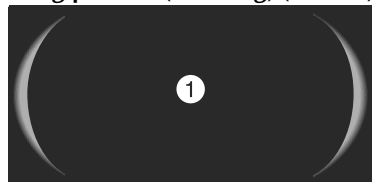

1. "Time for a Break"

Instrument cluster (Type B)

Warning pattern (caution) (white)

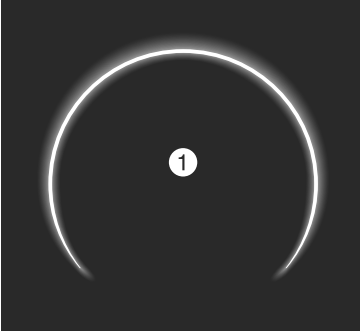

1. "Time for a Break"

Warning pattern (warning) (amber)



1. "Time for a Break"

NOTE

- After the drowsiness detection function has displayed the first message encouraging the driver to take a rest, it does not display it again during the following periods.
 - After displaying the warning pattern (caution), the next warning pattern (caution) is not displayed until 45 minutes have passed.

- After displaying the warning pattern (warning), the next warning pattern (warning) is not displayed until 15 minutes have passed.
- After displaying the warning pattern (warning), the next warning pattern (caution) is not displayed until 45 minutes have passed.
- If the driver monitoring camera does not recognise the driver correctly, the drowsiness detection function may not operate normally. Refer to Driver Monitoring Camera on page 5-145.
- The drowsiness detection function may not operate normally if any of the following conditions is met.
 - You are looking down.
 - You are squinting or closing your eyes.
 - One eye is closed.
 - You are laughing.

Operating the inattentive driving detection function

The inattentive driving detection function operates when all of the following conditions are met.

- The vehicle speed is about 30 km/h (19 mph) or faster.
- The system detects inattentive driving.

When the inattentive driving detection function operates, the screen display and warning sound alerts the driver.

Instrument cluster (Type A)

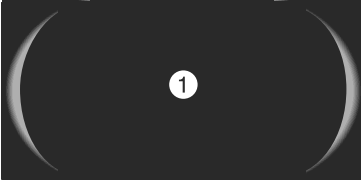

1. "Distracted Driver Detected"

Instrument cluster (Type B)

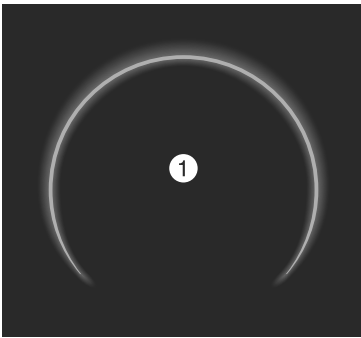

1. "Distracted Driver Detected"

NOTE

- If the driver monitoring camera does not recognise the driver correctly, the inattentive driving detection function may not operate normally. Refer to Driver Monitoring Camera on page 5-145.
- The inattentive driving detection function may not operate normally if any of the following conditions is met.
 - Your line of sight moves or directly after it stops moving
 - There is a large difference between your line of sight and the direction your face is pointed.
 - Your face or your eyes frequently turn in a direction other than straight ahead.

- You are driving the vehicle with your head largely tilted to one side.
- You are moving around extensively.

Turning off the DM

The DM can be turned off using the Mazda Connect.

Refer to the Settings section in the Mazda Connect Owner's Manual.

NOTE (European models)

If the vehicle power is switched OFF with the DM turned off, the DM automatically turns on the next time the vehicle power is switched ON.

Front Cross Traffic Alert (FCTA)

Front Cross Traffic Alert (FCTA)*

The FCTA assists the driver in checking both sides of the vehicle when the vehicle starts to drive at an intersection. When a vehicle approaching from the blind spots on the front left or right side is detected, a screen display and warning sound notify the driver of the danger.

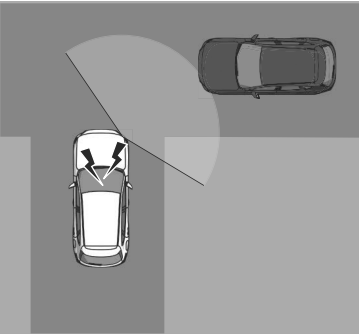

Warnings and Cautions for Using the Front Cross Traffic Alert (FCTA)

WARNING

Always check the surrounding area visually when the vehicle starts to drive at an intersection.

Due to certain limitations with the operation of the FCTA, the screen display and warning sound might be delayed even though there is a vehicle approaching from a blind spot. Always make it your responsibility as a driver to check the left and right sides.

How to Use the Front Cross Traffic Alert (FCTA)

Operating the FCTA

The FCTA operates when all of the following conditions are met.

- The vehicle speed is less than about 10 km/h (6 mph).
- The selector lever is in the D position.
- The system detects a vehicle approaching at a speed of about 5 km/h (3 mph) or faster from the front side of your vehicle.

When the FCTA is operating, the driver is notified of the danger by the screen display and the warning sound according to the situation.

When your vehicle is stopped

The screen display (white)^{*1} notifies you that a vehicle is approaching.

Instrument cluster (Type A)

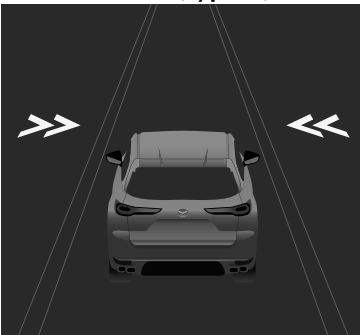

Instrument cluster (Type B)

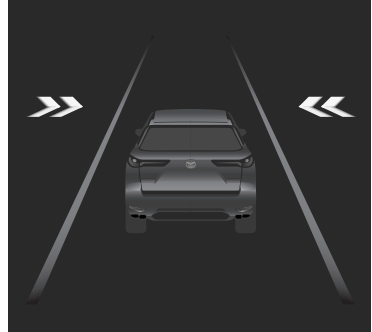

Active driving display



360° view monitor



*1 The instrument cluster screen display (white) is displayed only when the instrument cluster is set to the i-ACTIVSENSE display.

When your vehicle is moving

The screen display (amber) and warning sound notify the driver of the possibility that a collision may occur with an approaching vehicle.

Instrument cluster (Type A)

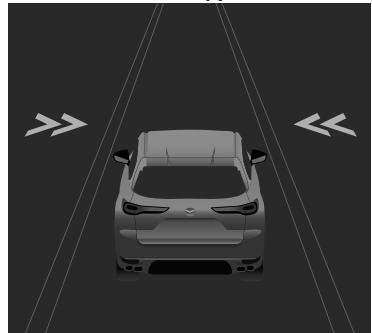

Front Cross Traffic Alert (FCTA)

Instrument cluster (Type B)

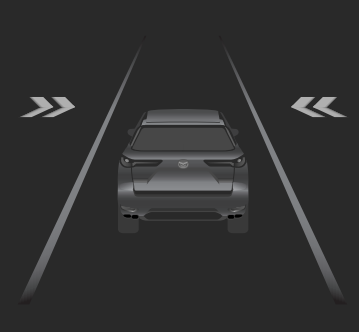

Active driving display



360° view monitor



NOTE

- The system may operate even if a vehicle is not approaching depending on the conditions around your vehicle.
- The front side radar sensors may not detect objects and the front cross traffic alert (FCTA) may not operate normally.
Refer to Radar Sensors on page 5-137.

Turning off the FCTA

There are 2 ways to turn off the FCTA.

- Turn off the FCTA using Mazda Connect.
Refer to the Settings section in the Mazda Connect Owner's Manual.
- Turn off the FCTA using the i-ACTIVSENSE OFF switch.
Refer to How to Use the i-ACTIVSENSE OFF switch on page 5-132.

Rear Cross Traffic Alert (RCTA)*

The RCTA assists the driver in checking the area to the rear of the vehicle, such as while reversing out of a parking space. When a vehicle approaching from the rear on the left or right is detected, various screen displays and warning sounds notify the driver of the danger.

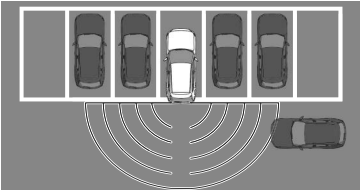

Warnings and Cautions for Using the Rear Cross Traffic Alert (RCTA)

WARNING

Do not rely completely on the RCTA. The RCTA is a system to assist the driver in checking the area to the rear of the vehicle while reversing. Due to certain limitations with the operation of the system, the BSM warning light may not flash or it might be delayed even though a vehicle is at the rear of your vehicle. Always make it your responsibility as a driver to check the rear.

How to Use the Rear Cross Traffic Alert (RCTA)

Operating the RCTA

The RCTA operates when all of the following conditions are met.

- The vehicle is about to be driven in reverse.
- The system detects an approaching vehicle.

When the RCTA operates, the driver is notified of the danger by flashing of the BSM warning lights, a warning indication, and a warning sound.

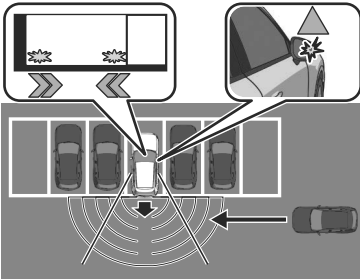

NOTE

- The system may operate even if a vehicle is not approaching depending on the conditions around your vehicle.
- The RCTA may not operate normally if any of the following conditions is met.
 - The rear side radar sensors cannot detect an object. Refer to Radar Sensors on page 5-137.
 - The vehicle speed when reversing is about 15 km/h (9 mph) or faster.
 - A vehicle is approaching directly from the rear of your vehicle.
 - A vehicle is approaching at an angle from the rear of your vehicle.

- If a Mazda genuine trailer hitch is used, the RCTA is automatically turned off when the trailer's electrical connector is connected.
- When pulling a trailer other than with a Mazda genuine trailer hitch, or while an accessory such as a bicycle carrier is installed to the rear of the vehicle, turn off the RCTA. Otherwise, the radar's radio waves will be blocked causing the RCTA to not operate normally.
- The brightness of the BSM warning lights is linked to the panel light control. Refer to Instrument Panel Illumination on page 5-32.

Turning off the RCTA

There are 2 ways to turn off the RCTA.

- Turn off the RCTA using Mazda Connect. Refer to the Settings section in the Mazda Connect Owner's Manual.
- Turn off the RCTA using the i-ACTIVSENSE OFF switch. Refer to How to Use the i-ACTIVSENSE OFF switch on page 5-132.

Mazda Radar Cruise Control (MRCC)*

MRCC is a system that reduces load on the driver through constant speed and headway control. The function performs headway control to maintain the distance with a vehicle ahead at a constant preset speed without you having to depress the accelerator or brake pedal.

Warnings and Cautions for Using the Mazda Radar Cruise Control (MRCC)

WARNING

Do not rely completely on the MRCC. The MRCC may not be able to detect a vehicle ahead depending on the type of vehicle ahead and its conditions, the weather conditions, and the road conditions. Additionally, the system might be unable to decelerate sufficiently if the vehicle ahead applies the brakes suddenly or another vehicle cuts into your lane, which could result in an accident.

Always check the surrounding conditions and depress the brake pedal or accelerator pedal while keeping a safe distance from a vehicle ahead or a vehicle following behind you.

Do not use the MRCC under the following conditions. Otherwise, it may result in an accident.

- The vehicle is driven on roads other than highways.
- The vehicle is driven on roads with sharp curves or with heavy traffic where sufficient distances between vehicles cannot be kept.
- The vehicle is driven on roads where acceleration and deceleration are frequently repeated.
- The vehicle is exiting the main lane on an expressway to enter an interchange, a rest area, or a parking area.

- The vehicle is driven on slippery roads such as icy roads, snow-covered roads, and unpaved roads.
- The vehicle is driven on a long downslope.
- The vehicle is driven on a steep slope.
- A two-wheeled vehicle such as a motorcycle or bicycle is travelling ahead.

Switch the MRCC off when it is not being used.

Leaving the MRCC on when it is not in use is dangerous as it could operate unexpectedly, resulting in an accident.

Do not leave the vehicle while the vehicle is stopped by the MRCC control. (Only with Stop & Go function)

Getting out of the vehicle while the stop hold control is operating is dangerous as the vehicle may move unexpectedly and result in an accident. Before leaving the vehicle, switch the MRCC off, shift the selector lever to the P position, and apply the parking brake.

 **CAUTION**

- If the vehicle is towed or you are towing something, switch the MRCC off.
- Turn off the MRCC when the vehicle is running on a chassis roller.

How to Use the Mazda Radar Cruise Control (MRCC)

MRCC operation conditions

The MRCC can be set when all of the following conditions are met.

(Except with Stop & Go function)

- The brake pedal is not depressed.
- The vehicle speed is as follows:
 - **(European models)**
About 30 km/h (19 mph) to 200 km/h (125 mph).
 - **(Except European models)**
About 30 km/h (19 mph) to 145 km/h (90 mph).
- The Hill Descent Control is not operating.

(With Stop & Go function)

- The brake pedal is not depressed.
- The vehicle speed is as follows:
 - **(European models)**
About 0 km/h (0 mph) to 200 km/h (125 mph).
 - **(Except European models)**
About 0 km/h (0 mph) to 145 km/h (90 mph).
- The Hill Descent Control is not operating.

Setting the MRCC

1. Press the MRCC switch to turn the system on.

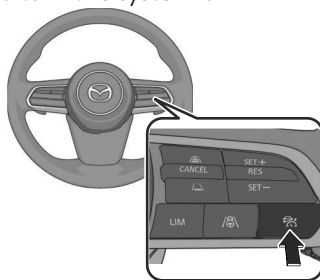



When the system is on, the MRCC standby indication (white)  is displayed on the screen.

2. Accelerate to the desired speed.

Mazda Radar Cruise Control (MRCC)

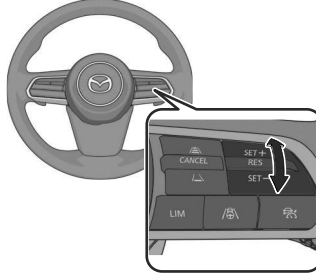
3. Set the vehicle speed by pressing the RES switch up (SET+) or down (SET-).



Constant speed driving starts when the vehicle speed is set. In addition, the set speed is displayed on the screen, and the MRCC standby indication (white)  changes to the MRCC set indication (green) .



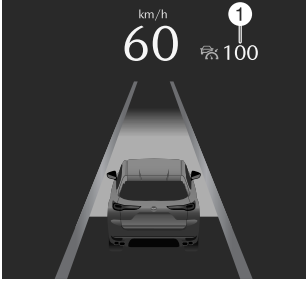
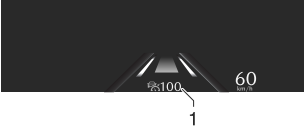
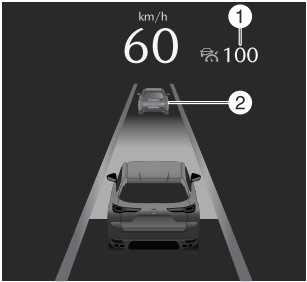
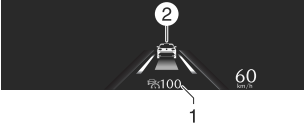

If a vehicle ahead is detected while travelling at a constant speed, the system switches to headway control. The vehicle ahead indication is displayed on the screen while in headway control.

Instrument cluster (Type A)

Driving condition	Instrument cluster display	Active driving display indication
During travel at constant speed		
During travel under headway control		

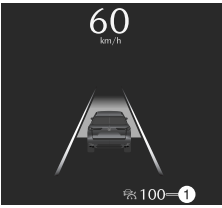
1. Set speed
2. Vehicle ahead indication

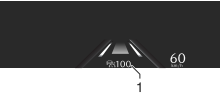
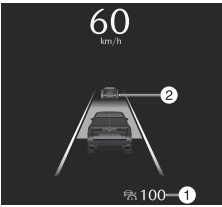
Instrument cluster (Type B)

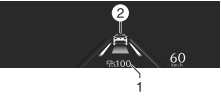
Driving condition	Instrument cluster display		Active driving display indication
	i-ACTIVSENSE display	Other than i-ACTIVSENSE display	
During travel at constant speed			
During travel under headway control			

1. Set speed
2. Vehicle ahead indication

NOTE

- If there is a structure on the road or an obstruction at a low height off the ground in front of the vehicle, the system may recognise it as a vehicle ahead.
 - Acceleration and deceleration by accelerator pedal operation takes priority while travelling at a constant speed or in headway control. When the accelerator pedal is released, the vehicle returns to driving at a constant speed or headway control at the set speed.
 - If a vehicle ahead is travelling at an extremely low speed, the system may not detect it correctly.
 - While driving using the MRCC, intended engine braking is not applied even if the selector lever is operated.
 - The brake lights turn on while the brakes are operating by the MRCC control.
 - The MRCC is also turned off automatically when the vehicle power is switched OFF.
 - If the distance between vehicles control is disabled using Mazda Connect, the system switches to the cruise control. At this time, the MRCC switch functions as the cruise control switch.
Refer to the Settings section in the Mazda Connect Owner's Manual.
- If the vehicle power is switched OFF while the distance between vehicles control is disabled, the distance between vehicles control is enabled automatically the next time the vehicle power is switched ON.

(With Stop & Go function)

If the vehicle ahead stops during headway control, your vehicle in headway control also stops. When the vehicle is stopped, the MRCC indicator light **HOLD** in the instrument cluster turns on.

When the vehicle ahead accelerates from a stop and one of the following operations is performed, your vehicle starts driving.

- Press the RES switch.
- Depress the accelerator pedal.

If you do not start driving the vehicle after the vehicle ahead has resumed driving, the system urges the driver to resume driving.

NOTE

- If the vehicle ahead resumes driving within 3 seconds after the vehicle was stopped by the system, your vehicle also resumes driving automatically.
- If the vehicle is stopped by the system continuously for 10 minutes or longer, the parking brake is applied automatically. At this time, the MRCC is cancelled.
- Even if the MRCC is cancelled while the vehicle is stopped, the vehicle is held in its stopped position.

Refer to AUTOHOLD on page 5-73.

- If the MRCC is cancelled while the vehicle is stopped and there is no vehicle ahead, you cannot resume driving the vehicle using the RES switch. Depress the accelerator pedal and start driving the vehicle.
 - If the i-stop operation conditions are met while the vehicle is stopped, the i-stop function operates without depressing the brake pedal. The engine restarts automatically when you start driving the vehicle.
- Refer to i-stop on page 5-23.

Changing the set vehicle speed

NOTE

- (European models)

The system automatically provides more acceleration when operating the direction indicator to switch to the passing lane. Drive with caution as your vehicle may be too close to the vehicle ahead.

Changing the set vehicle speed using the RES switch

Press the RES switch up (SET+) or down (SET-) to the desired speed.

- Press and release immediately: 1 km/h (1 mph)
- Press and hold: 10 km/h (5 mph)

Changing the set vehicle speed using the accelerator pedal

Depress the accelerator pedal until the vehicle speed reaches the desired speed, then press the RES switch up (SET+) or down (SET-).

Reading the set vehicle speed from the speed limit sign using the RES switch (Speed Limit Assist only)

Press the RES switch when the speed limit sign set indication **RES** turns on.

! CAUTION

- The function which recognises speed limit signs has limitations. Always check the set vehicle speed that was read.
- Set the speedometer display unit to the same unit as the speed limit sign. Differing units will capture speeds not intended by the driver.

NOTE

- The Speed Limit Assist operates only when the navigation system's SD card is inserted.
- The Speed Limit Assist uses the Traffic Sign Recognition system (TSR). Refer to Traffic Sign Recognition System (TSR) on page 5-163.
- The Speed Limit Assist cannot read speeds of less than 30 km/h (19 mph).
- Set vehicle speeds read from speed limit signs can be adjusted. Refer to the Settings section in the Mazda Connect Owner's Manual.
- The Speed Limit Assist can be turned off. Refer to the Settings section in the Mazda Connect Owner's Manual.





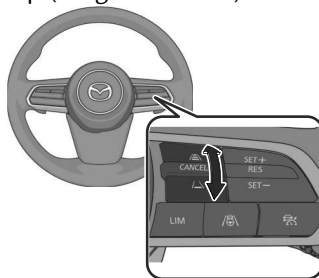



Setting the distance-between-vehicles during headway control

1. Press the CANCEL switch up (longer distance) or down (shorter distance).



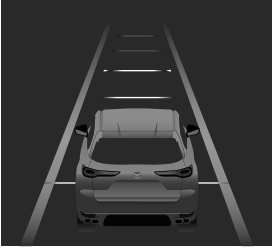

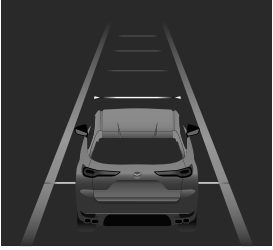



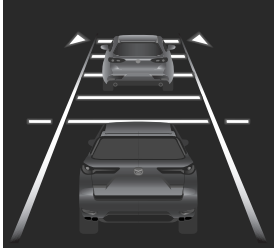

MRCC is not operating (white)

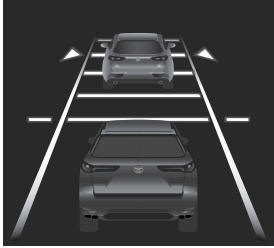
Instrument cluster (Type A)

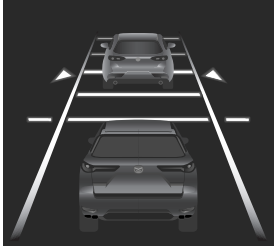

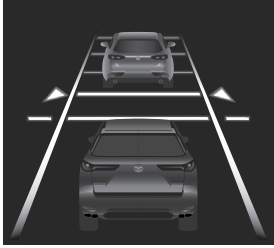



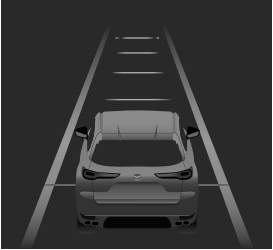

Distance-between-vehicles guideline (at 80 km/h (50 mph) vehicle speed)	Instrument cluster display	Active driving display indication
Long (about 50 m (164 ft))		
Medium (about 40 m (131 ft))		
Short (about 30 m (98 ft))		
Extremely short (about 25 m (82 ft))		

Instrument cluster (Type B)



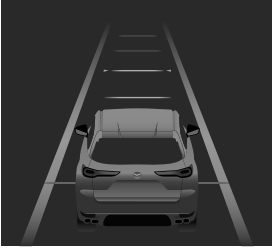

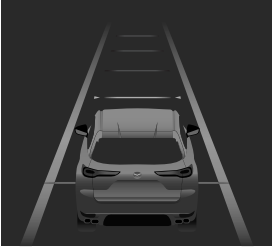

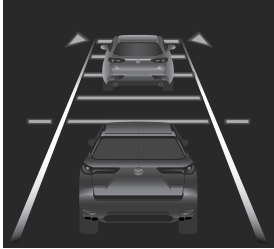

Distance-between-vehicles guide-line (at 80 km/h (50 mph) vehicle speed)	Instrument cluster display	Active driving display indication
Long (about 50 m (164 ft))		
Medium (about 40 m (131 ft))		
Short (about 30 m (98 ft))		
Extremely short (about 25 m (82 ft))		

MRCC is operating (green)

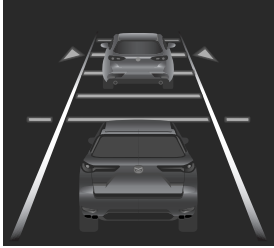
Instrument cluster (Type A)

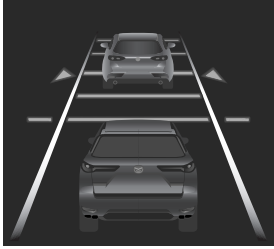
Distance-between-vehicles guide-line (at 80 km/h (50 mph) vehicle speed)	Instrument cluster display	Active driving display indication
Long (about 50 m (164 ft))		
Medium (about 40 m (131 ft))		
Short (about 30 m (98 ft))		
Extremely short (about 25 m (82 ft))		

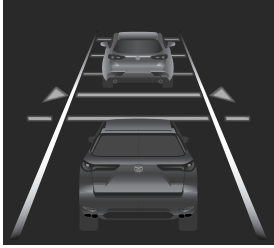
Instrument cluster (Type B)

Distance-between-vehicles guide-line (at 80 km/h (50 mph) vehicle speed)	Instrument cluster display	Active driving display indication
Long (about 50 m (164 ft))		
Medium (about 40 m (131 ft))		
Short (about 30 m (98 ft))		
Extremely short (about 25 m (82 ft))		

NOTE

- The distance-between-vehicles can be set to 4 levels: Long, medium, short, and extremely short distance.
- The distance-between-vehicles differs depending on the vehicle speed, and the slower the vehicle speed, the shorter the distance.

Close proximity warning

If your vehicle approaches a vehicle ahead while in headway control, a warning sound and a display cautions you.

Instrument cluster (Type A)

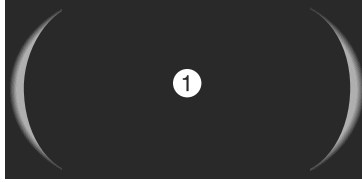

1. "Depress Brake Pedal"

Instrument cluster (Type B)

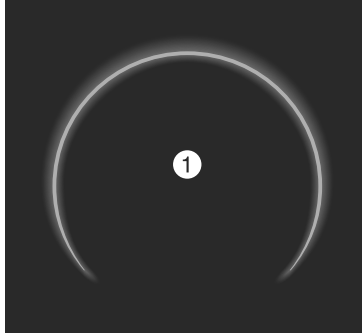

1. "Depress Brake Pedal"

NOTE

The close proximity warning may not be activated in the following cases.

- The vehicle is driven at the same speed as the vehicle ahead.
- Directly after the MRCC is set.
- Immediately after the accelerator pedal is released.
- Another vehicle cuts into the driving lane.
- Do not use the MRCC under conditions in which the close proximity warnings are frequently activated.

The MRCC is cancelled temporarily

If any of the following conditions is met, the MRCC is cancelled temporarily.

- The brake pedal is depressed.
- The CANCEL switch is pressed one time.
- The DSC has operated.
- The Smart Brake Support (SBS) has operated.
- The front radar sensors cannot detect target objects.
- The parking brake is applied.
- Any door is opened.
- The driver's seat belt is unfastened.
- The frequency of the braking operation by the MRCC is high.

If the MRCC is temporarily cancelled, it will resume operation at the previously set speed by pressing the RES switch.

Turning off the MRCC

Press the MRCC switch.

The MRCC set indication (green)  / MRCC standby indication (white)  turns off, and the MRCC turns off.

Cruising & Traffic Support (CTS)*

The CTS is a system that reduces the load on the driver while the vehicle is driven on expressways or highways. The CTS has the following 2 functions.

Constant speed/Headway control function

The function performs headway control to maintain the distance with a vehicle ahead at a constant preset speed without you having to depress the accelerator or brake pedal.

Steering wheel assist function

When vehicle lane lines are detected, the function assists your steering wheel operation to follow the vehicle lane lines.

When vehicle lane lines are not detected, the function assists your steering wheel operation to follow the trajectory of the vehicle ahead.

Warnings and Cautions for Using Cruising & Traffic Support (CTS)

WARNING

Do not rely completely on the CTS.

- The CTS is not an automated driving system. Therefore, the function has limitations. Do not rely completely on the system and always stay on course using the steering wheel.
- Set a vehicle speed within the speed limit according to the road conditions and the weather conditions.
- The CTS may not be able to detect a vehicle ahead depending on the type of vehicle ahead and its conditions, the weather conditions, and the road conditions. Additionally, the system might be unable to decelerate sufficiently if the vehicle ahead applies the brakes suddenly or another vehicle cuts into your lane, which could result in an accident.

Do not use the CTS under the following conditions. Otherwise, it may result in an accident.

- The vehicle is driven on roads other than expressways and highways.
- The vehicle is driven on roads with sharp curves or with heavy traffic where sufficient distances between vehicles cannot be kept.
- The vehicle is driven on roads where acceleration and deceleration are frequently repeated.
- The vehicle is exiting the main lane on an expressway to enter an interchange, a rest area, or a parking area.

- The vehicle is driven on slippery roads such as icy roads, snow-covered roads, and unpaved roads.
- The vehicle is driven on a long downslope.
- The vehicle is driven on a steep slope.
- A two-wheeled vehicle such as a motorcycle or bicycle is travelling ahead.
- The vehicle is being towed or towing another vehicle.
- Proximity warnings activate frequently.
- Under bad weather conditions (rain, fog, and snow).
- Tyres other than the specified size are used, such as when tyre chains or temporary spare tyres are used.
- The tyre pressures are not adjusted to the appropriate pressure.
- Tyres with insufficient tread are used.

Switch the CTS off when it is not being used.

Leaving the CTS on when it is not in use is dangerous as it could operate unexpectedly, resulting in an accident.

Do not leave the vehicle while the vehicle is stopped by the CTS control. (Only vehicles with Mazda Radar Cruise Control with Stop & Go function)

Getting out of the vehicle while the stop hold control is operating is dangerous as the vehicle may move unexpectedly and result in an accident. Before leaving the vehicle, switch the CTS off, shift the selector lever to the P position, and apply the parking brake.

 **CAUTION**

- Heed the following cautions so that the CTS can operate normally.
 - Do not modify the suspensions.
 - Always use wheels of the specified size for the front and rear wheels. Consult an expert repairer (we recommend an Authorised Mazda Repairer) for tyre replacement.
- Turn off the CTS when the vehicle is running on a chassis roller.

How to Use the Cruising & Traffic Support (CTS)

CTS operation conditions

The CTS speed can be set when all of the following conditions are met.

(Vehicles with Mazda Radar Cruise Control)

- The brake pedal is not depressed.
- The vehicle speed is as follows:
 - **(European models)**
About 30 km/h (19 mph) to 200 km/h (125 mph).
 - **(Except European models)**
About 30 km/h (19 mph) to 145 km/h (90 mph).
- The Hill Descent Control is not operating.
- The Mazda Radar Cruise Control is available.

(Vehicles with Mazda Radar Cruise Control with Stop & Go function)

- The brake pedal is not depressed.
- The vehicle speed is as follows:
 - **(European models)**
About 0 km/h (0 mph) to 200 km/h (125 mph).
 - **(Except European models)**
About 0 km/h (0 mph) to 145 km/h (90 mph).
- The Hill Descent Control is not operating.
- The Mazda Radar Cruise Control is available.

Setting the CTS

1. Press the CTS switch to turn the system on.

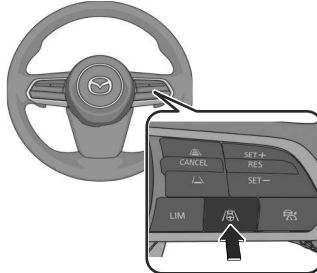



When the system is on, the CTS standby indication (white)  is displayed on the screen.

2. Accelerate to the desired speed.

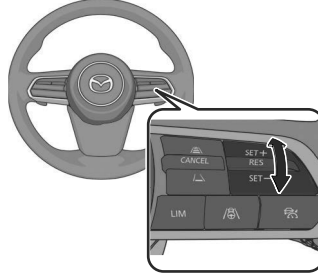
3. Set the vehicle speed by pressing the RES switch up (SET+) or down (SET-).



Constant speed driving starts when the vehicle speed is set. In addition, the set speed is displayed on the screen, and the CTS standby indication (white)  changes to the CTS set indication (green) .



If a vehicle ahead is detected while travelling at a constant speed, the system switches to headway control. The vehicle ahead indication is displayed on the screen while in headway control.

Instrument cluster (Type A)

Driving condition	Instrument cluster display	Active driving display indication
During travel at constant speed		
During travel under headway control		

1. Set speed
2. Vehicle ahead indication

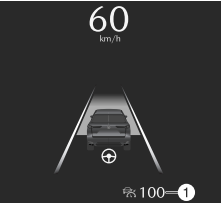
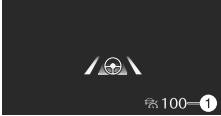
Instrument cluster (Type B)

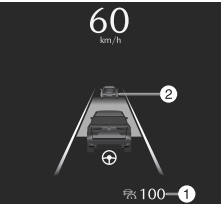
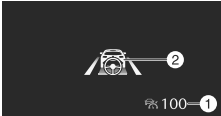
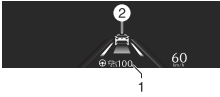
Driving condition	Instrument cluster display		Active driving display indication
	i-ACTIVSENSE display	Other than i-ACTIVSENSE display	
During travel at constant speed			
During travel under headway control			

1. Set speed
2. Vehicle ahead indication

NOTE

- If there is a structure on the road or an obstruction at a low height off the ground in front of the vehicle, the system may recognise it as a vehicle ahead.
- Acceleration and deceleration by accelerator pedal operation takes priority while travelling at a constant speed or in headway control. When the accelerator pedal is released, the vehicle returns to driving at a constant speed or headway control at the set speed.
- The Forward Sensing Camera (FSC) may not be able to detect target objects correctly, and the CTS may not operate normally. Refer to Forward Sensing Camera (FSC) on page 5-133.
- If a vehicle ahead is travelling at an extremely low speed, the system may not detect it correctly.
- While driving using the CTS, intended engine braking is not applied even if the selector lever is operated.
- The brake lights turn on while the brakes are operating by the CTS control.

The steering assist function operates if all of the following conditions are met while travelling at a constant speed or in headway control.





- The vehicle is driven at a vehicle speed slower than about 150 km/h (94 mph) near the centre of the lane and the white (yellow) lane lines on both sides are

detected clearly, or the vehicle is driven at a vehicle speed slower than about 50 km/h (31 mph) and a vehicle ahead is detected clearly in front of your vehicle.



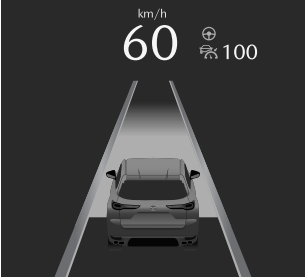

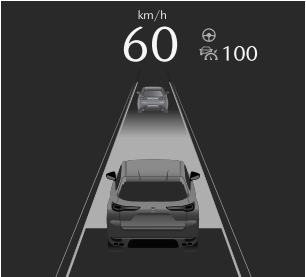
- The steering wheel is not turned sharply.
- The direction indicator lever is not operated.
- **(Vehicles with Mazda Radar Cruise Control)**
 The vehicle speed is about 30 km/h (19 mph).

When the steering assist function operates, the steering assist operation display changes from white to green.

Instrument cluster (Type A)

Driving condition	Instrument cluster display	Active driving display indication
Steering assist within vehicle lane lines		
Steering assist along the trajectory of the vehicle ahead		

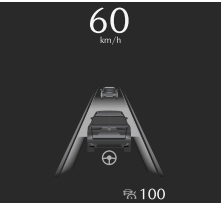
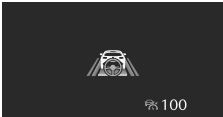
Instrument cluster (Type B)

Driving condition	Instrument cluster display		Active driving display indication
	i-ACTIVSENSE display	Except i-ACTIVSENSE display	
Steering assist within vehicle lane lines			
Steering assist along the trajectory of the vehicle ahead			

NOTE

- The steering assist function assists the steering wheel operation so that the vehicle remains near the centre of the driving lane, however, the function might not be able to keep the vehicle near the centre of the driving lane when any of the following conditions is met.
 - The vehicle speed is high.
 - The vehicle is making a sharp turn.
 - The vehicle is driven on a road with steep or up and down (wavy) slopes.
 - The vehicle is driven on a road with a large lateral gradient.
- If you take your hands off the steering wheel, a warning (amber) is indicated on the instrument cluster and the active driving display. Then, if you continue to leave your hands off the steering wheel, a warning (red) is indicated on the instrument cluster and the active driving display and a warning sound is activated.

Instrument cluster (Type A)
Warning (amber)

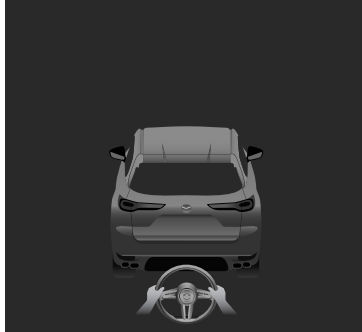

Warning (red)

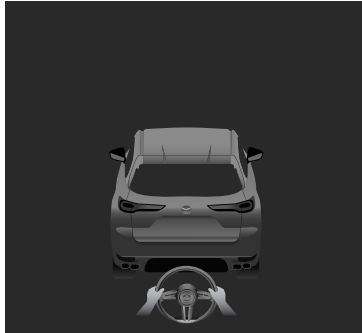

Instrument cluster (Type B)
Warning (amber)

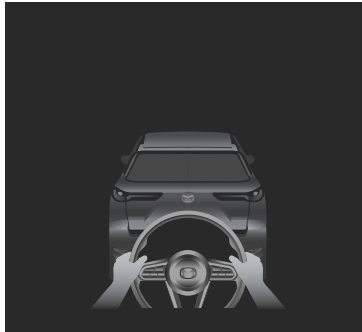

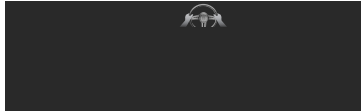
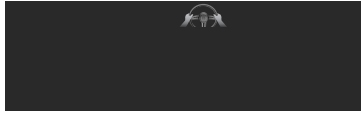
Warning (red)**Active driving display
Warning (amber)****Warning (red)****(Vehicles with Mazda Radar Cruise Control with Stop & Go function)**

If the vehicle ahead stops during headway control, your vehicle in headway control also stops. While the vehicle is stopped, the CTS indicator light **HOLD** in the Instrument cluster turns on.

When the vehicle ahead accelerates from a stop and one of the following operations is performed, your vehicle starts driving.

- Press the RES switch.
- Depress the accelerator pedal.

If you do not start driving the vehicle after the vehicle ahead has resumed driving, the system urges the driver to resume driving.

NOTE

- If the vehicle ahead resumes driving within 3 seconds after the vehicle was stopped by the system, your vehicle also resumes driving automatically.
 - If the vehicle is stopped by the system continuously for 10 minutes or longer, the parking brake is applied automatically. At this time, the CTS is cancelled.
 - Even if the CTS is cancelled while the vehicle is stopped, the vehicle is held in its stopped position.
- Refer to AUTOHOLD on page 5-73.

- If the CTS is cancelled while the vehicle is stopped and there is no vehicle ahead, you cannot resume driving the vehicle using the RES switch. Depress the accelerator pedal and start driving the vehicle.
- If the i-stop operation conditions are met while the vehicle is stopped, the i-stop function operates without depressing the brake pedal. The engine restarts automatically when you start driving the vehicle.
Refer to i-stop on page 5-23.

Changing the set vehicle speed

NOTE

- **(European models)**
The system automatically provides more acceleration when operating the direction indicator to switch to the passing lane. Drive with caution as your vehicle may be too close to the vehicle ahead.

Changing the set vehicle speed using the RES switch

Press the RES switch up (SET+) or down (SET-) to the desired speed.

- Press and release immediately: 1 km/h (1 mph)
- Press and hold: 10 km/h (5 mph)

Changing the set vehicle speed using the accelerator pedal

Depress the accelerator pedal until the vehicle speed reaches the desired speed, then press the RES switch up (SET+) or down (SET-).

Reading the set vehicle speed from the speed limit sign using the RES switch (Speed Limit Assist only)

Press the RES switch when the speed limit sign set indication  turns on.



- The function which recognises speed limit signs has limitations. Always check the set vehicle speed that was read.
- Set the speedometer display unit to the same unit as the speed limit sign. Differing units will capture speeds not intended by the driver.

NOTE

- The Speed Limit Assist operates only when the navigation system's SD card is inserted.
- The Speed Limit Assist uses the Traffic Sign Recognition system (TSR).
Refer to Traffic Sign Recognition System (TSR) on page 5-163.
- The Speed Limit Assist cannot read speeds of less than 30 km/h (19 mph).
- Set vehicle speeds read from speed limit signs can be adjusted.
Refer to the Settings section in the Mazda Connect Owner's Manual.
- The Speed Limit Assist can be turned off.

Cruising & Traffic Support (CTS)

Refer to the Settings section in the Mazda Connect Owner's Manual.





Setting the distance-between-vehicles during headway control

1. Press the CANCEL switch up (longer distance) or down (shorter distance).





CTS is not operating (white) Instrument cluster (Type A)





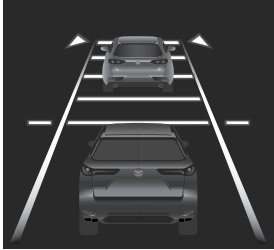

Distance-between-vehicles guideline (at 80 km/h (50 mph) vehicle speed)	Instrument cluster display	Active driving display indication
Long (about 50 m (164 ft))		
Medium (about 40 m (131 ft))		

Distance-between-vehicles guideline (at 80 km/h (50 mph) vehicle speed)	Instrument cluster display	Active driving display indication
Short (about 30 m (98 ft))		
Extremely short (about 25 m (82 ft))		

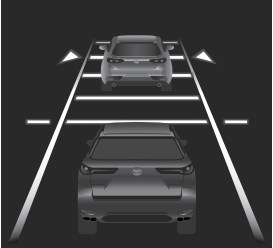
Instrument cluster (Type B)

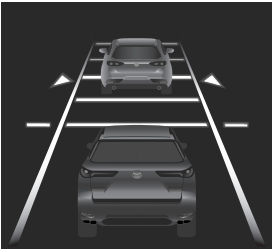

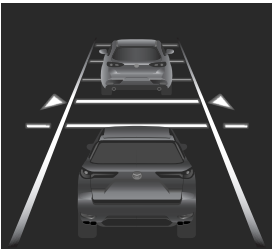



Distance-between-vehicles guideline (at 80 km/h (50 mph) vehicle speed)	Instrument cluster display	Active driving display indication
Long (about 50 m (164 ft))		

Driving
Cruising & Traffic Support (CTS)



Distance-between-vehicles guide-line (at 80 km/h (50 mph) vehicle speed)	Instrument cluster display	Active driving display indication
Medium (about 40 m (131 ft))		
Short (about 30 m (98 ft))		
Extremely short (about 25 m (82 ft))		

CTS is operating (green)





Instrument cluster (Type A)



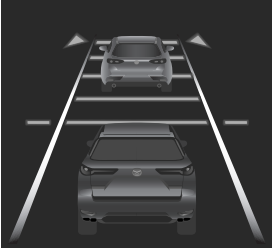

Distance-between-vehicles guideline (at 80 km/h (50 mph) vehicle speed)	Instrument cluster display	Active driving display indication
Long (about 50 m (164 ft))		
Medium (about 40 m (131 ft))		
Short (about 30 m (98 ft))		

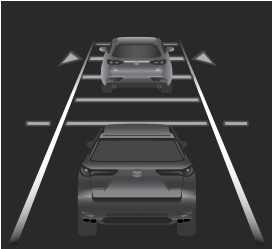
Cruising & Traffic Support (CTS)

Distance-between-vehicles guideline (at 80 km/h (50 mph) vehicle speed)	Instrument cluster display	Active driving display indication
Extremely short (about 25 m (82 ft))		

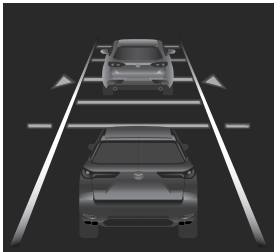
Instrument cluster (Type B)

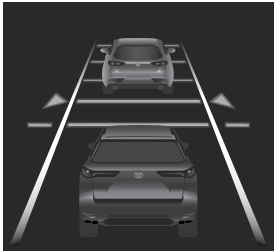
Distance-between-vehicles guideline (at 80 km/h (50 mph) vehicle speed)	Instrument cluster display	Active driving display indication
Long (about 50 m (164 ft))		
Medium (about 40 m (131 ft))		

Distance-between-vehicles guide-line (at 80 km/h (50 mph) vehicle speed)	Instrument cluster display	Active driving display indication
Short (about 30 m (98 ft))		
Extremely short (about 25 m (82 ft))		

NOTE

- The distance-between-vehicles can be set to 4 levels: Long, medium, short, and extremely short distance.
- The distance-between-vehicles differs depending on the vehicle speed, and the slower the vehicle speed, the shorter the distance.

Close proximity warning

If your vehicle approaches a vehicle ahead while in headway control, a warning sound and a display cautions you.

Instrument cluster (Type A)

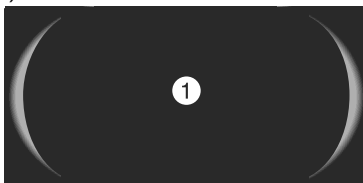

1. “Depress Brake Pedal”

Instrument cluster (Type B)

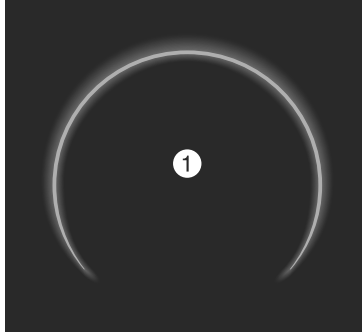

1. "Depress Brake Pedal"

NOTE

- The close proximity warning may not be activated in the following cases.
 - The vehicle is driven at the same speed as the vehicle ahead.
 - Directly after the CTS is set.
 - Immediately after the accelerator pedal is released.
 - Another vehicle cuts into the driving lane.
- Do not use the CTS system under conditions in which the close proximity warnings are frequently activated.

Steering assist limit warning

If the steering assist function cannot keep the vehicle within the lane lines, a screen display and a warning sound urge you to operate the steering wheel.

Instrument cluster (Type A)

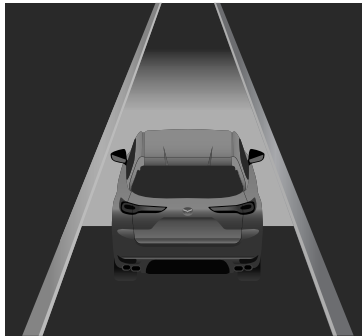

Instrument cluster (Type B)

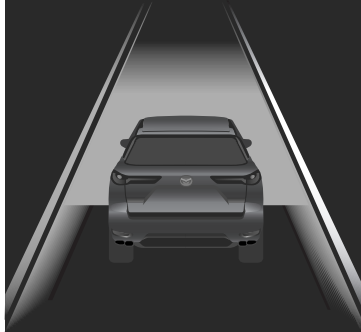

Active driving display



The CTS is temporarily cancelled

Constant speed/Headway control function

If any of the following conditions is met, the constant speed/headway control function is temporarily cancelled.

- The brake pedal is depressed.
- The CANCEL switch is pressed one time.
- The DSC has operated.
- The Smart Brake Support (SBS) has operated.
- The front radar sensors cannot detect target objects.
- The parking brake is applied.
- Any door is opened.
- The driver's seat belt is unfastened.
- The frequency of the braking operation by the CTS is high.

If the constant speed/headway control function is temporarily cancelled, it will resume operation at the previously set speed by pressing the RES switch.

Steering assist function

If any of the following conditions is met, the steering assist function is temporarily cancelled. The steering assist function is automatically restored when its operation conditions are met.

- The constant speed/headway control function is cancelled.
- White (yellow) lane lines cannot be detected or a vehicle ahead cannot be recognised.
- **(European models)**

Cruising & Traffic Support (CTS)

The vehicle speed is about 150 km/h (94 mph) or faster.

- The direction indicator lever is operated.
- The steering wheel is operated abruptly.
- Hands are off the steering wheel.
- The vehicle is making a sharp curve.
- The vehicle crosses a lane line.
- The width of the vehicle lane is narrow or wide.

NOTE

The notification method when the steering assist function is cancelled can be changed.

Refer to the Settings section in the Mazda Connect Owner's Manual.

Turning off the CTS

Press the CTS switch.

The CTS set indication (green) /CTS standby indication (white)  turns off, and the CTS turns off.

Lane-keep Assist System (LAS)*

The LAS is a system to help the driver stay within the vehicle lane if the vehicle might be deviating. If your vehicle may be deviating from the vehicle lane, the LAS provides steering assistance to avoid departure from the lane.

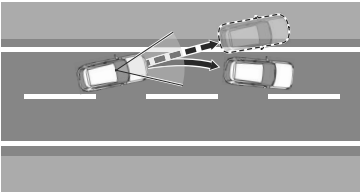

Warnings and Cautions for Using the Lane-keep Assist System (LAS)

WARNING

Do not rely completely on the LAS.

- The LAS is not an automated driving system. Over reliance on the system could lead to an accident.
- The functions of the LAS have limitations. Do not rely completely on the system and always stay on course using the steering wheel.

Do not use the LAS under the following conditions. Otherwise, it may result in an accident.

- The vehicle is driven on slippery roads such as icy roads, snow-covered roads, and unpaved roads.
- Tyres other than the specified size are used, such as when tyre chains or temporary spare tyres are used.
- Tyres with insufficient tread are used.
- The tyre pressures are not adjusted to the specified pressure.
- The vehicle is towing a camping trailer or boat trailer.
- The vehicle is driven on roads other than expressways or highways with white (yellow) lines.

CAUTION

- Heed the following cautions so that the LAS can operate normally.
 - Do not modify the vehicle's suspensions.

- Always use wheels of the specified size for the front and rear wheels. Consult an expert repairer (we recommend an Authorised Mazda Repairer) for tyre replacement.

How to Use the Lane-keep Assist System (LAS)

When the LAS operates

When all the following conditions are met, the LAS operates to assist the steering wheel operation.

- The vehicle speed is about 60 km/h (37 mph) or faster.
- The system detects white (yellow) lane lines.
- The CTS steering assist function is not operating.
- The system determines that the vehicle may depart from the lane.

While the steering wheel operation assist is operating, the screen display notifies the driver.

Instrument cluster (Type A)

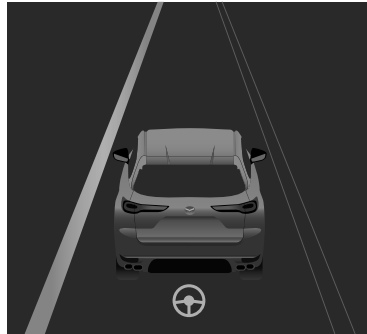

Instrument cluster (Type B)



Active driving display



In addition, even if the steering wheel operation assist is operated, a warning sound is activated when the driver does not operate the steering wheel.

NOTE

- If the system determines that the driver is driving the vehicle with his or her hands off the steering wheel while the steering wheel operation assist is operating and the condition continues several times within a certain period of time, the warning sound is activated. The higher the number of times the steering wheel operation assist operates, the longer the period of time the warning sound is activated.
- The LAS operates only on the side that detects white lines (yellow lines).
- The LAS may not operate normally if any of the following conditions is met.
 - The forward sensing camera (FSC) cannot detect target objects.
Refer to Forward Sensing Camera (FSC) on page 5-133.

- The visibility of white (yellow) lane lines is poor.

LAS temporary cancellation

If any of the following conditions is met, the LAS is temporarily cancelled. The LAS operation is automatically restored when the system's operation conditions are met.

- The direction indicator lever is operated.
- The steering wheel is operated abruptly.
- The accelerator pedal is depressed abruptly.
- The brake pedal is depressed.
- The TCS/DSC is operating.
- **(Except European models)**
The TCS/DSC is turned off.

Turning off the LAS

(European models)

The LAS can be turned off using the Mazda Connect.
Refer to the Settings section in the Mazda Connect Owner's Manual.

(Except European models)

There are 2 ways to turn off the LAS.

- Turn off the LAS using Mazda Connect.
Refer to the Settings section in the Mazda Connect Owner's Manual.
- Turn off the LAS using the i-ACTIVSENSE OFF switch.
Refer to How to Use the i-ACTIVSENSE OFF switch on page 5-132.

Adjustable Speed Limiter (ASL)*

The ASL is a function to prevent the vehicle from being driven at a vehicle speed faster than a set speed. The vehicle speed is controlled to keep it below the set speed even if the accelerator pedal is depressed. If the vehicle speed exceeds the set speed limit while driving under certain conditions such as on a downslope, the system notifies the driver using the display and a warning sound.

Warnings and Cautions for Using the Adjustable Speed Limiter (ASL)

WARNING

Always turn off the system when changing drivers.

If the driver is changed and the new driver is unaware of the ASL function, the vehicle may not accelerate when the driver depresses the accelerator pedal, leading to an accident.

Always verify the safety of the surrounding area when setting the ASL.

If the speed is set lower than the current vehicle speed, the vehicle speed is decreased to the set speed. Verify the safety of the surrounding area and keep a safer distance between vehicles ahead and behind you.

How to Use the Adjustable Speed Limiter (ASL)

Available vehicle speed settings

A vehicle speed can be set from about 30 km/h (19 mph) to 200 km/h (125 mph) with the ASL.

Setting the ASL

1. Press the LIM switch to turn the system on.

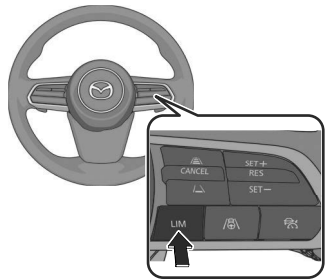

When the system is on, the ASL standby indication (white) LIM is displayed on the screen.

2. Accelerate to the desired speed.
3. Set the vehicle speed by pressing the RES switch up (SET+) or down (SET-).



When you set the speed, the set speed is displayed on the screen. In addition, the ASL standby indication (white) LIM changes to the ASL set indication (green) LIM.

Instrument cluster (Type A) Other than i-ACTIVSENSE display

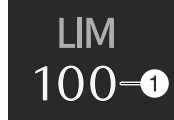

i-ACTIVSENSE display

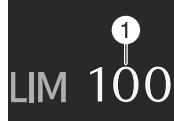

1. Set speed

Instrument cluster (Type B)

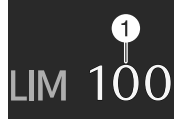

1. Set speed

Active driving display



1. Set speed

NOTE

- The ASL does not operate when the Hill Descent Control is operating.
- The ASL is not cancelled even if the brake pedal is depressed.
- The ASL is temporarily cancelled when the accelerator pedal is completely depressed. Afterwards, when the vehicle speed is slower than the set speed, the ASL operates again.
- The vehicle speed may exceed the set speed depending on the driving conditions such as driving on a steep slope.

Changing the set vehicle speed

Press the RES switch up (SET+) or down (SET-) to the desired speed.

- Press and release immediately: 1 km/h (1 mph)
- Press and hold: 10 km/h (5 mph)

Excessive vehicle speed warning

If the vehicle speed exceeds the set speed by about 5 km/h (3 mph), the background of the set vehicle speed indication flashes. In addition, a warning sound is activated at the same time.

Temporarily cancelling the ASL

If any of the following conditions is met, the ASL is temporarily cancelled.

- The CANCEL switch is pressed one time.
- The accelerator pedal is forcefully depressed.
- Any door is opened.
- The driver's seat belt is unfastened.

If the ASL is temporarily cancelled, it will resume operation at the previously set speed by pressing the RES switch.

Turning off the ASL

Press the LIM switch.

The ASL set indication (green)

LIM /ASL standby indication (white)

LIM turns off, and ASL turns off.

Intelligent Speed Assistance (ISA)*

The ISA is a function which keeps the vehicle speed below the speed limit set from a speed limit sign or an optionally set speed limit.

If the vehicle speed exceeds the set speed limit while driving under certain conditions such as on a downslope, the system notifies the driver using the display and a warning sound.

The ISA recognises a speed limit sign based on the Traffic Sign Recognition System (TSR) or the navigation system information.

Refer to Traffic Sign Recognition System (TSR) on page 5-163

Warnings and Cautions for Using the Intelligent Speed Assistance (ISA)

WARNING

Always turn off the system when changing drivers.

If the driver is changed and the new driver is unaware of the ISA function, the vehicle may not accelerate when the driver depresses the accelerator pedal, leading to an accident.

Always verify the safety of the surrounding area when setting the ISA.

If the speed is set lower than the current vehicle speed, the vehicle speed is decreased to the set speed. Verify the safety of the surrounding area and keep a safer distance between vehicles ahead and behind you.

Always check the traffic signs visually while driving.

Depending on weather and traffic sign conditions, traffic signs may not be recognised or may be displayed differently. Always make it your responsibility as a driver to check the actual traffic signs. Otherwise, it could result in an accident.

How to Use the Intelligent Speed Assistance (ISA)

Available vehicle speed settings

A vehicle speed can be set from about 30 km/h (19 mph) to 200 km/h (125 mph) with the ISA.

Setting the ISA

1. Press the LIM switch to turn the system on.

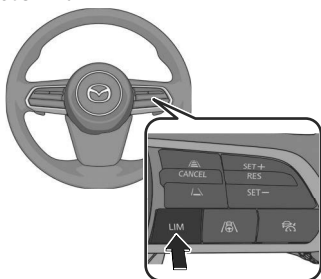

When the system is on, the ISA standby indication (white) LIM is displayed on the screen.

2. Accelerate to the desired speed.
3. Set the vehicle speed by pressing the RES switch up (SET+) or down (SET-).

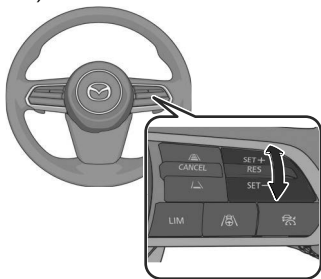

When you set the speed, the set speed is displayed on the screen. In addition, the ISA standby indication (white) LIM changes to the ISA set indication (green) LIM.

Instrument cluster (Type A) Other than i-ACTIVSENSE display

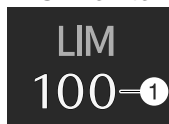

i-ACTIVSENSE display



1. Set speed

Instrument cluster (Type B)

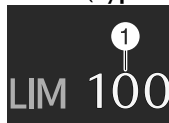

1. Set speed

Active driving display



1. Set speed

NOTE

- The ISA operates even if the SD card of the navigation system is not inserted, but a traffic sign different from the actual traffic sign may be displayed.
- The ISA does not operate when the Hill Descent Control is operating.
- The ISA is not cancelled even if the brake pedal is depressed.
- The ISA is temporarily cancelled when the accelerator pedal is completely depressed. Afterwards, when the vehicle speed is slower than the set speed, the ISA operates again.

- The vehicle speed may exceed the set speed depending on the driving conditions such as driving on a steep slope.
- If the ISA is disabled in Mazda Connect, it switches to the Adjustable Speed Limiter (ASL). Refer to the Settings section in the Mazda Connect Owner's Manual. Refer to Adjustable Speed Limiter (ASL) on page 5-214.

Changing the set vehicle speed

Changing the set vehicle speed using the RES switch

Press the RES switch up (SET+) or down (SET-) to the desired speed.

- Press and release immediately: 1 km/h (1 mph)
- Press and hold: 10 km/h (5 mph)

Reading the set vehicle speed from the speed limit sign using the RES switch

1. Press the RES switch up (SET+) or down (SET-).
2. Press the RES switch when the speed limit sign set indication  turns on.
When the RES switch is pressed, the vehicle speed of the speed limit sign is read to the set vehicle speed.

CAUTION

- The function which recognises speed limit signs has limitations. Always check the set vehicle speed that was read.
- Set the speedometer display unit to the same unit as the speed limit sign. If the units differ, it reads vehicle speeds not intended by the driver.

NOTE

Set vehicle speeds read from speed limit signs can be adjusted. Refer to the Settings section in the Mazda Connect Owner's Manual.

Excessive vehicle speed warning

If the vehicle speed exceeds the set speed by about 5 km/h (3 mph), the background of the set vehicle speed indication flashes. In addition, a warning sound is activated at the same time.

Temporarily cancelling the ISA

If any of the following conditions is met, the ISA is temporarily cancelled.



- The CANCEL switch is pressed one time.
- The accelerator pedal is forcefully depressed.
- Any door is opened.
- The driver's seat belt is unfastened.

If the ISA is temporarily cancelled, it will resume operation at the previously set speed by pressing the RES switch.

Turning off the ISA

Press the LIM switch.

The ISA set indication (green)

 /ISA standby indication (white)
 turns off, and ISA turns off.

Emergency Lane Keeping (ELK)

Emergency Lane Keeping (ELK)*

The ELK is a system designed to assist the driver's steering wheel operation to avoid danger.

The ELK has the following 2 functions.

Road Keep Assist

The Road Keep Assist assists the driver to avoid departure from the road. If your vehicle may be deviating from the road, the Road Keep Assist provides steering assistance to avoid departure from the road. In addition, a screen display and a warning sound notify the driver of the danger.

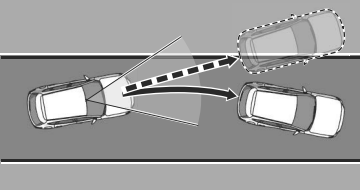

Blind Spot Assist*

The Blind Spot Assist assists the driver in avoiding collisions with vehicles in adjacent lanes (excluding vehicles approaching in the opposite direction).

If there is a possibility of a collision with a vehicle in an adjacent lane when you try to change lanes or if you may deviate from your lane, the Blind Spot Assist assists your steering wheel operation to keep you in the driving lane. In addition, a screen display and

a warning sound notify the driver of the danger.

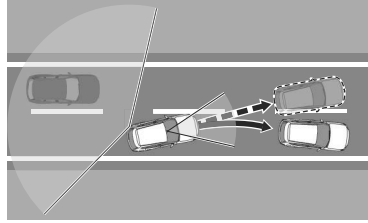

Warnings and Cautions for Using the Emergency Lane Keeping (ELK)

WARNING

Do not rely completely on the ELK.

- The ELK has limitations. Do not rely completely on the system and always stay on course using the steering wheel.
- The ELK is not an automated driving system. Over reliance on the system could lead to an accident.
- The detection range of the camera and sensors is limited. If the steering wheel operation assist is operated without detecting a two-wheeled vehicle near the detecting vehicle, it could result in an accident.

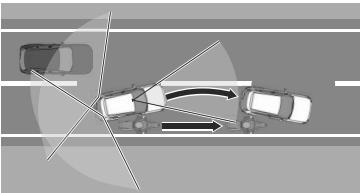

Do not use the ELK under the following conditions. Otherwise, it may result in an accident.

- The vehicle is driven on slippery roads such as icy roads, snow-covered roads, and unpaved roads.
- Tyres other than the specified size are used, such as when tyre chains or temporary spare tyres are used.
- **(Blind Spot Assist)**
 - The vehicle is driven on roads other than expressways and highways.

- The rear bumper around a rear side radar sensor is deformed.

How to Use the Emergency Lane Keeping (ELK)

Road Keep Assist

The Road Keep Assist operates

When all the following conditions are met, the Road Keep Assist operates to assist the steering wheel operation.

- The vehicle speed is about 60 km/h (37 mph) or faster.
- The vehicle is driven on a straight road or gentle curve.
- The function recognises the outside of the road by detecting target objects (such as gravel, grass, street gutters, road curbs, guardrails, or walls).
- The CTS steering assist function is not operating.
- The system determines that your vehicle may deviate from the road.

While the steering wheel operation assist is operating, the screen display notifies the driver.

Instrument cluster (Type A)

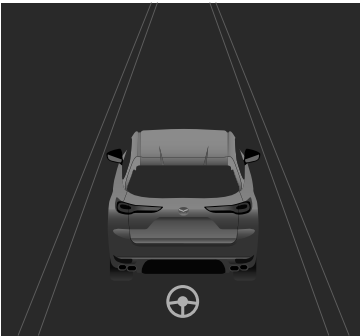

Instrument cluster (Type B)

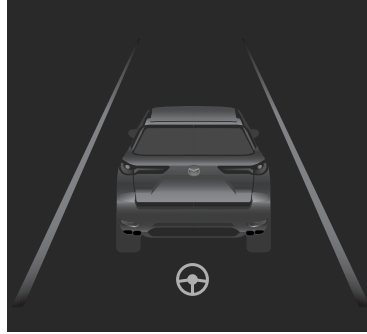

Active driving display

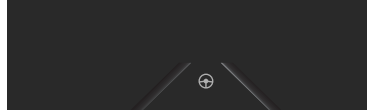

Furthermore, if the possibility of a road departure increases, a screen display and a warning sound notify the driver of the danger. Operate the steering wheel according to the screen display.

Instrument cluster (Type A)

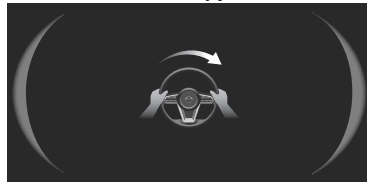

Instrument cluster (Type B)

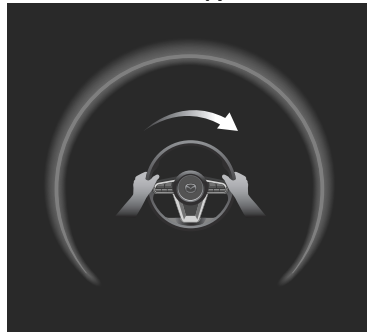

Active driving display



NOTE

- The Road Keep Assist may not operate normally when any of the following conditions is met.
 - The Forward Sensing Camera (FSC) cannot detect target objects. Refer to Forward Sensing Camera (FSC) on page 5-133.
 - The road width is narrow.
- When the system detects target objects on one side only, the system does not operate to avoid a road departure in the direction of the side that is not being detected.
- If the driver operates the steering wheel while the steering wheel operation assist is operating, the steering wheel operation assist is cancelled.
- If the driver is driving the vehicle with his or her hands off the steering wheel while the steering wheel operation assist is operating and the condition continues several times within a certain period of time, the warning sound is activated. The higher the number of times the steering wheel operation assist operates, the longer the period of time the warning sound is activated.

When the Road Keep Assist is temporarily cancelled

The Road Keep Assist goes on stand-by when any of the following conditions is met. The Road Keep Assist is automatically restored when its operation conditions are met.

- The direction indicator lever is operated.
- The accelerator pedal is depressed abruptly.
- The brake pedal is depressed.
- The steering wheel is operated abruptly.
- The TCS/DSC is operating.
- **(Except European models)** The TCS/DSC is turned off.

Blind Spot Assist*

The Blind Spot Assist operates

When all of the following conditions are met, the Blind Spot Assist operates to assist the steering wheel operation.

- The vehicle speed is about 60 km/h (37 mph) or faster.
- The vehicle is driven on a straight road or gentle curve.
- The system detects white (yellow) lane lines on both sides.
- The CTS steering assist function is not operating.
- The system determines that your vehicle may collide with a vehicle from a rear side.

While the steering wheel operation assist is operating, a screen display and a warning sound notify the driver.

Instrument cluster (Type A)



Instrument cluster (Type B)**Active driving display**

Furthermore, if the possibility of a collision increases, a screen display and the warning sound notify the driver of the danger. Operate the steering wheel according to the screen display.

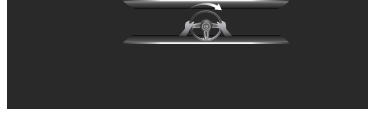
Instrument cluster (Type A)**Instrument cluster (Type B)****Active driving display****NOTE**

- The Blind Spot Assist may not operate normally when any of the following conditions is met.
 - The Forward Sensing Camera (FSC) cannot detect target objects correctly. Refer to Forward Sensing Camera (FSC) on page 5-133.
 - The rear side radar sensors cannot detect target objects correctly. Refer to Radar Sensors on page 5-137.
 - The width of the vehicle lane is narrow or wide.
 - The vehicle is driven on a section with a closed lane or temporary lane due to construction.
 - The vehicle is driven on a forked road or junction.
- If the driver operates the steering wheel while the steering wheel operation assist is operating, the steering wheel operation assist is cancelled.
- If the driver is driving the vehicle with his or her hands off the steering wheel while the steering wheel operation assist is operating and the condition continues several times within a certain period of time, the warning sound is activated. The higher the number of times the steering wheel operation assist operates, the longer the period of time the warning sound is activated.

When the Blind Spot Assist is temporarily cancelled

The Blind Spot Assist goes on stand-by when any of the following conditions is met. The Blind Spot Assist is automatically restored when its operation conditions are met.

- The accelerator pedal is depressed abruptly.
- The brake pedal is depressed.
- The steering wheel is operated abruptly.
- The TCS/DSC is operating.
- **(Except European models)**
The TCS/DSC is turned off.
- Multiple vehicles are travelling in the detecting area near your vehicle.

Turning off the ELK

(European models)

The ELK can be turned off using the Mazda Connect.

Refer to the Settings section in the Mazda Connect Owner's Manual.

(Except European models)

There are 2 ways to turn off the ELK.

- Turn off the ELK using Mazda Connect.
Refer to the Settings section in the Mazda Connect Owner's Manual.
- Turn off the ELK using the i-ACTIVSENSE OFF switch.
Refer to How to Use the i-ACTIVSENSE OFF switch on page 5-132.

When the ELK is turned off, the ELK OFF indicator  turns on.

Smart Brake Support (SBS)*

SBS is a system designed to avoid collisions and reduce damage in the event of a collision by controlling the brakes. Sensors and camera equipped on the vehicle detect objects, and operate brake control if there is a possibility of your vehicle colliding with the object.

One part of the SBS functions when you are driving forward and the other part functions when you are driving in reverse.

Forward drive detection

Forward drive detection has the following 3 functions.

Forward detection function*

The forward detection function is designed to assist the driver in avoiding collisions with objects (vehicles ahead, pedestrians, bicycles, and motorcycles) at the front and to reduce damage in the event of a collision.

If there is a possibility of your vehicle colliding with a target object at the front, you are notified of possible danger by a screen display and a warning sound. Furthermore, if the possibility of a collision increases, brake control is performed to avoid collision and reduce damage in the event of a collision.

In addition, when the driver depresses the brake pedal, the brakes are applied firmly and quickly to assist.

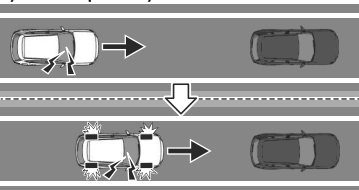

Turn-Across Traffic*

The Turn-Across Traffic is designed to assist the driver in avoiding a collision with a vehicle approaching in the opposite direction when making a right turn (right-hand drive model)/left turn (left-hand drive model) at an intersection and to reduce damage in the event of a collision.

If there is the possibility of your vehicle colliding with a vehicle approaching in the opposite direction when you make a right turn (right-hand drive model)/left turn (left-hand drive model) at an intersection, a screen display and a warning sound notify the driver of the danger. Furthermore, if the possibility of a collision increases, brake control is performed to avoid a collision and to reduce damage in the event of a collision.

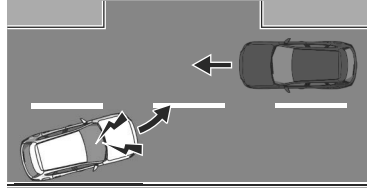

Intersection accident avoidance assist function*

Intersection accident avoidance assist function is designed to avoid collisions with objects (pedestrians and bicycles) when making a left or right turn at an intersection and to reduce damage in the event of a collision.

If there is a possibility of your vehicle colliding with a target object when you make a left or right turn at an intersection, you are notified of possible danger by a screen display and a warning sound. Furthermore, if the possibility of a collision increases, brake control is performed to avoid collision and reduce damage in the event of a collision.

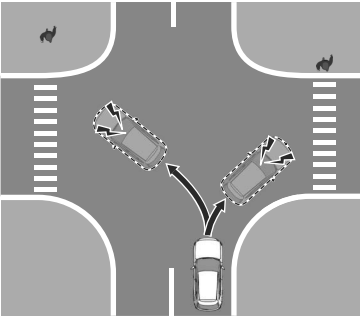

Reverse drive detection

Reverse drive detection has the following 2 functions.

Rearward detection function*

The rearward detection function is designed to assist the driver in avoiding collisions with objects at the rear (obstructions and pedestrians*) and to reduce damage in the event of a collision.

If there is a possibility of your vehicle colliding with a target object at the rear, you are notified of possible danger by a screen display and a warning sound. Furthermore, if the possibility of a collision increases, brake control is performed to avoid collision and reduce damage in the event of a collision.

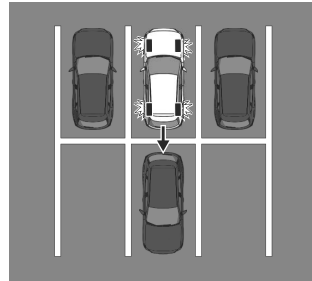

Rear Crossing*

The Rear Crossing is designed to avoid collision and reduce damage in the event of a collision with a vehicle approaching from the rear sides.

If there is a possibility of your vehicle colliding with a vehicle approaching from the rear sides, you are notified of possible danger by a screen display and a warning sound. Furthermore, if the possibility of a collision increases, brake control is performed to avoid collision and reduce damage in the event of a collision.

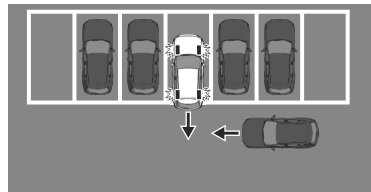

Warnings and Cautions for Using the Smart Brake Support (SBS)

WARNING

Do not rely completely on the SBS.

The SBS is only designed to reduce damage in the event of a collision. Over reliance on the system leading to the accelerator pedal or brake pedal being mistakenly operated could result in an accident.

Heed the following cautions so that the SBS can operate normally.

- Do not modify the suspensions.
- Handle the Forward Sensing Camera (FSC) appropriately. Otherwise, the Forward Sensing Camera (FSC) may not be able to detect target objects, which could result in an accident. Refer to Forward Sensing Camera (FSC) on page 5-133.
- Handle the radar sensors appropriately. Otherwise, the radar sensors may not be able to detect target objects, which could result in an accident. Refer to Radar Sensors on page 5-137.
- Handle the ultrasonic sensors appropriately. Otherwise, the ultrasonic sensors may not be able to detect target objects, which could result in an accident. Refer to Ultrasonic Sensors on page 5-141.
- Handle the rear camera appropriately. Otherwise, the rear camera may not be able to detect target objects, which could result in an accident.

Refer to Cameras on page 5-143.

Always check the surrounding area visually.

The operation of the SBS has certain limitations. Always confirm the safety around the vehicle visually when driving.

CAUTION

- If any of the following conditions is met, turn the SBS off to prevent a mis-operation.
 - A trailer is pulled or an accessory such as a bicycle carrier is installed to the rear of the vehicle.
 - The vehicle is driven on rough roads such as in areas where there is grass and foliage or off-road.
- Always use tyres of the specified size and the same manufacturer, brand, and tread pattern on all 4 wheels. In addition, do not use tyres with significantly different wear patterns on the same vehicle. If such improper tyres are used, the SBS may not operate normally.

How to Use the Smart Brake Support (SBS)

NOTE

During the SBS brake control, the brake pedal may move rearward or become stiff. The brakes are operating, but continue to depress the brake pedal.

When the forward detection function operates*

The forward detection function operates when all of the following conditions are met.

- **(If an object is a vehicle ahead)**
 - The vehicle speed is about 4 km/h (3 mph) or faster.
- **(If an object is a bicycle/pedestrian)**
 - The vehicle speed is about 10 km/h to 80 km/h (6.3 mph to 49 mph).
- The DSC does not operate.
- The system determines that there is a possibility of a collision with an object ahead.

When the forward detection function operates, the driver is notified of the danger by the screen display and warning sound. Furthermore, if the possibility of a collision increases, brake control is performed.

Instrument cluster (Type A)

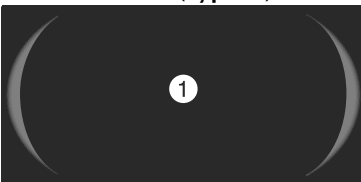

1. "BRAKE!"

Instrument cluster (Type B)



1. "BRAKE!"

Active driving display

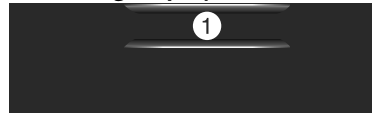

1. "BRAKE!"

NOTE

- If any of the following conditions is met, the forward detection function may not operate normally.
 - The Forward Sensing Camera (FSC) cannot detect target objects. Refer to Forward Sensing Camera (FSC) on page 5-133.
 - The front radar sensor cannot detect target objects. Refer to Radar Sensors on page 5-137.
- When there is the possibility of a partial contact with a target object.
- The driver deliberately performs driving operations (accelerator pedal operation, steering wheel operation, selector lever operation, and direction indicator lever operation).
- If any of the following conditions is met, the forward detection function may operate.

Smart Brake Support (SBS)

- An animal or object on the road is detected.
- Passing an approaching vehicle while rounding a curve.
- Vehicle is passing through a narrow gate or a gate with a low ceiling.
- There is a metal object, bump, or a protruding object on the road.

• (Vehicles with Driver Monitoring (DM))

If the system determines that the driver is not paying attention to the road, it activates the collision warning earlier than normal.

- If the forward detection function performs brake control and the vehicle is stopped, the system will continue to hold the brakes for a brief time unless there is an operation performed by the driver.
- The operation distance and volume of the collision warning can be changed.

Refer to the Settings section in the Mazda Connect Owner's Manual.

The Turn-Across Traffic operation conditions

The Turn-Across Traffic operates when all of the following conditions are met.

- The vehicle speed is about 4 km/h to 20 km/h (3 mph to 12 mph).
- **(Left-hand drive)**
The left direction indicator light is turned on and the vehicle is turning left.
- **(Right-hand drive)**
The right direction indicator light is turned on and the vehicle is turning right.
- A lane line between your vehicle and the vehicle approaching in the opposite direction is detected.
- The system determines that there is a possibility of collision with an object ahead.

When the Turn-Across Traffic operates, the driver is notified of the danger by the screen display and warning sound. Furthermore, if the possibility of a collision increases, brake control is performed.

Instrument cluster (Type A)



1. "BRAKE!"

Instrument cluster (Type B)

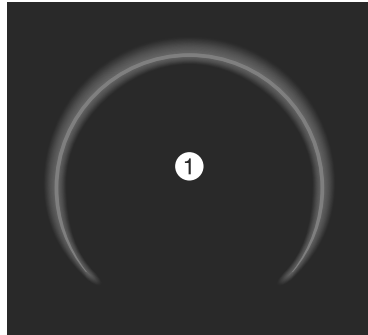

1. "BRAKE!"

Active driving display



1. "BRAKE!"

NOTE

- If any of the following conditions is met, the Turn-Across Traffic may not operate normally.
 - The Forward Sensing Camera (FSC) cannot detect target objects. Refer to Forward Sensing Camera (FSC) on page 5-133.

- The front radar sensor cannot detect target objects. Refer to Radar Sensors on page 5-137.
- The vehicle approaching in the opposite direction is a two-wheeled vehicle or a bicycle.
- All of or only a part of a vehicle approaching in the opposite direction is hidden and it cannot be recognised.
- The speed of the on-coming vehicle is too slow or too fast.
- Turning at a large intersection with two lanes or more on one side.
- The accelerator pedal or brake pedal is being operated.
- The steering wheel is being operated in the straight-ahead position.
- The Turn-Across Traffic may not operate depending on the country where the vehicle is driven.
- If any of the following conditions is met, the Turn-Across Traffic may operate.
 - The steering wheel is turned towards the on-coming traffic lane with a vehicle approaching in the opposite direction.
 - Turning right after or right before an oncoming vehicle passes.
 - The direction of movement of a vehicle approaching in the opposite direction cannot be predicted due to sudden right/left turning or sudden deceleration.
- The brakes are released by the brake control of the Turn-Across Traffic as soon as the danger of a collision passes.

When the intersection accident avoidance assist function operates*

The intersection accident avoidance assist function operates when all of the following conditions are met.

- The vehicle speed is about 8 km/h to 20 km/h (5 mph to 12 mph).
- The DSC is not operating.
- The system determines that there is a possibility of a collision with an object ahead.

If the intersection accident avoidance assist function operates, a screen display and warning sound the driver notify the driver of the danger. Furthermore, if the possibility of a collision increases, brake control is performed.

Instrument cluster (Type A)

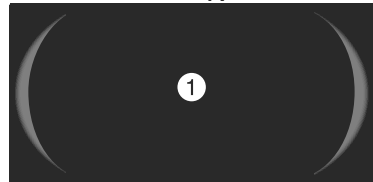

1. "BRAKE!"

Instrument cluster (Type B)

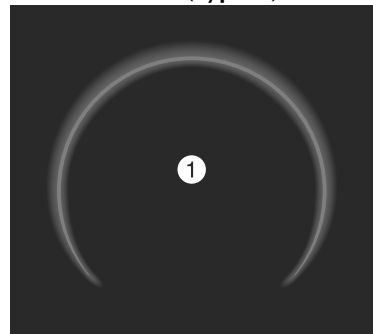

1. "BRAKE!"

Active driving display

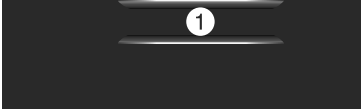

1. "BRAKE!"

NOTE

- If the Forward Sensing Camera (FSC) cannot detect objects, the intersection accident avoidance assist function may not operate normally.
Refer to Forward Sensing Camera (FSC) on page 5-133.
- If the intersection accident avoidance assist function performs brake control and the vehicle is stopped, the system will continue to hold the brakes for a brief time unless there is an operation performed by the driver.

When the rearward detection function operates*

The rearward detection function operates when all of the following conditions are met.

- The vehicle speed is about 2 km/h to 15 km/h (2 mph to 9.3 mph).
- The system determines that there is a possibility of collision with an object at the rear.

When the rearward detection function operates, the screen display and warning sound notify the driver of the danger. Furthermore, if the possibility of a collision increases, brake control is performed.

Instrument cluster (Type A)

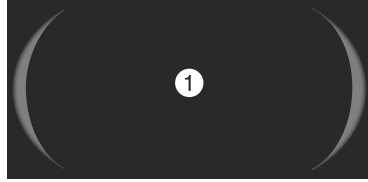

1. "BRAKE!"

Instrument cluster (Type B)



1. "BRAKE!"

Active driving display



1. "BRAKE!"

NOTE

- If any of the following conditions is met, the rearward detection function may not operate normally.
 - The rear ultrasonic sensors cannot detect an object.
Refer to Ultrasonic Sensors on page 5-141.
 - The rear camera cannot detect an object.
Refer to Cameras on page 5-143.
- If any of the following conditions is met, the rearward detection function may operate.

- There is a hanging curtain.
- Vehicle is passing through a narrow gate or a gate with a low ceiling.
- There is a metal object, bump, or a protruding object on the road.
- If the rearward detection function performs brake control and the vehicle is stopped, the system will continue to hold the brakes for a brief time unless there is an operation performed by the driver.

When the Rear Crossing is operating*

The Rear Crossing operates when all of the following conditions are met.

- The vehicle speed is about 15 km/h (9.3 mph) or slower.
- The system determines that there is a possibility of a collision with a vehicle approaching from a rear side.

When the Rear Crossing operates, the screen display and warning sound notify the driver is notified of the danger. Furthermore, if the possibility of a collision increases, brake control is performed.

Instrument cluster (Type A)

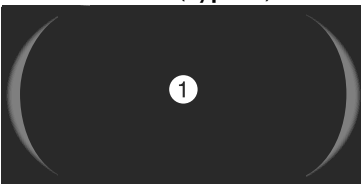

1. "BRAKE!"

Instrument cluster (Type B)



1. "BRAKE!"

Active driving display

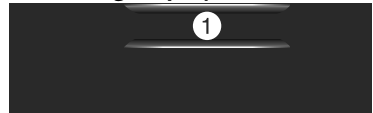

1. "BRAKE!"

NOTE

- If any of the following conditions is met, the Rear Crossing may not operate normally.
 - The rear side radar sensors cannot detect an object.
Refer to Radar Sensors on page 5-137.
 - A vehicle is approaching directly from the rear of your vehicle.
 - A vehicle is approaching at an angle from the rear of your vehicle.
 - A vehicle is approaching from a direction at an acute angle.
- If any of the following conditions is met, the Rear Crossing may operate.
 - There is a hanging curtain.
 - Vehicle is passing through a narrow gate or a gate with a low ceiling.

Smart Brake Support (SBS)

- If the Rear Crossing performs brake control and the vehicle is stopped, the system will continue to hold the brakes for a brief time unless there is an operation performed by the driver.

Turning off the SBS

The SBS can be turned off using the Mazda Connect.

Refer to the Settings section in the Mazda Connect Owner's Manual.

When the SBS is turned off, the SBS

OFF indicator  turns on.

360° View Monitor*

The 360° view monitor is a system which assists the driver in checking safety by displaying the conditions around the vehicle on the centre display when the vehicle is driven at low speeds or when the vehicle is parked or stopped.

Top view

Displays an image of the vehicle as if it were viewed from directly above to assist in checking the area around the vehicle when driving forward or in reverse.

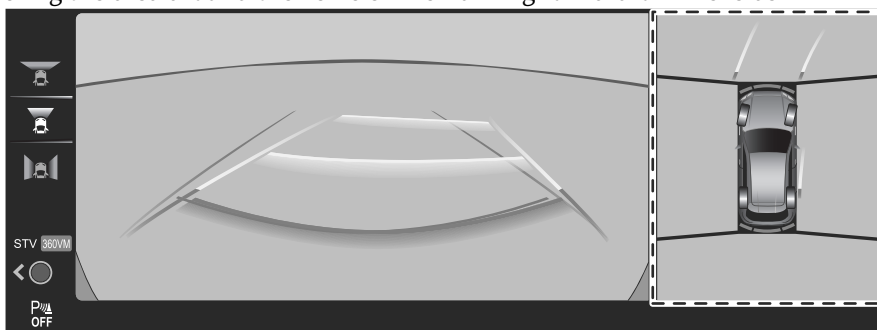

Front view

Displays an image of the front of the vehicle together with the guide lines to assist in checking the area at the front of the vehicle when driving forward, parking, or stopping.

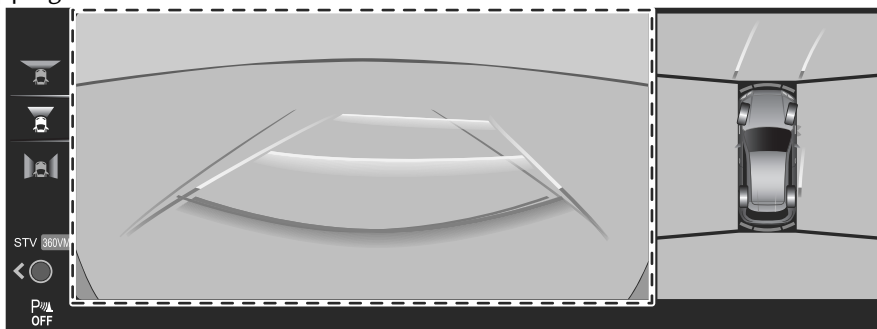

Front wide view

Displays an image of the front of the vehicle (wide area) together with the guide lines to assist in checking the area at the front of the vehicle when driving forward or entering an intersection.

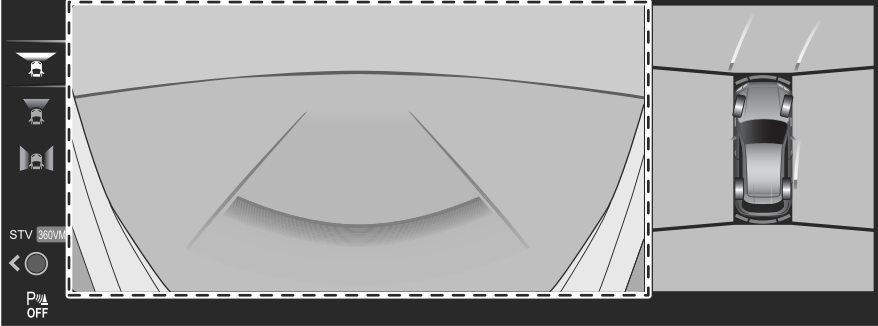

Side view

Displays an image of the front left and right sides of the vehicle together with the guide lines to assist in checking the front left and right sides of the vehicle when driving forward, parking, or stopping.

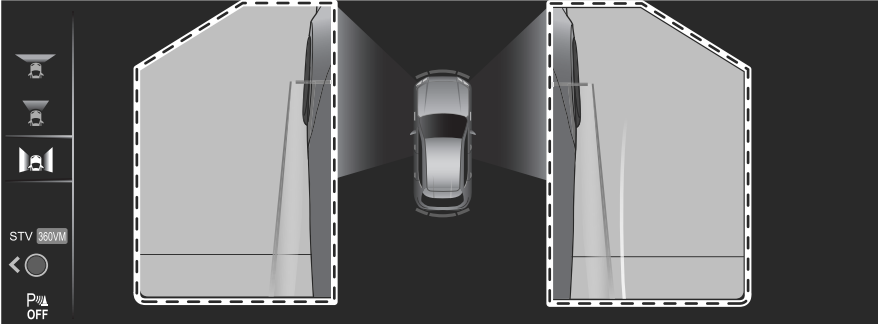

Rear view

Displays an image of the rear of the vehicle together with the guide lines to assist in checking the area at the rear of the vehicle when reversing, parking, or stopping.

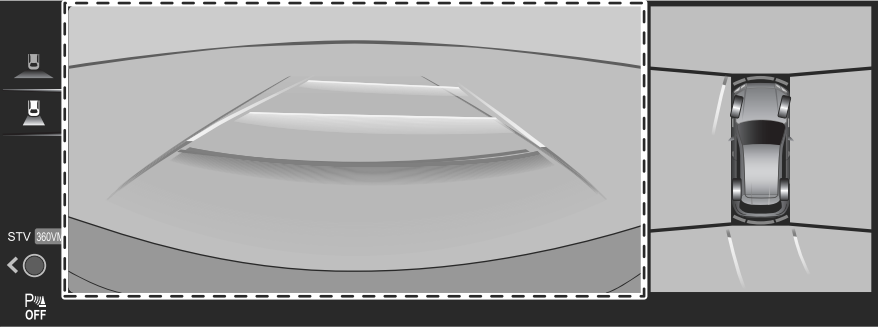

Rear wide view

Displays an image of the rear of the vehicle (wide area) together with the guide lines to assist in checking the area at the rear of the vehicle when reversing, parking, or stopping.

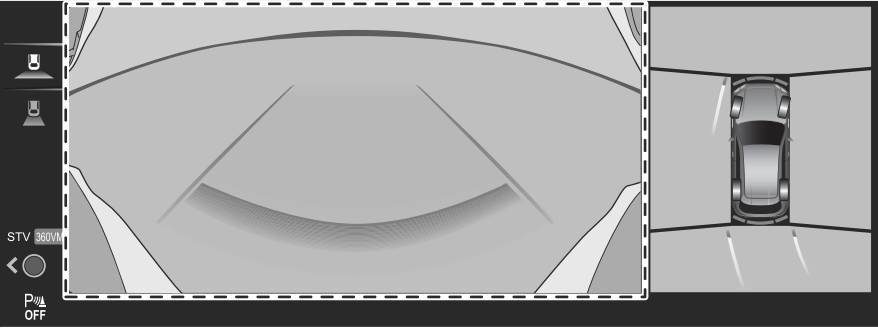

See-Through View*

The See-Through View is a function that combines the images taken by each camera and processes them to look as if the vehicle is transparent and displays them on the centre display.

Front See-Through View

Displays a camera image of the front of the vehicle as though it was transparent together with the guide lines to assist in checking the area at the front/sides of the vehicle when driving forward, parking, or stopping.

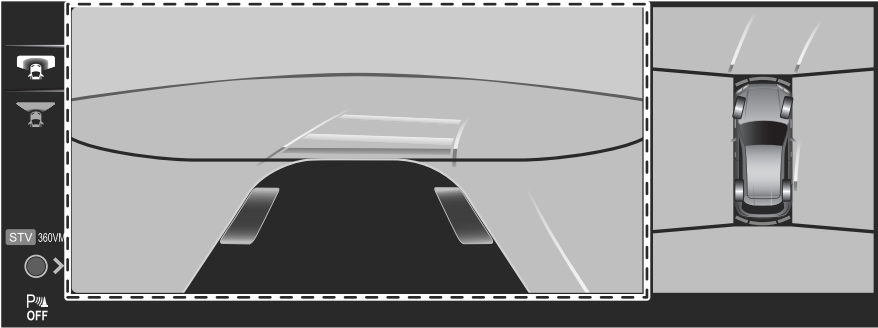

Rear See-Through View

Displays a camera image of the rear of the vehicle as though it was transparent together with the guide lines to assist in checking the area at the rear/sides of the vehicle when reversing, parking, or stopping.

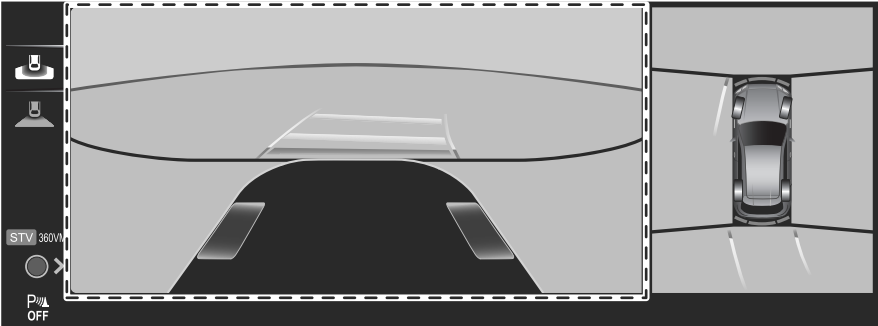

Warnings and Cautions for Using the 360° View Monitor

WARNING

Always confirm the safety of the area around the vehicle visually when driving. The 360° View Monitor is an auxiliary device which assists the driver in checking the safety of the area around the vehicle.

Do not rely completely on the 360° View Monitor.

- The shooting range of the cameras and detection range of the sensors are limited. For example, the following locations displayed on the screen may be blind spots and target objects may not be visible.
 - Areas in black on screen
 - Seams where each of camera images merge
- See-Through View may not be able to accurately display obstructions near the seams of the image.

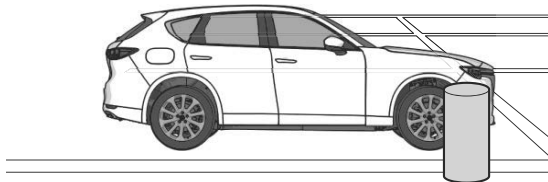
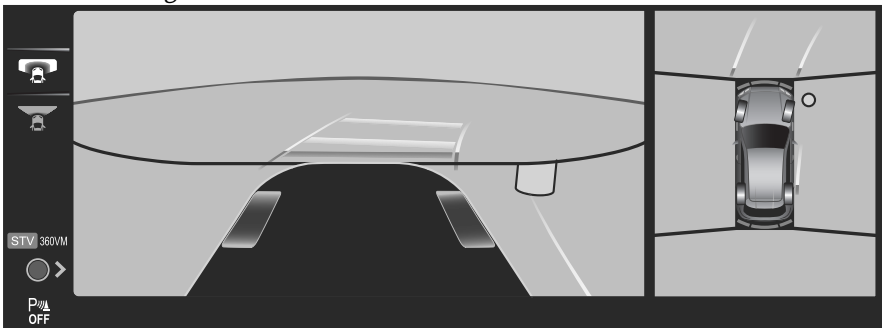

- Vehicle width extension lines and projected vehicle paths are only estimates. Images displayed on the display may differ from the actual conditions.



- Handle the cameras appropriately. If the cameras are handled incorrectly, images may not be displayed normally.
Refer to Cameras on page 5-143.
- Do not use the 360° view monitor in the following locations or conditions.
 - Bumpy roads
 - The vehicle is on a road incline.
 - Icy or snow-covered roads
 - Tyre chains or a temporary spare tyre is installed.
 - The doors are not fully closed.
 - The outside mirrors are retracted.
- If the doors are not completely closed, images and guide lines may not be displayed correctly.
- Heed the following cautions to assure that the 360° view monitor operates normally.
 - Do not modify the suspensions.
 - Always use wheels of the specified size for the front and rear wheels. Consult an expert repairer (we recommend an Authorised Mazda Repairer) for tyre replacement.
- When the centre display is cold, images may leave trails or the display might be darker than usual, making it difficult to check the vehicle surroundings. Always confirm the safety around the vehicle visually when driving.
- Recognizing images at night may be difficult because there are no lights in the shooting range of the side camera. Always confirm the safety around the vehicle visually when driving.
- The method for parking/stopping the vehicle using the 360° View Monitor differs depending on the road conditions and vehicle conditions. In addition, when and how much you turn the steering wheel will differ depending on the situation, therefore always check the vehicle surroundings directly with your eyes while using the system.

How to Use the 360° View Monitor

Displaying images of the vehicle front/sides

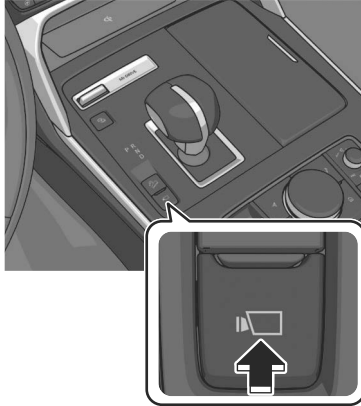

Images are displayed on the centre display.

NOTE

- When the selector lever is in the R position, images of the front/sides of the vehicle are not displayed.
- If any of the following conditions are met, image display of the front/sides of the vehicle ends.
 - Switches around the commander knob are pressed.
 - The vehicle is driven at less than 15 km/h (9.3 mph) for about 4 minutes and 30 seconds.
 - The vehicle speed is 15 km/h (9.3 mph) or faster.
 - The vehicle is driven at 15 km/h (9.3 mph) or faster for 8 seconds.
 - The selector lever is shifted to the P position.

Displaying images of the vehicle rear

Shift the selector lever to the R position.
Images are displayed on the centre display.

Switching the image

1. Turn the commander knob and move the cursor to the desired image.

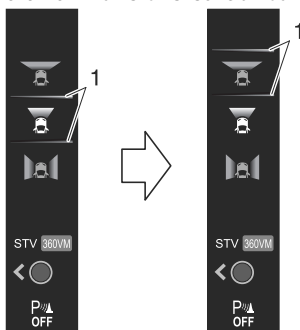

1. Cursor
2. Press the commander knob to select the image to display.

(Vehicles with See-Through View)

Move the commander knob sideways to switch between 360° View mode (360VM) and See-Through View mode (STV).

Viewing the screen

NOTE

- Because there might be a difference between the image displayed on the screen and the actual conditions, always check the safety of the surrounding area directly with your eyes when driving.
- Images may be difficult to see due to the weather and surrounding environment, however this does not indicate a problem.
- The rear view, rear wide view, and rear See-Through View images are reversed left and right
- The actual tyres may appear in the top view and front See-Through View.
- Obstructions displayed in views other than the top view may not be displayed on the top view.
- The areas in black on the top view, front See-Through View, and rear See-Through View and the seams where each of camera images merge are blind spots.
- The top view, front See-Through View, and rear See-Through View are displayed by processing the images taken by each camera. Therefore, images may be displayed as follows.
 - Colour or brightness displayed on the screen may appear differently than in actuality.
 - If the vehicle tilts, the image may appear distorted.
 - Lines on the road may appear distorted at the seams where each of the camera images merge.
- Screen brightness and contrast can be adjusted.
Refer to the Settings section in the Mazda Connect Owner's Manual.

- The parking sensor detection range has limitations. For details, refer to the parking sensor entry.
- Refer to Parking Sensor on page 5-263.
- The screen display may differ from the actual display.

Top view, front view

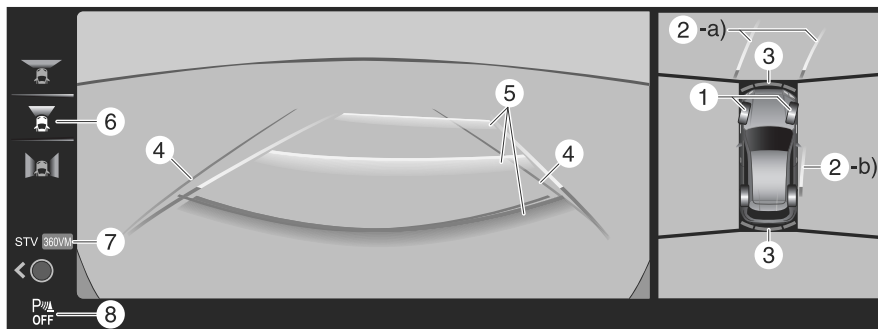

	Indication	Content
1	Tyre icon	Indicates the tyre direction. Moves in conjunction with the steering wheel operation.
2	Projected vehicle path lines (red/yellow)	Indicates the approximate projected path of the vehicle. Moves in conjunction with the steering wheel operation. a) Indicates the path where the edge of the front bumper is expected to travel. b) Indicates the path where the inner side of the vehicle is expected to travel.
3	Parking sensor detection indication	Indicates the obstruction detection status.
4	Vehicle width guide lines (blue)	Indicates the approximate width of the vehicle.
5	Projected vehicle path distance guide lines (red/yellow)	Indicates the distance (from front end of bumper) in front of the vehicle. <ul style="list-style-type: none"> · The red line indicates the point about 50 cm (19 in) from the front end of the bumper. · The yellow lines indicate the points about 1 m (39 in) and 2 m (78 in) from the front end of the bumper.
6	View status icon	Indicates which image is selected.
7	Mode switching icon	Indicates which mode is selected.
8	Parking sensor status icon	Indicates that the parking sensor has a problem or it is switched off.

Top view, front wide view

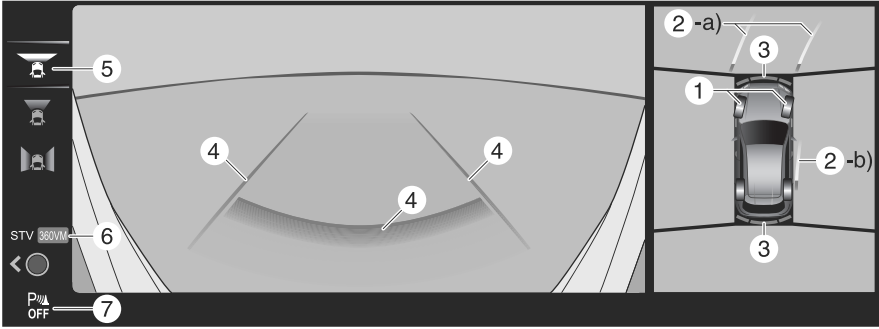

	Indication	Content
1	Tyre icon	Indicates the tyre direction. Moves in conjunction with the steering wheel operation.
2	Projected vehicle path lines (red/yellow)	Indicates the approximate projected path of the vehicle. Moves in conjunction with the steering wheel operation. a) Indicates the path where the edge of the front bumper is expected to travel. b) Indicates the path where the inner side of the vehicle is expected to travel.
3	Parking sensor detection indication	Indicates the obstruction detection status.
4	Extended vehicle width lines and distance guide lines (red/blue)	Indicates the approximate width of the vehicle and the distance (from front end of bumper) in front of the vehicle. <ul style="list-style-type: none"> • The red line indicates the point about 50 cm (19 in) from the front end of the bumper. • The blue lines indicate the points from about 50 cm (19 in) and up to 2 m (78 in) from the front end of the bumper.
5	View status icon	Indicates which image is selected.
6	Mode switching icon	Indicates which mode is selected.
7	Parking sensor status icon	Indicates that the parking sensor has a problem or it is switched off.

NOTE

The front wide view displays the image in front of the vehicle at a wide angle and corrects the image to help detect approaching obstructions from the side. Therefore, it differs from the actual view.

Side view

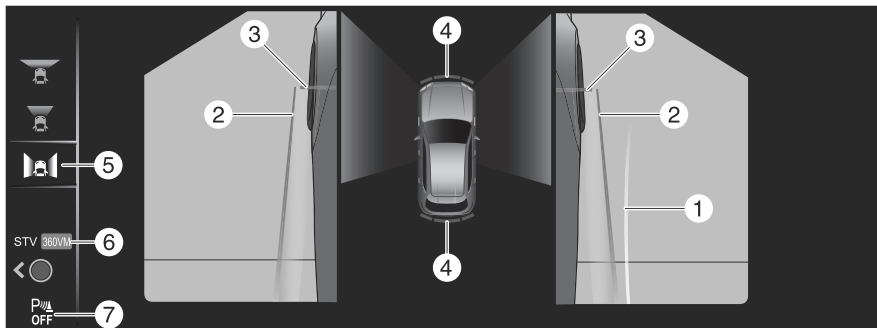

	Indication	Content
1	Projected vehicle path lines (yellow)	Indicates the approximate projected path of the vehicle. Moves in conjunction with the steering wheel operation. The projected vehicle path lines (yellow) indicate the path the inner side of the vehicle is expected to travel.
2	Vehicle parallel guide lines (blue)	Indicates the approximate vehicle width including the outside mirrors.
3	Vehicle front end guide lines (blue)	Indicates the front edge of the vehicle (front edge of the bumper).
4	Parking sensor detection indication	Indicates the obstruction detection status.
5	View status icon	Indicates which image is selected.
6	Mode switching icon	Indicates which mode is selected.
7	Parking sensor status icon	Indicates that the parking sensor has a problem or it is switched off.

⚠ CAUTION

Do not turn the steering wheel any more until the vehicle has passed the obstruction, even if the obstruction is not visible on the side view image. If the steering wheel is turned even more, the vehicle may contact the obstruction if it is turned sharply.

Top view, rear view

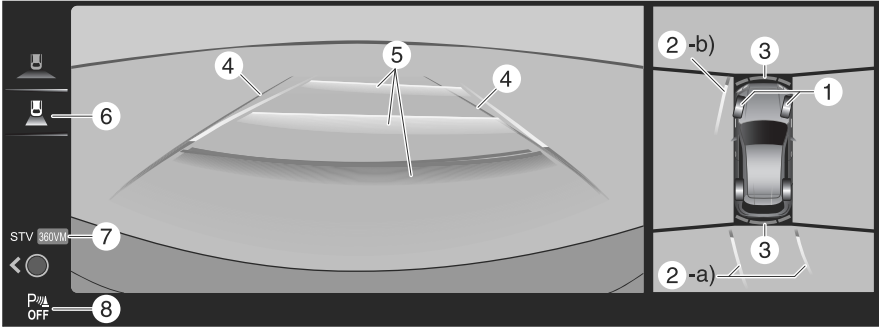

	Indication	Content
1	Tyre icon	Indicates the tyre direction. Moves in conjunction with the steering wheel operation.
2	Projected vehicle path lines (red/yellow)	Indicates the approximate projected path of the vehicle. Moves in conjunction with the steering wheel operation. a) Indicates the path where the rear end of the rear bumper passes as a reference. b) Indicates the path where the outer side of the vehicle is expected to travel.
3	Parking sensor detection indication	Indicates the obstruction detection status.
4	Vehicle width guide lines (blue)	Indicates the approximate width of the vehicle.
5	Projected vehicle path distance guide lines (red/yellow)	These guide lines indicate the approximate distance to a point measured from the rear of the vehicle (from the end of the bumper). <ul style="list-style-type: none"> • The red line indicates the point about 50 cm (19 in) from the rear end of the rear bumper. • The yellow lines indicate the points about 1 m (39 in) and 2 m (78 in) from the rear end of the rear bumper.
6	View status icon	Indicates which image is selected.
7	Mode switching icon	Indicates which mode is selected.
8	Parking sensor status icon	Indicates that the parking sensor has a problem or it is switched off.

CAUTION

The front of the vehicle swings out wide when turning the steering wheel while reversing. Maintain sufficient distance between the vehicle and an obstruction.

NOTE

- Even though the back end of the parking space (or garage) displayed on the screen and distance guide lines appear parallel, they may not actually be parallel.
- When parking in a space with a division line on only one side of the parking space, even though the division line and the vehicle width guide line appear parallel, they may not actually be parallel.

Top view, rear wide view

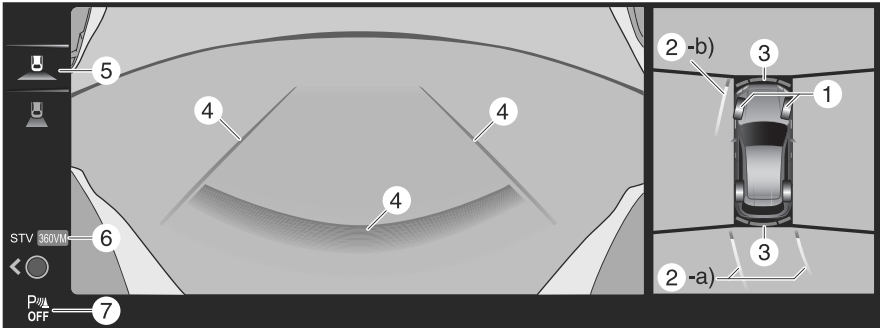

	Indication	Content
1	Tyre icon	Indicates the tyre direction. Moves in conjunction with the steering wheel operation.
2	Projected vehicle path lines (red/yellow)	Indicates the approximate projected path of the vehicle. Moves in conjunction with the steering wheel operation. a) Indicates the path where the rear end of the rear bumper passes as a reference. b) Indicates the path where the outer side of the vehicle is expected to travel.
3	Parking sensor detection indication	Indicates the obstruction detection status.
4	Extended vehicle width lines and distance guide lines (red/blue)	These guide lines indicate the approximate width of the vehicle and distance to a point measured from the rear of the vehicle (from the end of the bumper). • The red line indicates the point about 50 cm (19 in) from the rear end of the rear bumper. • The blue lines indicate the points from about 50 cm (19 in) and up to 2 m (78 in) from the rear end of the bumper.
5	View status icon	Indicates which image is selected.
6	Mode switching icon	Indicates which mode is selected.

	Indication	Content
7	Parking sensor status icon	Indicates that the parking sensor has a problem or it is switched off.

NOTE

The rear wide view displays the image at the rear of the vehicle at a wide angle and corrects the image to help detect approaching obstructions from the side. Therefore, it differs from the actual view.

Top view, front See-Through View

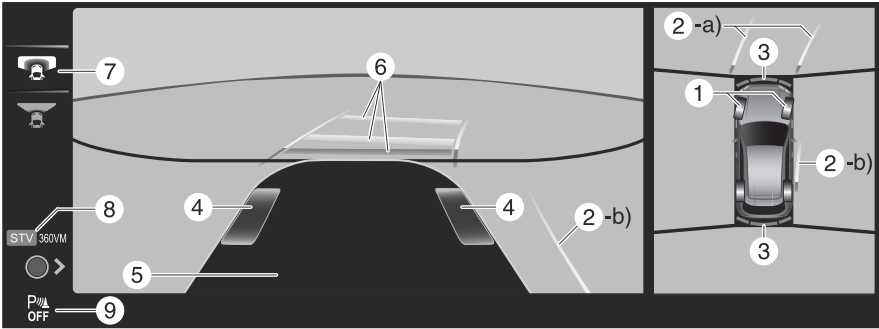

	Indication	Content
1	Tyre icon	Indicates the tyre direction. Moves in conjunction with the steering wheel operation.
2	Projected vehicle path lines (red/yellow)	Indicates the approximate projected path of the vehicle. Moves in conjunction with the steering wheel operation. a) Indicates the path where the edge of the front bumper is expected to travel. b) Indicates the path where the inner side of the vehicle is expected to travel.
3	Parking sensor detection indication	Indicates the obstruction detection status.
4	Tyre graphic	Indicates the approximate position of the tyres.
5	Vehicle bottom graphic	Indicates the estimated bottom of the vehicle.
6	Projected vehicle path distance guide lines (red/yellow)	Indicates the distance (from front end of bumper) in front of the vehicle. • The red line indicates the point about 50 cm (19 in) from the front end of the bumper. • The yellow lines indicate the points about 1 m (39 in) and 2 m (78 in) from the front end of the bumper.
7	View status icon	Indicates which image is selected.

	Indication	Content
8	Mode switching icon	Indicates which mode is selected.
9	Parking sensor status icon	Indicates that the parking sensor has a problem or it is switched off.

NOTE

The front See-Through View may be displayed as follows.

- The ground and three-dimensional objects may appear curved.
- The representation of three-dimensional objects changes at the joints of images and the same object may appear to be duplicated or not connected.

Top view, rear See-Through View

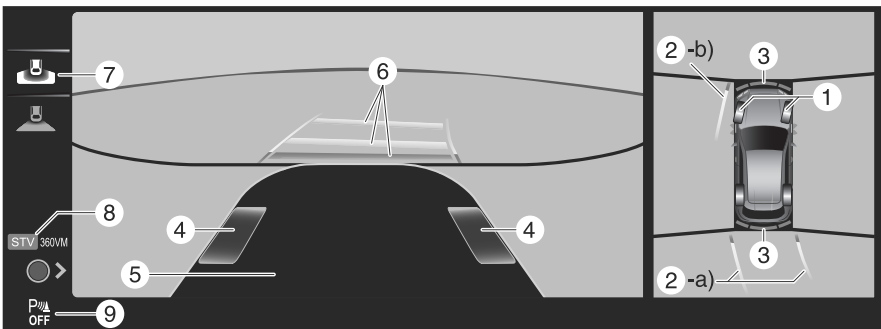

	Indication	Content
1	Tyre icon	Indicates the tyre direction. Moves in conjunction with the steering wheel operation.
2	Projected vehicle path lines (red/ yellow)	Indicates the approximate projected path of the vehicle. Moves in conjunction with the steering wheel operation. a) Indicates the path where the rear end of the rear bumper passes as a reference. b) Indicates the path where the outer side of the vehicle is expected to travel.
3	Parking sensor detection indication	Indicates the obstruction detection status.
4	Tyre graphic	Indicates the approximate position of the tyres.
5	Vehicle bottom graphic	Indicates the estimated bottom of the vehicle.

	Indication	Content
6	Projected vehicle path distance guide lines (red/yellow)	<p>These guide lines indicate the approximate distance to a point measured from the rear of the vehicle (from the end of the bumper).</p> <ul style="list-style-type: none">• The red line indicates the point about 50 cm (19 in) from the rear end of the rear bumper.• The yellow lines indicate the points about 1 m (39 in) and 2 m (78 in) from the rear end of the rear bumper.
7	View status icon	Indicates which image is selected.
8	Mode switching icon	Indicates which mode is selected.
9	Parking sensor status icon	Indicates that the parking sensor has a problem or it is switched off.

NOTE

The rear See-Through View may be displayed as follows.

- The ground and three-dimensional objects may appear curved.
- Expressions such as three-dimensional objects change at the seams of the image, and the same objects may be displayed in duplicate or may be connected and not visible.

System problem indication

In the following cases, there might be a problem with the system. Have the vehicle inspected by an expert repairer (we recommend an Authorised Mazda Repairer).

- "No camera signal." is displayed on the centre display.
- The display on the centre display does not switch to the camera image even if the selector lever is shifted to the R position.
- The display on the centre display does not switch to the camera image even if the 360° view monitor switch is pressed.
- A portion of the display on the centre display is black.

Convenient Ways to Use the 360° View Monitor

The 360° View Monitor settings can be changed as follows.

Refer to the Settings section in the Mazda Connect Owner's Manual.

- Automatic display of the 360° View Monitor when the vehicle power is switched ON.
- When the 360° view mode/ See-Through View mode is activated, the preferentially displayed images can be selected.
- Automatic display of the front view or front See-Through View when switching from reverse to forward gear.
- No display of the projected vehicle path lines.

Secondary Collision Reduction *

The Secondary Collision Reduction reduces secondary damage by decelerating the vehicle when it is damaged in a collision to the extent that the airbags are deployed while driving.

If a collision occurs to the extent that the airbags are deployed while driving, the hazard warning lights flash to alert surrounding vehicles and the brakes are controlled to reduce damage in the event of a collision with an obstruction or other object.

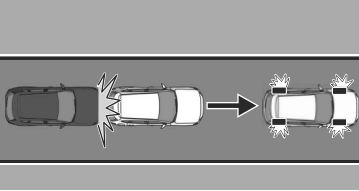

Warnings and Cautions for Using the Secondary Collision Reduction

WARNING

Do not rely completely on the Secondary Collision Reduction.

- The Secondary Collision Reduction may not operate normally depending on various conditions such as the accident condition, component part damage condition, target object condition, weather conditions, or traffic conditions. Do not rely completely on the system and make it your responsibility as a driver to drive the vehicle.
- The functions of the Secondary Collision Reduction have limitations. If you neglect to operate the brake and accelerator pedals correctly, it could result in serious injury.

Secondary Collision Reduction

How to Use the Secondary Collision Reduction

When the Secondary Collision Reduction operates

The Secondary Collision Reduction operates if the vehicle is damaged in a collision to the extent that the airbags are deployed while driving.

When the Secondary Collision Reduction operates, the system controls and applies the brakes until the vehicle stops. In addition, the hazard warning lights continue to flash. After the vehicle stops, the parking brake is applied by the Electric Parking Brake (EPB).

NOTE

- The brake lights turn on while the brakes are operating by the system control.
- If there is a malfunction with the electric parking brake (EPB), the brakes are released by the system control after the vehicle is stopped.
- The settings for the Secondary Collision Reduction system differ depending on the grade/specification-separate equipment.

Secondary Collision Reduction is disabled

If any of the following conditions is met, the Secondary Collision Reduction is cancelled.

- A certain period of time has passed since the system operated.
- After stopping the vehicle, the accelerator pedal is strongly depressed 3 times.

- The parking brake is released after the Electric Parking Brake (EPB) operates.

NOTE

- If the driver's brake pedal depression force is stronger than the system's brake control, the driver's brake operation takes priority.
- Flashing of the hazard warning lights by the system control is cancelled when any of the following operations is performed.
 - Hazard warning light switch is pressed.
 - Vehicle power is switched OFF.

Cruise Control*

Cruise control reduces the load on the driver by driving the vehicle at a constant speed. The vehicle is driven at the preset speed and maintaining a constant vehicle speed without the driver having to depress the accelerator or brake pedal.

Warnings and Cautions for Using the Cruise Control

WARNING

Do not rely completely on the cruise control.

The functions of the cruise control have limitations. Always drive carefully by checking the safety of your surroundings and depressing the brake or accelerator pedal.

Do not use the cruise control under the following conditions. Otherwise, it may result in an accident.

- The vehicle is driven on roads other than highways.
- The vehicle is driven on roads with sharp curves or with heavy traffic where sufficient distances between vehicles cannot be kept.
- The vehicle is driven on slippery roads such as icy or snow-covered roads, and unpaved roads.
- The vehicle is driven on a long downslope.
- The vehicle is driven on a steep slope.

Turn off the cruise control when not in use.

Leaving the cruise control turned on when it is not in use is dangerous as it could operate unexpectedly, resulting in an accident.

CAUTION

- Turn off the cruise control when being towed or when towing another vehicle.

- Turn off the cruise control when the vehicle is running on a chassis roller.

How to Use the Cruise Control

Setting the cruise control

1. Press the cruise control switch to turn the system on.

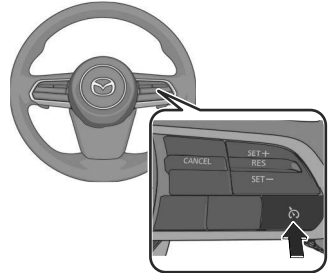



When the system is on, the cruise control standby indication (white)

 is displayed.

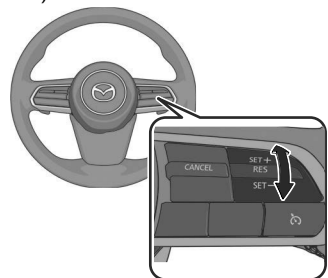
2. Accelerate the vehicle to the desired speed of 25 km/h (16 mph) or faster (minimum speed setting is 30 km/h (19 mph)).
3. Set the vehicle speed by pressing the RES switch up (SET+) or down (SET-).



When the vehicle speed is set, the set vehicle speed is displayed on the displays and the cruise control standby indication (white) 

changes to the cruise control set indication (green) .

While the cruise control is operating, the driver is notified of the operation condition by the screen display.

Instrument cluster (Type A)

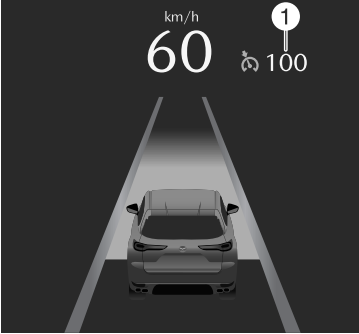

1. Set speed

**Instrument cluster (Type B)
i-ACTIVSENSE display**

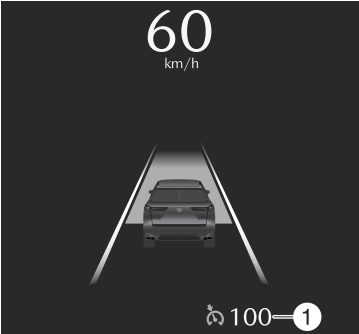

1. Set speed

**Instrument cluster (Type B) Other than
i-ACTIVSENSE display**

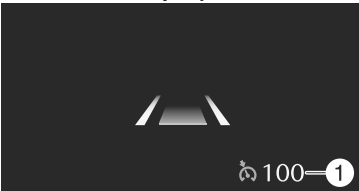

1. Set speed

Active driving display

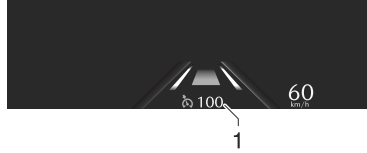

1. Set speed

NOTE

- The cruise control does not operate when the Hill Descent Control is operating.
- The accelerator pedal operation takes priority during constant speed driving. When you release your foot from the accelerator pedal, the vehicle returns to constant speed driving at the set speed.
- **(Vehicles with Mazda Radar Cruise Control with Stop & Go function (MRCC with Stop & Go function))**
If the distance between vehicles control is disabled using the Mazda Connect, the system switches to the cruise control. At this time, the MRCC switch functions as the cruise control switch.
Refer to the Settings section in the Mazda Connect Owner's Manual.
If the vehicle power is switched OFF while the distance between vehicles control is disabled, the distance between vehicles control is enabled automatically the next time the vehicle power is switched ON.
- The system may not be able to maintain the set speed depending on the road conditions such as steep up or down slopes.
- When the vehicle speed is less than 20 km/h (12 mph), the cruise control is cancelled. If you want to use the cruise control again, reset the cruise control.

- The brake lights turn on while the brakes are operating by the cruise control.
- The cruise control cannot be cancelled while driving in manual shift mode (selector lever shifted from the D to M position). Therefore, engine braking does not work even if you shift down to a lower gear. If deceleration is required, lower the set vehicle speed or depress the brake pedal.

Changing the set vehicle speed

Changing the set vehicle speed using the RES switch

Press the RES switch up (SET+) or down (SET-) to the desired speed.

- Press and release immediately: 1 km/h (1 mph)
- Press and hold: 10 km/h (5 mph)

Changing the set vehicle speed using the accelerator pedal

Depress the accelerator pedal until the vehicle speed reaches the desired speed, then press the RES switch up (SET+) or down (SET-).

The cruise control is temporarily cancelled

The cruise control is temporarily cancelled when one of the following conditions is met.

- The brake pedal is depressed.
- The CANCEL switch is pressed one time.
- The DSC has operated.
- The Smart Brake Support (SBS) has operated.
- The frequency of the braking operation by the cruise control is high.

If the cruise control is temporarily cancelled, it operates at the previously set speed by pressing the RES switch.

Turning off the cruise control

Press the cruise control switch.

The cruise control standby indication

(white)  /cruise control set

indication (green)  turns off and the cruise control stops.

Rear View Monitor*

The rear view monitor is a system which assists the driver in checking safety by displaying the conditions behind the vehicle on the centre display when the vehicle is driven in reverse.

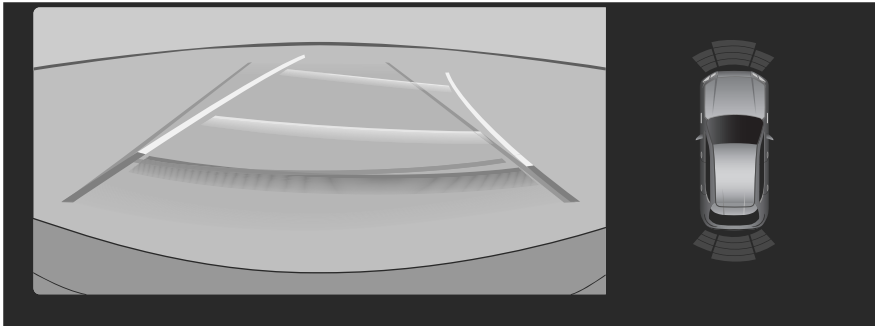

Warnings and Cautions for Using the Rear View Monitor

WARNING

Always confirm the safety of the area around the vehicle visually when driving. The rear view monitor is only designed to assist the driver while reversing. Images displayed on the display may differ from the actual conditions. Do not rely completely on the rear view monitor while reversing. Otherwise, the vehicle may contact an obstruction and cause an accident.

CAUTION

- Do not use the rear view monitor in the following locations/situations.
 - There is a bump on a road.
 - The vehicle is on a road incline.
 - Icy or snow-covered slippery roads.
 - Tyre chains or a temporary spare tyre is installed.
 - The liftgate is not fully closed.
- When the centre display is cold, images may leave trails or the display might be darker than usual, making it difficult to check the vehicle surroundings. Always confirm the safety around the vehicle visually when driving.

How to Use the Rear View Monitor

Displaying the rear view monitor

Shift the selector lever to the R position.
Images are displayed on the centre display.

Viewing the screen

NOTE

- The images displayed on the centre display are reversed left and right.
- Screen brightness and contrast can be adjusted.
Refer to the Settings section in the Mazda Connect Owner's Manual.

Type A

When the parking sensor is ON

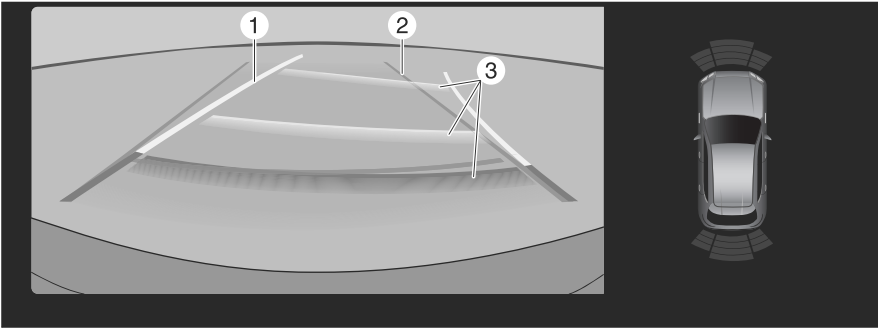

When the parking sensor is OFF

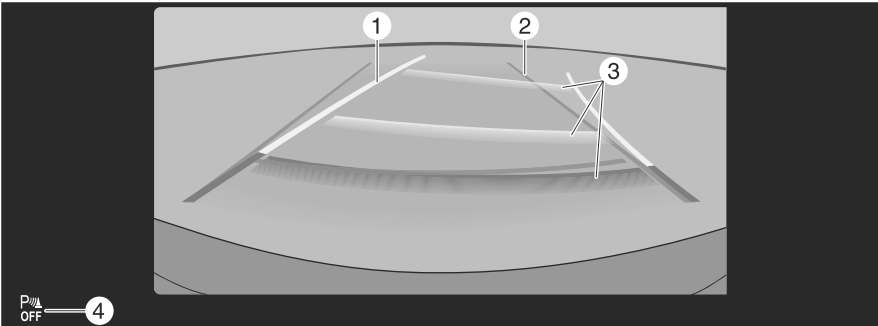

	Indication	Content
1	Projected vehicle path lines (yellow)	Indicates the approximate projected path of the vehicle. The projected vehicle path lines move in conjunction with the steering wheel operation.

	Indication	Content
2	Vehicle width guide lines (blue)	Indicates the approximate width of the vehicle. Does not display when the steering wheel is operated in a straight-ahead position.
3	Projected vehicle path distance guide lines (red/yellow)	These guide lines indicate the approximate distance to a point measured from the rear of the vehicle (from the end of the bumper). <ul style="list-style-type: none"> • The centre point of the red line indicates the point about 50 cm (19 in) from the rear end of the rear bumper. • The centre points of the yellow lines indicate the points about 1 m (39 in) and 2 m (78 in) from the rear end of the rear bumper.
4	Parking sensor status icon	Indicates that the parking sensor has a problem or it is switched off.

Type B

When the parking sensor is ON

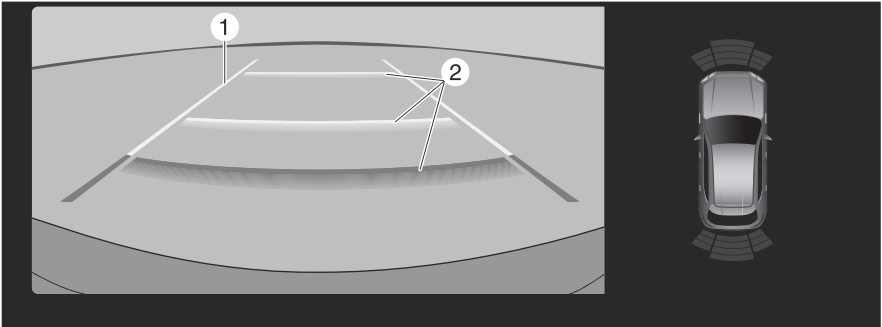

When the parking sensor is OFF

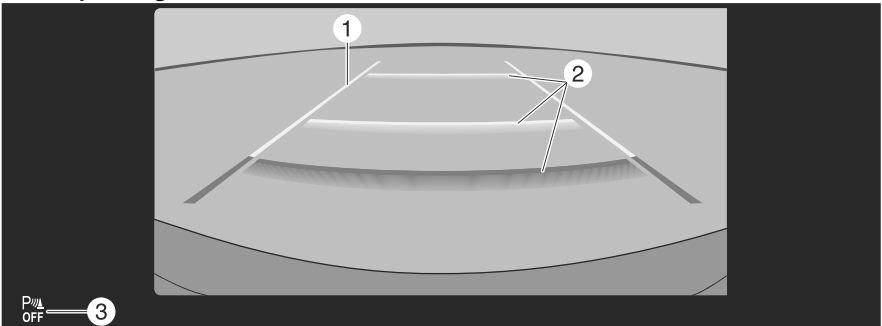

	Indication	Content
1	Vehicle width guide lines (yellow)	Indicates the approximate width of the vehicle.
2	Projected vehicle path distance guide lines (red/yellow)	<p>These guide lines indicate the approximate distance to a point measured from the rear of the vehicle (from the end of the bumper).</p> <ul style="list-style-type: none"> • The red line indicates the point about 50 cm (19 in) from the rear end of the rear bumper. • The yellow lines indicate the points about 1 m (39 in) and 2 m (78 in) from the rear end of the rear bumper.
3	Parking sensor status icon	Indicates that the parking sensor has a problem or it is switched off.

System problem indication

In the following cases, there might be a problem with the system. Have the vehicle inspected by an expert repairer (we recommend an Authorised Mazda Repairer).

- "No camera signal." is displayed on the centre display.
- The display on the centre display does not switch to the camera image even if the selector lever is shifted to the R position.
- A portion of the display on the centre display is black.

Parking Sensor*

The parking sensors are a system that assists the driver in checking safety by detecting obstructions around the vehicle and notifying the driver while parking. When an obstruction is detected, a screen display and a warning sound notify the driver of the distance to the obstruction.

Warnings and Cautions for Using the Parking Sensor

WARNING

Always confirm the safety of the area around the vehicle visually when driving.





The parking sensors are only auxiliary devices when driving forward or in reverse. In addition, the detection range of the sensors is limited, and driving the vehicle relying on the system completely may cause an accident.





How to Use the Parking Sensor

The parking sensors operate



When the system detects an obstruction, the driver is notified of the presence of the obstruction by a screen display and a warning sound. The screen display and warning sound change according to the distance from the obstruction. In addition, if multiple obstructions are detected simultaneously, the warning sound for the nearest obstruction is activated.

Front*, rear





Distance between vehicle and obstruction		Display		Warning sounds
Front	Rear	Vehicles without 360° View Monitor	Vehicles with 360° View Monitor	
About 1 m to 60 cm (39 in to 24 in)	About 1 m 50 cm to 60 cm (59 in to 24 in)	Green 	Green 	Slow, intermittent sound
About 60 cm to 50 cm (24 in to 20 in)	About 60 cm to 50 cm (24 in to 20 in)	Yellow 	Yellow 	Intermittent sound

Distance between vehicle and obstruction		Display		Warning sounds
Front	Rear	Vehicles without 360° View Monitor	Vehicles with 360° View Monitor	
About 50 cm to 40 cm (20 in to 16 in)	About 50 cm to 40 cm (20 in to 16 in)	Amber 	Amber 	Fast intermittent sound
Within about 40 cm (16 in)	Within about 40 cm (16 in)	Red 	Red 	Continuous sound

Corners

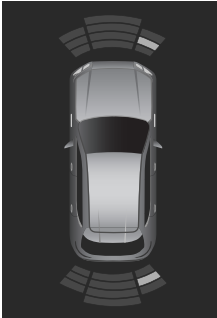
Distance between vehicle and obstruction	Display		Warning sounds
	Vehicles without 360° View Monitor	Vehicles with 360° View Monitor	
About 50 cm to 40 cm (20 in to 16 in)	Yellow 	Yellow 	Intermittent sound

Driving
Parking Sensor

Distance between vehicle and obstruction	Display		Warning sounds
	Vehicles without 360° View Monitor	Vehicles with 360° View Monitor	
About 40 cm to 30 cm (16 in to 12 in)	Amber 	Amber 	Fast intermittent sound
Within about 30 cm (12 in)	Red 	Red 	Continuous sound

NOTE

- If ultrasound sensors cannot detect an object correctly, the system may not operate normally.
Refer to Ultrasonic Sensors on page 5-141.
- The screen display can be switched between display and non-display and the volume of the warning sound can be changed.
Refer to the Settings section in the Mazda Connect Owner's Manual.
- **(Vehicles with 360° View Monitor)**
When the screen display is set to be displayed, the display automatically switches to the 360° View Monitor display when the sensor detects an obstruction. When an obstruction is no longer detected, the display switches to the display before the obstruction was detected. However, when the 360° View Monitor is displayed in advance, it continues to be displayed no matter if an obstruction is detected or not.

- If an obstruction in the same detection range is detected continuously for 6 seconds or longer, only the warning sound stops (excluding the closest detection range). When the detection range changes to the close side, the warning sound resumes.

Turning off the parking sensors

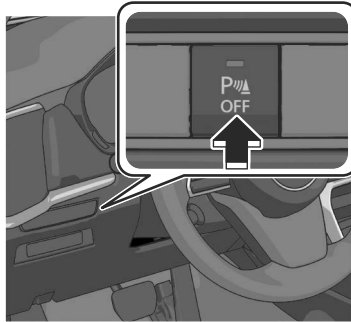

The parking sensors turn off and the parking sensor OFF switch indicator light turns on.

If the switch is pressed again, the parking sensors become operational and the indicator light of the switch turns off.

System problem indication

- If a problem occurs, the following display notifies the driver. The system may have a malfunction. Have the vehicle inspected by an expert repairer (we recommend an Authorised Mazda Repairer).
(Vehicles without 360° View Monitor)



(Vehicles with 360° View Monitor)



- If a certain obstruction detection indication is continuously displayed, make sure that there is no foreign matter on the sensor area corresponding to the detection indicator. If the system does not recover, have the vehicle inspected by an expert repairer (we recommend an Authorised Mazda Repairer).

Winter Driving

Carry emergency gear, including tyre chains, window scraper, flares, a small shovel, jumper leads, and a small bag of sand or salt.

Ask an expert repairer (we recommend an Authorised Mazda Repairer) to check the following:

- Have the proper ratio of antifreeze in the radiator.
Refer to Inspecting the Coolant on page 9-37.
- Inspect the lead-acid battery and its leads. Cold reduces battery capacity.
- Use an engine oil appropriate for the lowest ambient temperatures that the vehicle will be driven in (page 9-41).
- Inspect the ignition system for damage and loose connections.
- Use washer fluid made with antifreeze—but do not use engine coolant antifreeze for washer fluid (page 9-40).

When driving on ice or in water, snow, mud, sand, or similar hazards:

- Be cautious and allow extra distance for braking.
- Avoid sudden braking and sudden manoeuvring.
- Do not pump the brakes. Continue to press down on the brake pedal. Refer to Antilock Brake System (ABS) on page 5-95.
- If you get stuck, select a lower gear and accelerate slowly. Do not spin the rear wheels.
- For more traction in starting on slippery surfaces such as ice or packed snow, use sand, rock salt, chains, carpeting, or other nonslip material under the rear wheels.

NOTE

- Remove snow before driving. Snow left on the windscreen is dangerous as it could obstruct vision.
- Do not apply excessive force to a window scraper when removing ice or frozen snow on the mirror glass and windscreen.
- Never use warm or hot water for removing snow or ice from windows and mirrors as it could result in the glass cracking.
- Drive slowly. Braking performance can be adversely affected if snow or ice adheres to the brake components. If this situation occurs, drive the vehicle slowly, releasing the accelerator pedal and lightly applying the brakes several times until the brake performance returns to normal.

Snow Tyres

WARNING

Use only the same size and type tyres (snow, radial, or non-radial) on all 4 wheels:

Using tyres different in size or type is dangerous. Your vehicle's handling could be greatly affected and result in an accident.

CAUTION

Check local regulations before using studded tyres.

Use snow tyres on all 4 wheels

Do not exceed the maximum permissible speed for your snow tyres or legal speed limits.

Europe

When snow tyres are used, select the specified size and pressure (page 10-91).

Tyre Chains

Check local regulations before using tyre chains.

CAUTION

- Chains may affect handling.
- Do not go faster than 50 km/h (30 mph) or the chain manufacturer's recommended limit, whichever is lower.
- Drive carefully and avoid bumps, holes, and sharp turns.
- Avoid locked-wheel braking.
- Do not use chains on a temporary spare tyre; it may result in damage to the vehicle and to the tyre.
In some models, the vehicle is not equipped with a factory installed temporary spare tyre.
- Do not use chains on roads that are free of snow or ice. The tyres and chains could be damaged.
- Chains may scratch or chip aluminium wheels.

NOTE

If your vehicle is equipped with the tyre pressure monitoring system, the system may not function correctly when using tyre chains.

Install the chains on the rear tyres only. Do not use chains on the front tyres.

Tyre chain selection (Europe)

Mazda recommends hexagon type steel ring chains. Select the proper type according to your tyre size.

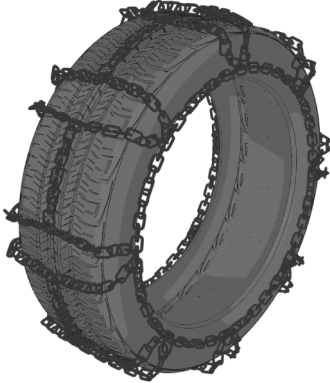

NOTE

Although Mazda recommends hexagon type steel ring chains, all chains within the installation specifications may be used.

Installation specification (Europe)

When installing tyre chains, the distance between the tyre tread and the chain must be within the prescribed limits in the following table.

Distance [Unit mm (in)]

Side view

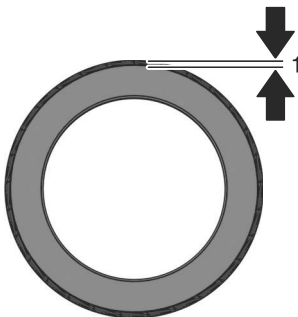

1. MAX 13 (0.51)

Cross section view



1. MAX 13(0.51)

Installing the chains

1. Secure the chains on the rear tyres as tightly as possible. Always follow the chain manufacturer's instructions.
2. Retighten the chains after driving 1/2—1 km (1/4—1/2 mile).

Turbocharger (e-SKYACTIV G, e-SKYACTIV D)

The turbocharger greatly enhances engine power. Its advanced design provides improved operation and requires minimum maintenance.

Warnings and Cautions for Using the Turbocharger

CAUTION

- After driving at freeway speeds or up a long hill, trailer towing for a long time, idle the engine at least 30 seconds before stopping it. Otherwise, the turbocharger could be damaged. However, when i-stop operates, idling is unnecessary.
- Racing or over-revving the engine, particularly after it's just been started, can damage the turbocharger.
- To protect the engine from damage, the engine is designed so that it cannot be raced just after starting it in extremely cold weather.

How to Use the Turbocharger

To get the most from it, observe the following.

1. Change engine oil and filter according to Scheduled Maintenance. Refer to Maintenance Table on page 9-6.
2. Use only recommended engine oil (page 9-33). Extra additives are NOT recommended.

MEMO

6

Equipment to Make Cabin More Comfortable

Fully Automatic Air-Conditioning	6-2
Air Vents.....	6-2
How to Use the Air Vents.....	6-2
Fully Automatic Air-Conditioning.....	6-4
Fully Automatic Air-Conditioning Overview.....	6-6
How to Use the Fully Automatic Air-Conditioning.....	6-7
Operating Each Switch.....	6-7
Seat Warmer	6-12
Seat Warmer*	6-12
Warnings and Cautions For Using the Seat Warmer.....	6-12
How to Use the Seat Warmer.....	6-13
Convenient Ways to Use the Seat Warmer.....	6-14
Heated Steering Wheel	6-15
Heated Steering Wheel*	6-15
Warnings and cautions For Using the Heated Steering Wheel	6-15

How to Use Heated Steering Wheel.....	6-16
Convenient Ways to Use Heated Steering Wheel.....	6-16

Seat Ventilation	6-17
Seat Ventilation*	6-17
Warnings and cautions For Using the Seat Ventilation.....	6-17
How to Use the Seat Ventilation.....	6-18
Convenient Ways to Use the Seat Ventilation.....	6-18

Driver Personalisation System	6-19
Driver Personalisation System*	6-19
Warnings and Cautions For Using the Driver Personalisation System.....	6-19
How to Use the Driver Personalisation System.....	6-20

*Some models.

Fully Automatic Air-Conditioning

Air Vents

The location and the direction airflow exits the air vents changes depending on the air vent adjustment.

How to Use the Air Vents

Air vent open/closed

Move the dial fully in the fully open or fully closed direction.

Side Vents

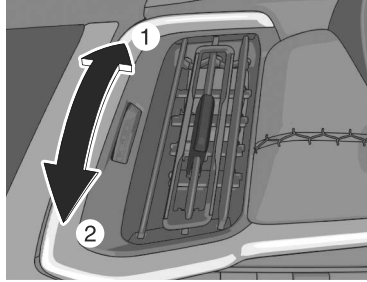

1. Open
2. Close

Centre Vents

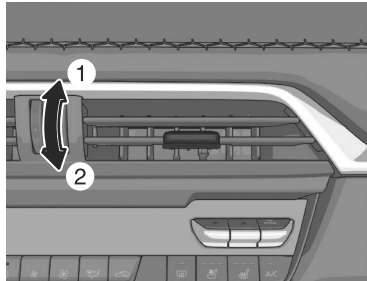

1. Open
2. Close

Rear Vents*

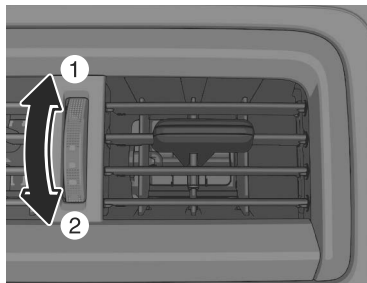

1. Open
2. Close

Airflow direction adjustment

Side Vents

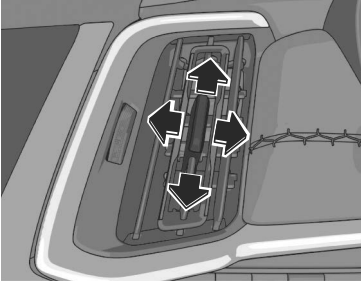

Centre Vents

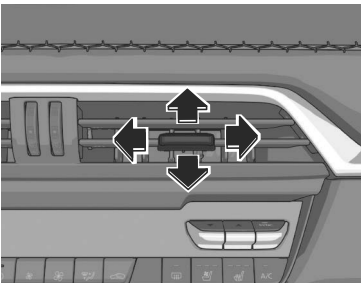

Rear Vents*

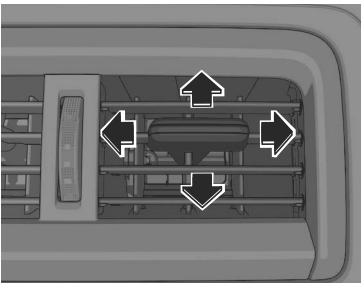

Airflow selection

Instrument panel Vents

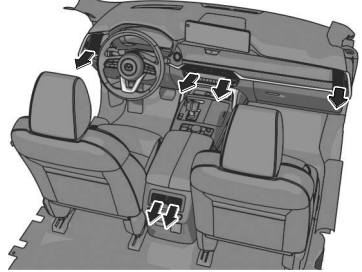

Instrument panel and Floor Vents

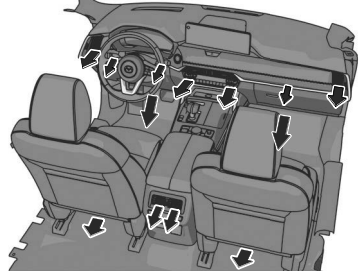

Floor Vents

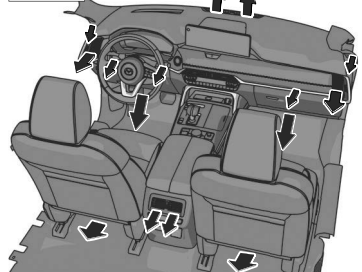

Fully Automatic Air-Conditioning

Defroster and Floor Vents

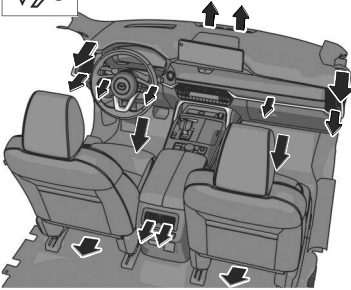

Defroster Vents

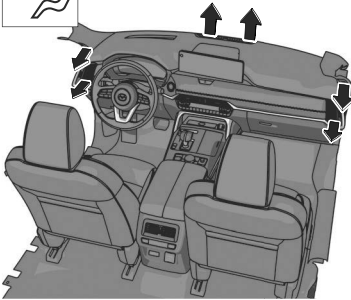

Fully Automatic Air-Conditioning

The following functions are automatically controlled according to the set temperature.

- Airflow temperature control
- Airflow amount control
- Airflow mode switching
- Recirculate/fresh air mode switching
- Air conditioning (cooling/dehumidifying functions) on/off
- Seat warmer level selection*
- Heated steering wheel operation*
- Seat ventilation level selection*

NOTE

To prevent cold airflow immediately after heating starts when the engine is cold, the airflow amount is decreased.

Fully automatic air-conditioning uses the sunlight and interior temperature sensors to control the temperature in the cabin by measuring interior and exterior temperatures, humidity, and sunlight. Do not cover the sunlight/interior temperature sensor.

Sunlight sensor

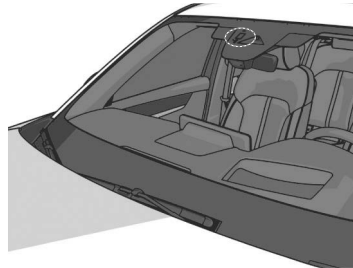

Interior temperature sensor

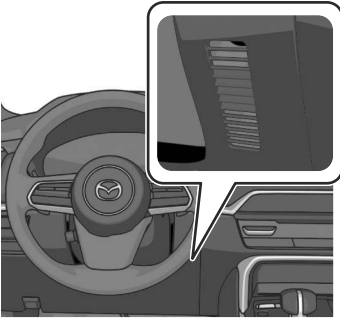

Fully Automatic Air-Conditioning

Fully Automatic Air-Conditioning Overview

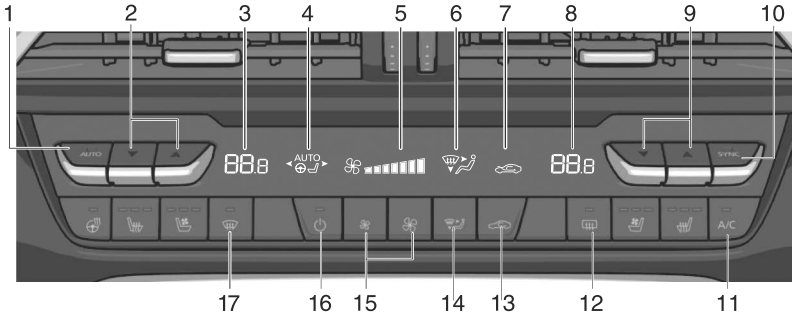

1. AUTO switch
2. Driver's side temperature setting switch
3. Driver's side temperature setting display
4. Linked auto-comfort display^{*1}
Refer to Convenient Ways to Use the Seat Warmer on page 6-14.
Refer to Convenient Ways to Use Heated Steering Wheel on page 6-16.
Refer to Convenient Ways to Use the Seat Ventilation on page 6-18.
5. Airflow display
6. Mode selector display
7. Air intake selector display
8. Front passenger's side temperature setting display
9. Front passenger's side temperature setting switch
10. SYNC (synchronized temperature) switch
11. A/C switch
12. Rear window defogger switch
13. Air intake selector switch
14. Mode selector switch
15. Fan control switch
16. Air-conditioning system power switch
17. Windscreen defroster switch

^{*1} The display differs depending on the air-conditioning systems, or whether or not the seat warmer, seat ventilation, and steering warmer are equipped.

How to Use the Fully Automatic Air-Conditioning

1. Start the engine.
- 2.

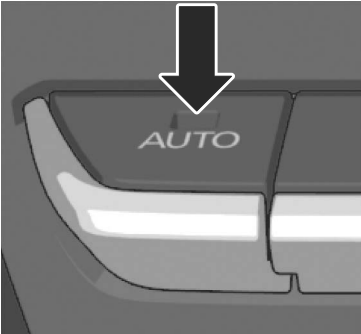

The AUTO switch indicator light turns on.

3. Press the temperature setting switch to set the desired temperature. Each function is automatically controlled according to the set temperature.
4. To stop the operation, press the air-conditioning system power switch.

NOTE

- The recommended set temperature is 22 °C (72 °F).
- If any mode selector switch, fan control switch, or windscreen defroster switch is operated during auto operation, the AUTO switch indicator light turns off. The functions for switches other than those operated will continue to operate in auto control.

Operating Each Switch

AUTO switch

Automatically controlled according to the set temperature.

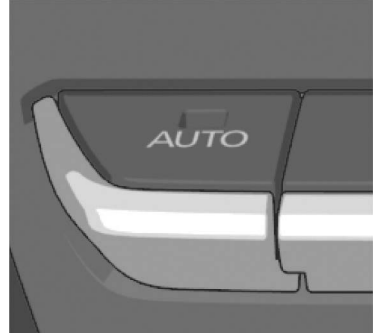

Temperature setting switch

How to increase the set temperature

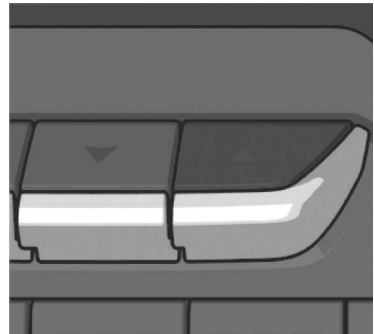

Fully Automatic Air-Conditioning

How to decrease the set temperature

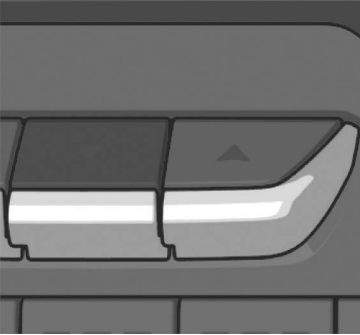

NOTE

- The set temperature changes in increments of 0.5 °C within a range of 15 °C (60 °F) and 29 °C (84 °F).
- The set temperature can be quickly adjusted by pressing and holding the temperature setting switch.
- When the temperature is set to the lower or upper limit, "Lo" or "Hi" is displayed.

SYNC (synchronized temperature) switch

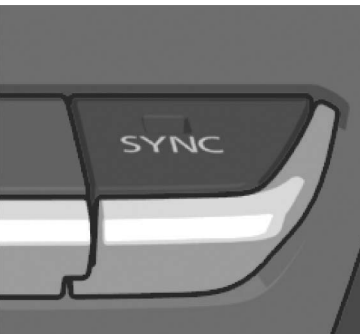

The mode switches between independent mode and interconnection mode each time the switch is pressed.

Independent mode (indicator light turned off)

The set temperature can be controlled independently for the driver's side and front passenger's side. Press the driver's side temperature setting switch or the front passenger's side temperature setting switch to control the temperature.

Interconnection mode (indicator light turned on)

The set temperature for the driver's side and front passenger's side is controlled simultaneously. Press the driver's side temperature setting switch to control the temperature.

NOTE

- The set temperature for the front passenger's side changes to that of the driver when independent mode is switched to interconnection mode.
- When the front passenger's side temperature setting switch is pressed while in interconnection mode (SYNC switch indicator light turned on), the mode switches to independent mode (SYNC switch indicator light turned off).

A/C switch



Fully Automatic Air-Conditioning

The cooling/dehumidifying function switches between on and off each time the switch is pressed. The indicator light turns on while the function is operating.

NOTE

The air conditioner may not operate when the ambient temperature falls to nearly 0 °C to protect the system.

Rear window defogger switch

Use to defog the rear window. Refer to How to Use the Rear Window Defogger Switch on page 5-90.

Air intake selector switch



The mode is switched between recirculate mode and fresh air mode each time the switch is pressed. The display indicates whether recirculate mode (↻) or fresh air mode (↻) is selected.

⚠ WARNING

Do not recirculate the air in the cabin during cold or rainy weather.

Recirculating the air in the cabin during cold and rainy weather is dangerous as it will cause the windows to fog up. Your vision will be hampered, which could lead to a serious accident.

Recirculate mode (↻)

Outside air is shut off. Air within the vehicle is recirculated. Use this position when going through tunnels, driving in congested traffic (high engine exhaust areas) or when quick cooling is desired.

Fresh air mode (↻)

Outside air is allowed to enter the cabin. Use this mode for ventilation or windscreen defrosting.

Mode selector switch



The desired airflow mode can be selected. The mode changes each time the switch is pressed. The selected mode is indicated on the display.

NOTE

To set the air vent to  press the windscreen defroster switch.

Fully Automatic Air-Conditioning

Fan control switch

How to increase the airflow amount



How to decrease the airflow amount



The airflow amount changes each time the switch is pressed. The airflow amount is indicated on the display. The airflow amount can be adjusted to 7 levels.

Air-conditioning system power switch (system on/off)



Switches the air-conditioning system on and off.

The indicator light turns on while the function is operating.

Windscreen defroster switch



Use to defrost the windscreen and front windows.

Automatically switches to fresh air mode. The indicator light turns on.

! WARNING

Do not lower the airflow temperature when defrosting the windscreen.

Otherwise, the outer side of the windscreen will frost causing reduced visibility which may lead to an accident.

NOTE

- For faster defrosting, do any of the following operations.
 - Operate the fan switch and increase the airflow amount.
 - Press the temperature setting switch to increase the airflow temperature.
- Be careful that the windows do not fog up when doing any of the following operations.
 - Switch to recirculate mode.
 - Turn off the air conditioner.

Seat Warmer*

The seat warmer warms the seat.

Warnings and Cautions For Using the Seat Warmer

WARNING

Be careful when using the seat warmer.

The heat from the seat warmer may be too hot for the following people and could cause a low-temperature burn.

- Infants, small children, elderly people, and physically challenged people
- People with delicate skin
- People who are excessively fatigued
- People who are intoxicated
- People who have taken sleep-inducing medicine such as sleeping pills or cold medicine

Do not use the seat warmer with anything having high moisture-retention ability such as a blanket or cushion on the seat.

The seat may be heated excessively and cause a low-temperature burn.

Do not use the seat warmer even when taking a short nap in the vehicle.

The seat may be heated excessively and cause a low-temperature burn.

Do not place heavy objects with sharp projections on the seat, or insert needles or pins into it.

This could cause the seat to become excessively heated and result in injury from a minor burn.

! CAUTION

- Do not use organic solvents to clean the seat. It may damage the seat surface and the heater.
- **(rear)**
Before folding a rear seatback, make sure that the rear seat warmer switch is off. If a rear seatback is folded while the rear seat warmer is in operation, it may heat the seat excessively and damage the seat surface.

How to Use the Seat Warmer

1. Start the engine.
2. **Front**

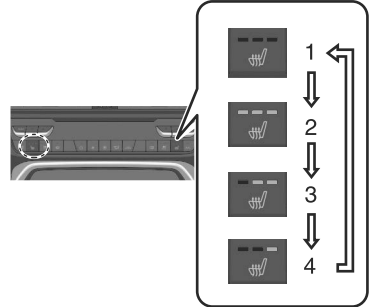

1. OFF
 2. High
 3. Mid
 4. Low
- Rear**

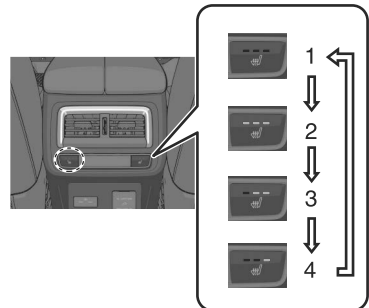

1. OFF
2. High
3. Mid
4. Low

The indicator light in the seat warmer switch turns on according to the set temperature. The set temperature changes each time the seat warmer switch is pressed.

Seat Warmer

NOTE

If the engine is stopped while the seat warmer is operating in manual mode, the seat warmer does not turn on automatically the next time the engine is started. To turn the seat warmer on, press the switch again. In addition, the rear seat warmer operation stops automatically after the seat warmers have operated for a certain period of time.

Convenient Ways to Use the Seat Warmer

The seat temperature for front seat can be automatically controlled (auto mode) at 4 levels (High, Mid, Low, OFF) according to the conditions in the cabin.

The seat warmer can be operated in conjunction with auto mode for the air-conditioning system.

1. Turn on the "Occupant Comfort"
Refer to Mazda Connect Owner's Manual or consult an expert repairer (we recommend an Authorised Mazda Repairer).
2. Press the AUTO switch for the air-conditioning system.

NOTE

- If the front passenger's seat belt is unfastened, the front passenger's seat warmer turns off.
- If any of the following switch operations is performed during auto mode or the auto operation of the air-conditioning system is cancelled, the seat warmer switches from auto mode to manual mode.
 - Seat warmer switch is pressed
 - Seat ventilation switch is pressed

When the seat warmer switch/seat ventilation switch is pressed, only the seat on the side where the switch was pressed switches to manual mode.

To return to auto operation, press the AUTO switch for the air-conditioning system.

- While operating in auto mode, the



(with heated steering wheel)/



(without heated steering wheel)
is displayed.

Heated Steering Wheel*

The grips on the left and right of the steering wheel can be warmed up.

Warnings and cautions For Using the Heated Steering Wheel

WARNING

The following types of persons should be careful not to touch the steering wheel. Otherwise, it could cause a low-temperature burn.

- Infants, small children, elderly people, and physically challenged people
- People with delicate skin
- People who are excessively fatigued
- People who are intoxicated
- People who have taken sleep-inducing medicine such as sleeping pills or cold medicine

How to Use Heated Steering Wheel

Using the Heated Steering Wheel

1. Start the engine.
- 2.

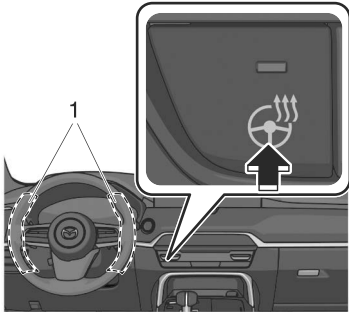

1. Heating area
The indicator light in the heated steering wheel switch turns on.

NOTE

The heated steering wheel operates for a certain period of time and then stops automatically.

Turning Off the Heated Steering Wheel

Press the heated steering wheel switch. The heated steering wheel stops and the indicator light in the switch turns off.

Convenient Ways to Use Heated Steering Wheel

The steering warmer can be automatically (auto mode) turned on/off depending on the conditions in the cabin.

The steering warmer can be operated in conjunction with auto mode for the air-conditioning system.

1. Turn on the "Occupant Comfort"
Refer to Mazda Connect Owner's Manual or consult an expert repairer (we recommend an Authorised Mazda Repairer).
2. Press the AUTO switch for the air-conditioning system.

NOTE

- If the heated steering wheel switch is pressed during auto mode or the auto operation of the air-conditioning system is cancelled, the heated steering wheel switches from auto mode to manual mode. To return to auto operation, press the AUTO switch for the air-conditioning system.
- If the vehicle power is switched OFF while the heated steering wheel is operating in auto mode, the heated steering wheel operates in auto mode again the next time the vehicle power is switched ON.

Seat Ventilation*

The seat ventilation uses the fans installed on the seats to draw air around the seat surface and ventilate them.

Warnings and cautions For Using the Seat Ventilation

CAUTION

- Do not use organic solvents to clean the seat. It may damage the seat surface and the seat ventilation parts.
- Do not place heavy objects with sharp projections on the seat, or insert needles or pins into it.

How to Use the Seat Ventilation

1. Start the engine.
- 2.

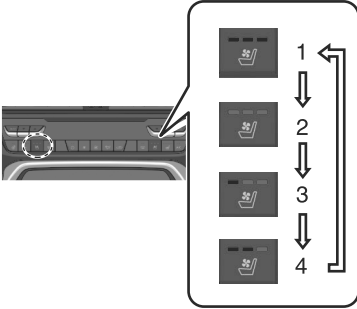

1. OFF
2. High
3. Mid
4. Low

While the seat ventilation is operating, the indicator light in the seat ventilation switch turns on according to the set mode.

NOTE

If the engine is stopped while the seat ventilation is operating in manual mode, the seat ventilation does not turn on automatically the next time the engine is started. To turn the seat ventilation on, press the switch again.

Convenient Ways to Use the Seat Ventilation

The fan operation for front seat is automatically controlled at 4 levels (High, Mid, Low, and OFF) according to the conditions in the cabin.

The seat ventilation can be operated in conjunction with auto mode for the air-conditioning system.



1. Turn on the "Occupant Comfort"
Refer to Mazda Connect Owner's Manual or consult an expert repairer (we recommend an Authorised Mazda Repairer).
2. Press the AUTO switch for the air-conditioning system.

NOTE

- If the front passenger's seat belt is unfastened, the front passenger's seat ventilation turns off.
- If any of the following switch operations is performed during auto mode or the auto operation of the air-conditioning system is cancelled, the seat ventilation switches from auto mode to manual mode.
 - Seat warmer switch is pressed
 - Seat ventilation switch is pressed

When the seat warmer switch/seat ventilation switch is pressed, only the seat on the side where the switch was pressed switches to manual mode.

To return to auto operation, press the AUTO switch for the air-conditioning system.

- While operating in auto mode, the  (with heated steering wheel)/
 (without heated steering wheel) is displayed.

Driver Personalisation System*

The Driver Personalisation System recognises the driver using the camera inside the vehicle and automatically restores the various driver settings that have been stored.

The following 2 functions have been added depending on the grade and specification.

Ideal Driving Position Assist*

This function makes an overall determination of the driver's physique based on the information from the camera in the vehicle and the input height, and automatically adjusts to the recommended driving position.

Entry/Exit Assist*

This function automatically moves the seat and the steering wheel so that the driver can easily enter and exit the vehicle.

Warnings and Cautions For Using the Driver Personalisation System

CAUTION

Do not allow a hand, fingers, or feet to come close to the area under or around the seat or steering wheel when the seat or steering wheel is automatically moving by the driver personalisation system. Otherwise, your hand, fingers, or feet could be injured.

How to Use the Driver Personalisation System

NOTE

- In the following cases, the driver may not be registered or recognised correctly.
 - You are wearing sunglasses, a mask, or other accessories.
 - There is an obstruction between your face and the camera.
- Looking forward or at the Mazda Connect screen will facilitate driver recognition.
- If the vehicle power is switched ON during recognition, the driver will be recognised as a guest. If the vehicle power is switched ON without opening/closing the door even once, the information of the previously recognised driver is taken over.
- If the recognition is difficult, reprogramme the data. Two types of faces can be programmed, such as when wearing glasses or contact lenses.
- If people with similar faces are programmed, they may be recognised incorrectly.
Refer to Driver Monitoring Camera on page 5-145

Programming

1. Switch the vehicle power ON.
2. Select "Settings" from the Mazda Connect home screen.
3. Select "Driver Personalization System".
4. Select "Add New Driver".
Operate according to the Mazda Connect screen.

NOTE

When the door is closed and "Add New Driver" is displayed on the Mazda Connect home screen, follow the instructions on the screen.

5. (Vehicles with Ideal Driving Position Assist)

Programme the driver's height according to the Mazda Connect screen.

The following items are automatically adjusted.

- Driver's seat position (Angle, forward and back positions, entire height, front end height)
- Active driving display (Display height)
- Outer mirror angle
- Steering wheel position (forward and back positions, height)

NOTE

- Under the following conditions, the Ideal Driving Position Assist is cancelled.
 - The switch is operated due to the position adjustment of the driver's seat, the steering wheel, the outer mirrors, or the active driving display.
 - The key lock button or unlock button is operated.
 - The vehicle moves.
 - The selector lever is shifted to a position other than P.
- 6. Follow the Mazda Connect screen to complete the programming.

System Operation

When Entering the Vehicle

Sit in the driver's seat and close the door.

Matching of the driver's information with the programmed information begins.

The recognition result is displayed on the screen.

If a confirmation message is displayed on the Mazda Connect screen, follow the message to complete the operation.

The various driver's settings that have been programmed are automatically restored.

NOTE

- If the outer mirror angles are adjusted close to the limits of their range of motion, the outer mirror angles may not be restored correctly.
- When the adjustment to the stored driving position has been completed, a sound is not activated.
- Under the following conditions, the driving position adjustment is cancelled automatically.
 - The switch is operated due to the position adjustment of the driver's seat, the steering wheel, the outer mirrors, or the active driving display.
 - The key lock button or unlock button is operated.
 - The vehicle moves.
 - The selector lever is shifted to a position other than P.

When Exiting the Vehicle

Unfasten the seat belt and switch the vehicle power OFF.

The air-conditioning setting status and the personalisation features are stored at the time the vehicle power is switched OFF.

(Vehicles with Entry/Exit Assist)

The seat and the steering wheel move when all of the following conditions are met.

- The vehicle is in a programmed driving position or in a position where the vehicle was driven for a certain period of time after adjusting the driving position.
- The vehicle power is switched OFF.
- The driver's seat belt is unfastened.

NOTE

- The air-conditioning setting status and the personalisation features are also stored when the drivers are switched or when another programmed driver is selected.
- The air-conditioning system operates at the current setting without restoring the stored values if any of the following conditions occurs.
 - The windscreen defrosting was operating.
 - The ambient temperature is significantly different from the previous time of entering the vehicle.
 - A certain number of days have passed since the previous time of entering the vehicle.
- If the driver's seat belt is unfastened about 40 seconds after the vehicle power is switched OFF, the Entry/Exit Assist may not operate.
- The Entry/Exit Assist may not operate depending on the position of the seat and the steering wheel.

Driver Personalisation System

- The amount of seat movement and the seat and the steering wheel movement on/off can be changed. Refer to Settings section in the Mazda Connect Owner's Manual or consult an Authorised Mazda Repairer.
- In the following cases, the Entry/Exit Assist is cancelled.
 - A switch is operated due to the position adjustment of the driver's seat, steering wheel, or outer mirrors.
 - The key lock button or unlock button is operated.

Editing and Deleting the Programming Content

Switch the vehicle power ON.
Select "Settings" from the Mazda Connect home screen.
Select "Driver Personalization System".
Operate according to the Mazda Connect screen.

Setting the System to Inoperable

This can be set by operating Mazda Connect.
Refer to Mazda Connect Owner's Manual or consult an expert repairer (we recommend an Authorised Mazda Repairer).

- Mazda Connect**..... 7-4
 Mazda Connect..... 7-4
 Warnings and Cautions for Using the Mazda Connect..... 7-5
 How to Use the Mazda Connect..... 7-6
 How to Use the Commander Switch..... 7-8
 How to Use the Audio Remote Control Switch..... 7-12
 How to Use the Voice Recognition Function..... 7-15
 Appendix..... 7-19
- Emergency Call System*** 7-24
 Emergency Call System..... 7-24
 Warnings and Cautions for Using the Emergency Call System 7-28
 How to Use the Emergency Call System..... 7-30
- Mazda ERA-GLONASS*** 7-36
 Mazda ERA-GLONASS..... 7-36
 Warnings and Cautions for Using Mazda ERA-GLONASS..... 7-38
 How to Use Mazda ERA-GLONASS..... 7-40
- Storage Compartments**..... 7-48
 Warning and Cautions for Using the Storage Compartments 7-48
- Cup Holders**..... 7-49
 Warnings and Cautions for Using the Cup Holders..... 7-49
 Cup Holders..... 7-49
- Bottle Holder**..... 7-50
 Warnings and Cautions for Using the Bottle Holder..... 7-50
 Bottle Holder..... 7-50
- Glove Compartment**..... 7-51
 How to Use the Glove Compartment..... 7-51
- Coin Box**..... 7-52
 How to Use the Coin Box* 7-52
- Centre Console**..... 7-53
 How to Use the Centre Console..... 7-53
- Overhead Console**..... 7-54
 How to Use the Overhead Console* 7-54
- Rear Coat Hooks**..... 7-55
 Warning and Cautions for Using the Rear Coat Hooks..... 7-55
 How to Use the Rear Coat Hooks..... 7-55
- Luggage Compartment**..... 7-56
 Luggage Compartment..... 7-56

How to Use the Luggage Compartment.....	7-56
Sunvisor.....	7-57
How to Use the Sunvisor.....	7-57
Vanity Mirror.....	7-58
How to Use the Vanity Mirrors.....	7-58
Interior Lights.....	7-59
Illuminated Entry System.....	7-59
How to Use the Illuminated Entry System.....	7-59
How to Use the Overhead Lights.....	7-60
How to Use the Map Lights.....	7-61
How to Use the Door Courtesy Lights*.....	7-62
How to Use the Luggage Compartment Lights.....	7-62
How to Use the Ambient Lights*.....	7-63
Accessory Sockets.....	7-64
Accessory Sockets.....	7-64
Warnings and Cautions When Using the Accessory Socket.....	7-64
How to Use the Accessory Socket.....	7-65
AC Power Outlet (220 V/150 W)*.....	7-65
Warnings and Cautions When Using the AC Power Outlet (220 V/150 W).....	7-66
How to Use the AC Power Outlet (220 V/150 W).....	7-67

USB Power Outlet*.....	7-68
Warnings and Cautions When Using the USB Power Outlet.....	7-68
How to Use the USB Power Outlet.....	7-69

Wireless Charger (Qi).....	7-70
Wireless Charger (Qi)*.....	7-70
Warnings and Cautions When Using the Wireless Charger (Qi).....	7-70
How to Use the Wireless Charger (Qi).....	7-72
Convenient Ways to Use the Wireless Charger (Qi).....	7-73

Assist Grip.....	7-74
Warnings and Cautions When Using the Assist Grips.....	7-74
Using the Assist Grips.....	7-74

Luggage compartment cover.....	7-75
Luggage Compartment Cover*.....	7-75
Warnings and Cautions for Using the Luggage compartment cover.....	7-75
How to Use the Luggage Compartment Cover.....	7-76

Partition Net.....	7-77
Partition Net*.....	7-77
Warnings and Cautions For Using the Partition Net.....	7-77
How to Use the Partition Net.....	7-78

Towing.....	7-81
Towing (Europe/Russia/Israel/ South Africa).....	7-81
Warnings and Cautions for Using the Towing.....	7-81
How to Use the Towing.....	7-83
Accessories.....	7-89
Warnings and Cautions For Using the Accessories.....	7-89
Floor Mat.....	7-90
Warnings and Cautions For Using the Floor Mat.....	7-90

Malfunction Diagnosis	
Connector.....	7-91
Malfunction Diagnosis	
Connector.....	7-91
Spare Tyre and Tool Storage.....	7-92
Jack*.....	7-92
Spare Tyre*.....	7-92
Screwdriver and Wrench*.....	7-94

Mazda Connect

This manual only indicates a part of the information for Mazda Connect. For details, check the Web owner's manual at the Mazda site for each country and region.

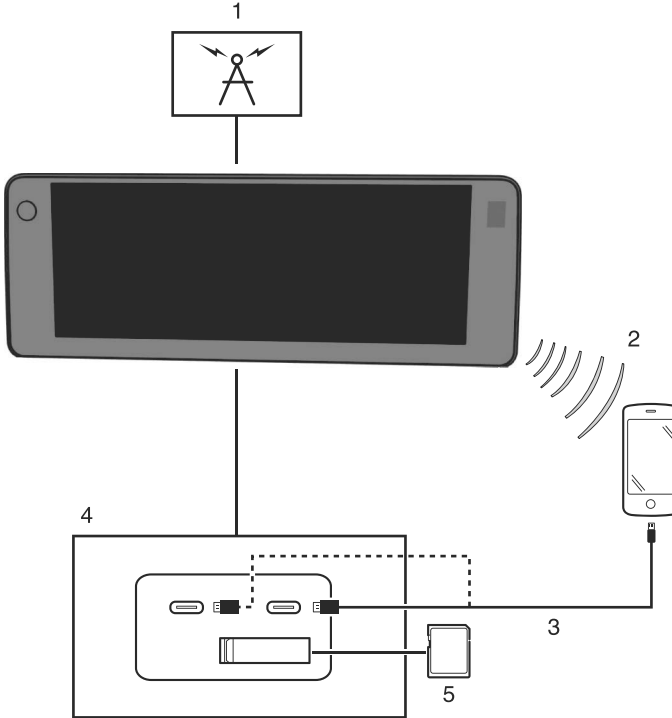

1. Radio
2. Bluetooth® Audio/Hands-Free Call/SMS (Short Message Service)
3. USB Audio/USB Video
4. USB port*¹/SD card slot*²
5. SD card (Navigation system)*

*¹ The position and the type of the USB port differ depending on the specification.

*² The SD card slot is for the navigation system only. For vehicles with the navigation system, the SD card (Mazda genuine) with stored map data is inserted into the SD card slot and used.

Warnings and Cautions for Using the Mazda Connect

WARNING

Always adjust Mazda Connect while the vehicle is stopped:

Do not adjust Mazda Connect with the Commander switch while driving the vehicle. Adjusting Mazda Connect with the Commander switch while driving the vehicle is dangerous as it could distract your attention from the vehicle operation which could lead to a serious accident.

Even if the audio remote control switches are equipped on the steering wheel, learn to use the switches without looking down at them so that you can keep your maximum attention on the road while driving the vehicle.

Do not allow the connection plug cord to get tangled with the selector lever:

Allowing the plug cord to become tangled with the selector lever is dangerous as it could interfere with driving, resulting in an accident.

Do not adjust a mobile device or a similar product while driving the vehicle:

Adjusting a mobile device or a similar product while driving the vehicle is dangerous as it could distract your attention from the vehicle operation which could lead to a serious accident. Always adjust a mobile device or a similar product while the vehicle is stopped.

CAUTION

For the purposes of safe driving, adjust the audio volume to a level that allows you to hear sounds outside of the vehicle including car horns and particularly emergency vehicle sirens.

How to Use the Mazda Connect



Information

Fuel Efficiency Monitor:

Monitor fuel efficiency in real time and view fuel efficiency history.

Vehicle Status Monitor:

View important vehicle maintenance messages, information, and intervals.

Entertainment

FM

AM

DAB*

Bluetooth

USB1 Audio/USB2 Audio

USB1 Video/USB2 Video

Audio Off

Notifications

Displays text messages received by the mobile device paired to Mazda Connect and notifications from the vehicle.

Communication

By connecting your mobile device, such as a Smartphone, to Mazda Connect via Bluetooth®, you can use the hands-free call and short message functions.

Navigation

The navigation system (vehicles with navigation system) can be used when the SD card for the navigation system is inserted.

If the SD card for the navigation system is not inserted, the compass indicating the direction in which the vehicle is moving is displayed. The compass may not indicate the correct bearing when the vehicle is stopped or travelling at a slow speed. For the navigation system operation, refer to the navigation system manual.

Settings

You can change the settings for the Mazda Connect screen, sound settings, and the vehicle functions.

In-Vehicle Displays:

Configures settings and content for all in-vehicle displays.

Sound Settings:

Configures the in-vehicle listening experience.

Safety Settings:

Configures safety and driver assistance features.

Vehicle Settings:

Configures vehicle convenience features.

Connectivity Settings:

Configures Bluetooth and other device connectivity settings.

Driver Personalization System:

Registers a driver or edits the driver information.

System Settings:

Configures language, time, and other general settings.

Apple CarPlay

You can use Apple CarPlay by connecting an iPhone compatible with Apple CarPlay.

Android Auto

You can use Android Auto™ by connecting an Android™ Smartphone compatible with Android Auto™.

NOTE

The explanation of functions described in this manual may differ from the actual operation, and the shapes of screens and buttons and the letters and characters displayed may also differ from the actual appearance. Additionally, depending on future software updates, the content may successively change without notice.

How to Use the Commander Switch

The commander switch can be used to switch to each function and to operate each function.

Set the palm of your hand on the commander knob so that your fingers can touch each of the switches.

You can switch the screens without having to look down at your hand.

NOTE

For safety reasons, some operations are disabled while driving the vehicle.

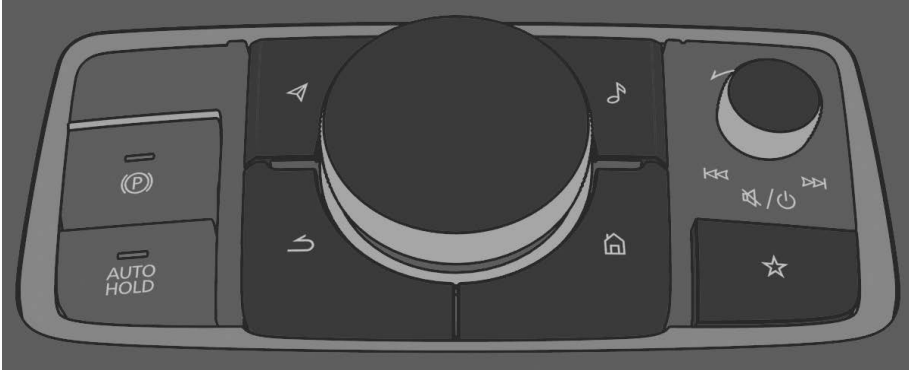

The shape of the switches varies depending on the specifications.

Commander knob (selection)

Rotate or slide the commander knob to highlight/select the on-screen functions you want to use.

Commander knob (select)

Depress the commander knob to select the desired on-screen function you want to use.

Entertainment button

The audio source screen last used is displayed.

(During Apple CarPlay or Android Auto™ music playback)

Displays the Apple CarPlay or Android Auto™ now playing screen.

Volume knob

Volume adjustment

Adjust the volume by turning the volume knob.

If you adjust the volume during voice guidance, the volume of the voice guidance will change.

If you adjust the volume during a hands-free call, the conversation volume will change.

Press the volume knob to mute/pause the audio. Press the knob again to resume.

Power off/on

Press and hold to turn off the Mazda Connect power and turn off the screen.

Press again to turn on the Mazda Connect power.

NOTE

- If you press the volume knob to mute an audio source which can be paused, such as Apple CarPlay, USB audio, or Bluetooth® audio, while it is playing, the song playback pauses. Press the volume knob again to cancel the mute and the pause at the same time.
- When the Mazda Connect power is turned off and the commander switch is pressed, the Mazda Connect power turns on.

Selecting a radio station

(FM/AM radio)

Radio stations saved to your Favourites can be selected by sliding the volume knob left (SEEK DOWN)/right (SEEK UP) while listening to FM/AM. The station will change each time you slide the volume knob.

If you want to manually tune to the next available station before or after the currently selected station, slide and hold the volume knob left (SEEK DOWN) or right (SEEK UP) until you hear a beep and the tuner will select the next available station.

(DAB radio)*

You can call up radio stations registered to your Favourites by sliding the volume knob left/right while listening to DAB radio. The radio stations change each time you slide the volume knob.

In addition, the service switches to the next service when you continue sliding the knob to the right until you hear a beep, and it switches to the previous service when you continue sliding the knob to the left. If there is no next or previous service in the selected Ensemble, Ensemble switches.

Playback Control

Music and video files can be cued when listening to stored content via USB, Bluetooth®, and audio or video.

Slide the volume knob right to skip to the next track or slide it to the left to go back to the previous track. You can also slide and hold the volume knob to fast forward or rewind the track.

Favourites button

Displays the favourites screen.

Press and hold to register AM/FM stations, contacts, navigation destinations, or any highlighted menu items to create easily accessible shortcuts.

Home button

Displays the home screen.

(While Apple CarPlay or Android Auto™ is displayed)

Displays the Apple CarPlay or Android Auto™ home screen.

(While Apple CarPlay or Android Auto™ is connected)

Press and hold while the Mazda Connect screen is displayed to switch the screen from Mazda Connect to Apple CarPlay or Mazda Connect to Android Auto™. In addition, press and hold while the Apple CarPlay or Android Auto™ screen is displayed to switch to the Mazda Connect screen.

Back button 

Returns to previous screen.

Map button 

Displays the navigation screen (vehicles with navigation system).

In order for the navigation system to function, the SD card for the navigation system is required.

If the SD card for the navigation system is not inserted, the compass indicating the direction in which the vehicle is moving is displayed.

For the navigation system operation, refer to the navigation system manual.

(During Apple CarPlay or Android Auto™ route guidance)

Displays the Apple CarPlay or Android Auto™ map screen.

NOTE

With an active Mazda Navigation route, pressing the Map button will repeat the navigation voice guidance.

How to Use the Audio Remote Control Switch

The audio remote control switch is on the left side of the steering wheel. You can operate basic audio functions, pick up/hang up the phone, or activate voice control using the switch.

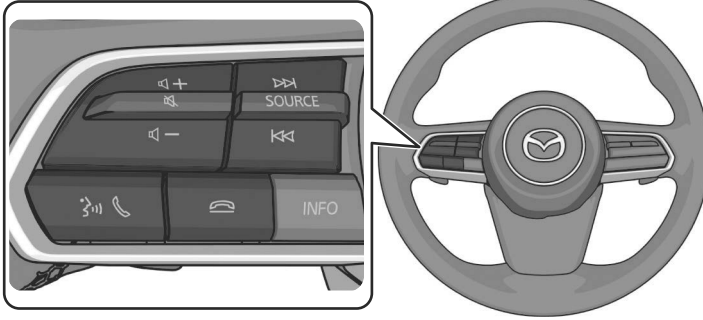

The shape of the switches may differ depending on the specifications.

Volume adjustment button

Press the (+) or (-) button to adjust the volume.

If you adjust the volume during voice guidance, the volume of the voice guidance will change.

If you adjust the volume during a hands-free call, the conversation volume will change.

Seek Switch (SEEK UP) / (SEEK DOWN)

Selecting a radio station

(FM/AM radio)

Radio stations saved to your Favourites can be selected by pressing the seek switch while listening to FM/AM radio. The station will change to the previous or next favourite station each time you press the seek switch. If you want to manually tune to the next available station before or after the currently selected station, press and hold the seek switch until it beeps and the tuner will select the next available station.

(DAB radio)*

You can call up radio stations registered to your Favourites by pressing the seek switch while listening to DAB radio. The radio station changes each time you press the seek switch.

In addition, if you press and hold the seek switch until you hear a beep, the service switches to the next or previous service. If there is no next or previous service in the selected Ensemble, Ensemble switches.

Playback Control

Music and video files can be cued when listening to stored content via USB, Bluetooth®, and audio or video.

Slide the volume knob right to skip to the next track or slide it to the left to go back to the previous track. You can also slide and hold the volume knob to fast forward or rewind the track.

SOURCE button:

The audio source can be switched each time the button is pressed. In addition, when the button is pressed and held, the current audio source is muted and the audio source selection screen is displayed.

(During Apple CarPlay or Android Auto™ playback)

Press and hold the SOURCE button to mute the current audio source.

Hang-up button

(During a call)

Press the button to end the call.

(While receiving a call)

Press the button to refuse a call.

Talk/Pick-up button

(While receiving a call)

Press the button to answer the call.

Mute button

Press the button to mute.
Press it again to cancel the mute.

NOTE

If you press the mute button to mute an audio source which can be paused, such as Apple CarPlay, USB audio, or Bluetooth® audio, while it is playing, the song playback pauses. Press the mute button again to cancel the mute and the pause at the same time.

How to Use the Voice Recognition Function

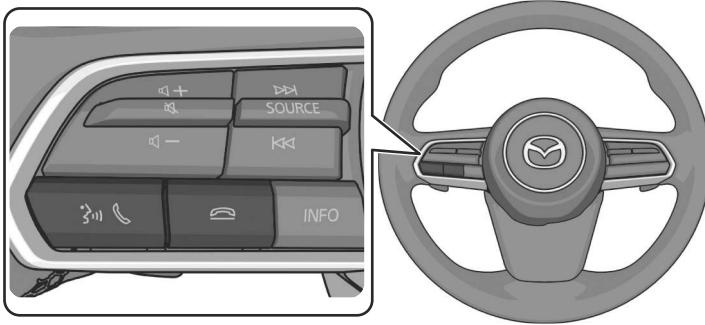

The shape of the switches may differ depending on the specifications.

Talk/Pick-up button

When the button is pressed, the voice recognition top screen is displayed and the voice recognition is activated.

(While voice guidance is being announced)

Press the button to skip the voice guidance.

Hang-up button

Press the button to end the voice recognition.

Voice recognition activation

When the talk/pick-up button on the audio remote control switch is pressed, top screen of the voice recognition will be displayed.

NOTE

When an Apple CarPlay or Android Auto™ compatible device is connected, the Mazda Connect voice recognition system is disabled to allow the use of Siri or Android Auto™ voice recognition at any time with the talk/pick-up button.

Commands usable at any time

“Help” - Can be used to check for usable voice commands.

“Back” - Returns to the previous screen. When a voice command is spoken while on the telephone number input screen, the content that was previously input is deleted.

“Cancel”- The voice recognition is ended.

Ending voice recognition

Do any one of the following operations:

- Press the hang-up button.
- Press and hold the talk/Pick-up button.
- Say the word, "Cancel".

Convenient operating tips for using the voice recognition function

Examples of effective voice commands in various categories are displayed on top screen of the voice recognition.

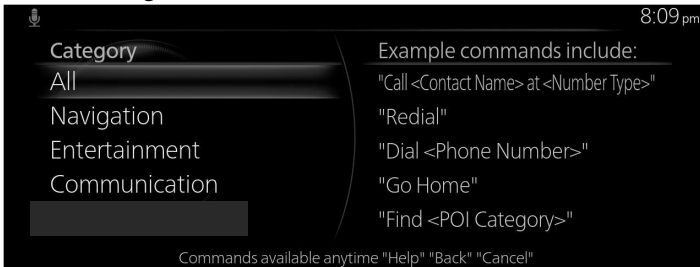

NOTE

- The voice command examples shown in this manual are only a partial list of the available commands. Some commands may be unusable depending on the specifications.
- Some commands cannot be used depending on the device connection conditions and the use conditions.
- When the Barge-In setting is on, voice commands can be made even while the voice guidance is being announced. For details on Barge-In, refer to the System Settings section in the Mazda Connect Owner's Manual.
- For details on voice commands which can be used on the navigation screen, refer to the navigation system manual.

To prevent misunderstood voice commands, be aware of the following points:

- Connect your mobile phone to Bluetooth® before operating the mobile phone using voice recognition.
- After pressing the talk/pick-up button, wait for the beep before speaking a command.
- Speaking in a slightly louder voice will improve voice recognition, but an excessively loud voice is unnecessary. Try to speak in a slightly louder voice than when talking to other passengers in the vehicle.
- You do not need to speak slowly. Speak at a normal speed.
- When calling a person in the device's phone book, the recognition rate increases the longer the name is. Errors may occur with names that are short such as "Mama", "Home", or "Wife".
- Speak clearly, without pausing between words or numbers.

- Voice commands other than those specified, cannot be recognised. Speak in the wording specified by the voice commands.
- It is not necessary to face the microphone or approach it. Speak the voice commands while maintaining a safe driving position.
- Close the windows and the panorama sunroof* to reduce loud noises from outside the vehicle and to prevent the airflow of the air-conditioning system from being a disturbance when using Bluetooth® Hands-Free.
- Make sure that the air flow from the air conditioner is not blowing on the microphone.
- If the voice recognition is poor with the guidance volume set to high, set the Barge-In to OFF.

Examples of available voice commands

The specified name and number are put into the {}.

Common

- Back
- Help (You can listen to help guidance at each screen.)
- {Line Number} (You can select the line number on the screen.)
- Next Page
- Previous Page
- Cancel

Menu

- All
- Navigation
- Entertainment
- Communication

Setting

- Voice Recognition Settings
- Display Off

Music

- Play Artist (You can also use "Play Artist {Artist name}").
- Play Album (You can also use "Play Album {Album Name}").
- Play Playlist (You can also use "Play Playlist {Playlist Name}").
- Play Song (You can also use "Play Song {Song Name}").
- Play Audiobook (You can also use "Play Audiobook {Audiobook Name}").
- Play Podcast (You can also use "Play Podcast {Podcast Name}").

Radio

- Tune to {Frequency} AM
- Tune to {Frequency} FM
- Tune to {AM Station Name}
- Tune to {FM Station Name}

- Tune to DAB {DAB Station Name}

Source

- Change Source (You can also use “Change Source to USB”^{*1} and “USB”^{*1}.)
- Audio OFF (You can also use “Change Source to Audio OFF”.)

Phone

- Dial Phone Number (You can also use “Dial {Phone Number}”.)
- Call History
- Call a Contact (You can also use “Call {Contact Name}” and “Call {Contact Name} at {Number Type}”.)
- Redial

^{*1} Audio source names other than “USB” can also be used as follows:
Bluetooth/AM/FM/DAB/USB1 Audio/USB2 Audio/USB1 Video/USB2 Video

Appendix

Gracenote® Database

When connecting a USB audio device or Bluetooth® audio device to this unit and playing audio, the unit searches the database stored in the vehicle for the album art. If there is a match in the vehicle's database compilation to the music being played, the album art is displayed. The database information stored in this device uses database information in the Gracenote® music recognitions service.

Apple CarPlay



➤ YOU EXPRESSLY ACKNOWLEDGE AND AGREE THAT USE OF APPLE CARPLAY ("THE APPLICATION") IS AT YOUR SOLE RISK AND THAT THE ENTIRE RISK AS TO SATISFACTORY QUALITY, PERFORMANCE, ACCURACY AND EFFORT IS WITH YOU TO THE MAXIMUM EXTENT PERMITTED BY APPLICABLE LAW, AND THAT THE APPLICATION AND INFORMATION ON THE APPLICATION IS PROVIDED "AS IS" AND "AS AVAILABLE", WITH ALL FAULTS AND WITHOUT WARRANTY OF ANY KIND, AND MAZDA HEREBY DISCLAIMS ALL WARRANTIES AND CONDITIONS WITH RESPECT TO THE APPLICATION AND INFORMATION ON THE APPLICATION, EITHER EXPRESS, IMPLIED OR STATUTORY, INCLUDING, BUT NOT LIMITED TO, THE IMPLIED WARRANTIES AND/OR CONDITIONS OF MERCHANTABILITY, SATISFACTORY QUALITY, FITNESS FOR A PARTICULAR PURPOSE, ACCURACY, QUIET ENJOYMENT, AND NONINFRINGEMENT OF THIRD PARTY RIGHTS.

AS EXAMPLES, AND WITHOUT LIMITATION, MAZDA DISCLAIMS ANY WARRANTY REGARDING THE ACCURACY OF DATA PROVIDED BY THE APPLICATION, SUCH AS THE ACCURACY OF DIRECTIONS, ESTIMATED TRAVEL TIME, SPEED LIMITS, ROAD CONDITIONS, NEWS, WEATHER, TRAFFIC, OR OTHER CONTENT PROVIDED BY APPLE, ITS AFFILIATES, OR THIRD PARTY PROVIDERS; MAZDA DOES NOT GUARANTEE AGAINST LOSS OF APPLICATION DATA, WHICH MAY BE LOST AT ANY TIME; MAZDA DOES NOT GUARANTEE THAT THE APPLICATION OR ANY SERVICES PROVIDED THROUGH THEM WILL BE PROVIDED AT ALL TIMES OR THAT ANY OR ALL SERVICES WILL BE AVAILABLE AT ANY PARTICULAR TIME OR LOCATION. FOR EXAMPLE, SERVICES MAY BE SUSPENDED OR INTERRUPTED WITHOUT NOTICE FOR REPAIR, MAINTENANCE, SECURITY FIXES, UPDATES, ETC., SERVICES MAY BE UNAVAILABLE IN YOUR AREA OR LOCATION, ETC.

IN ADDITION, YOU UNDERSTAND THAT CHANGES IN THIRD PARTY TECHNOLOGY OR GOVERNMENT REGULATION MAY RENDER THE SERVICES AND/OR APPLICATIONS OBSOLETE AND/OR UNUSABLE. TO THE EXTENT NOT PROHIBITED BY LAW, IN NO EVENT SHALL MAZDA OR ITS AFFILIATES BE LIABLE FOR PERSONAL INJURY, OR ANY INCIDENTAL, SPECIAL, INDIRECT OR CONSEQUENTIAL DAMAGES WHATSOEVER, INCLUDING, WITHOUT LIMITATION, DAMAGES FOR LOSS OF PROFITS, CORRUPTION OR LOSS OF DATA, FAILURE TO TRANSMIT OR RECEIVE ANY DATA, BUSINESS INTERRUPTION OR ANY OTHER COMMERCIAL DAMAGES OR LOSSES, ARISING OUT OF OR RELATED TO THE APPLICATION OR YOUR USE OF OR INABILITY TO USE THE APPLICATION OR INFORMATION ON THE APPLICATION.

- When using Apple CarPlay, please avoid distraction and use Apple CarPlay responsibly.
Stay fully aware of driving conditions and always obey applicable laws.

NOTE

- Apple CarPlay is provided by Apple and its use is subject to your agreement to the Apple CarPlay terms of use, which are included as part of the Apple iOS terms of use.
- When using Apple CarPlay, location, speed, and other vehicle data is transferred to your iPhone. For further details, refer to Apple's Privacy Policy.

Android Auto™



- YOU EXPRESSLY ACKNOWLEDGE AND AGREE THAT USE OF ANDROID AUTO™ (“THE APPLICATION”) IS AT YOUR SOLE RISK AND THAT THE ENTIRE RISK AS TO SATISFACTORY QUALITY, PERFORMANCE, ACCURACY AND EFFORT IS WITH YOU TO THE MAXIMUM EXTENT PERMITTED BY APPLICABLE LAW, AND THAT THE APPLICATION AND INFORMATION ON THE APPLICATION IS PROVIDED “AS IS” AND “AS AVAILABLE,” WITH ALL FAULTS AND WITHOUT WARRANTY OF ANY KIND, AND MAZDA HEREBY DISCLAIMS ALL WARRANTIES AND CONDITIONS WITH RESPECT TO THE APPLICATION AND INFORMATION ON THE APPLICATION, EITHER EXPRESS, IMPLIED OR STATUTORY, INCLUDING, BUT NOT LIMITED TO, THE IMPLIED WARRANTIES AND/OR CONDITIONS OF MERCHANTABILITY, SATISFACTORY QUALITY, FITNESS FOR A PARTICULAR PURPOSE, ACCURACY, QUIET ENJOYMENT, AND NONINFRINGEMENT OF THIRD PARTY RIGHTS.

AS EXAMPLES, AND WITHOUT LIMITATION, MAZDA DISCLAIMS ANY WARRANTY REGARDING THE ACCURACY OF DATA PROVIDED BY THE APPLICATION, SUCH AS THE ACCURACY OF DIRECTIONS, ESTIMATED TRAVEL TIME, SPEED LIMITS, ROAD CONDITIONS, NEWS, WEATHER, TRAFFIC, OR OTHER CONTENT PROVIDED BY GOOGLE, ITS AFFILIATES, OR THIRD PARTY PROVIDERS; MAZDA DOES NOT GUARANTEE AGAINST LOSS OF APPLICATION DATA, WHICH MAY BE LOST AT ANY TIME; MAZDA DOES NOT GUARANTEE THAT THE APPLICATION OR ANY SERVICES PROVIDED THROUGH THEM WILL BE PROVIDED AT ALL TIMES OR THAT ANY OR ALL SERVICES WILL BE AVAILABLE AT ANY PARTICULAR TIME OR LOCATION. FOR EXAMPLE, SERVICES MAY BE SUSPENDED OR INTERRUPTED WITHOUT NOTICE FOR REPAIR, MAINTENANCE, SECURITY FIXES, UPDATES, ETC., SERVICES MAY BE UNAVAILABLE IN YOUR AREA OR LOCATION, ETC.

IN ADDITION, YOU UNDERSTAND THAT CHANGES IN THIRD PARTY TECHNOLOGY OR GOVERNMENT REGULATION MAY RENDER THE SERVICES AND/OR APPLICATIONS OBSOLETE AND/OR UNUSABLE. TO THE EXTENT NOT PROHIBITED BY LAW, IN NO EVENT SHALL MAZDA OR ITS AFFILIATES BE LIABLE FOR PERSONAL INJURY, OR ANY INCIDENTAL, SPECIAL, INDIRECT OR CONSEQUENTIAL DAMAGES WHATSOEVER, INCLUDING, WITHOUT LIMITATION, DAMAGES FOR LOSS OF PROFITS, CORRUPTION OR LOSS OF DATA, FAILURE TO TRANSMIT OR RECEIVE ANY DATA, BUSINESS INTERRUPTION OR ANY OTHER COMMERCIAL DAMAGES OR LOSSES, ARISING OUT OF OR RELATED TO THE APPLICATION OR YOUR USE OF OR INABILITY TO USE THE APPLICATION OR INFORMATION ON THE APPLICATION.

- When using Android Auto™, please avoid distraction and use Android Auto™ responsibly.

Stay fully aware of driving conditions and always obey applicable laws.

NOTE

- Android Auto™ is provided by Google and its use is subject to your agreement to the Android Auto™ terms of use.
- When using Android Auto™, location, speed, and other vehicle data is transferred to your smart phone. For further details, refer to Google Privacy Policy.

Trademark

- iPhone, iPod touch, iPod nano, Siri and Lightning are trademarks of Apple Inc., registered in the U.S. and other countries.
- Apple CarPlay is a trademark of Apple Inc.
- Use of the Apple CarPlay logo means that a vehicle user interface meets Apple performance standards. Apple is not responsible for the operation of this vehicle or its compliance with safety and regulatory standards. Please note that the use of this product with iPhone, iPod may affect wireless performance.
- iOS is a trademark or registered trademark of Cisco in the U.S. and other countries and is used under license.

- “Made for iPhone” and “Made for iPod” mean that an accessory has been designed to connect specifically to iPhone or iPod, and has been certified by the developer to meet Apple performance standards. Apple is not responsible for the operation of this device or its compliance with safety and regulatory standards. Please note that the use of this accessory with iPhone or iPod may affect wireless performance.
The following models differ depending on the vehicle model and date of manufacture.

Made for
iPhone 11 Pro Max
iPhone 11 Pro
iPhone 11
iPhone XS Max
iPhone XS
iPhone XR
iPhone X
iPhone 8 Plus
iPhone 8
iPhone 7 Plus
iPhone 7
iPhone SE
iPhone 6s Plus
iPhone 6s
iPhone 6 Plus
iPhone 6
iPhone 5s
iPod touch (7th Generation)
iPod touch (6th Generation)



- Google, Android, Android Auto and other related marks are trademarks of Google LLC.
- AudioPilot is a registered trademark of Bose Corporation.
- Centerpoint is a registered trademark of Bose Corporation.
- This product is protected by certain intellectual property rights of Microsoft. Use or distribution of such technology outside of this product is prohibited without a license from Microsoft.

- This product is licensed under the MPEG-4 patent portfolio license, AVC patent portfolio license and VC-1 patent portfolio license for the personal use of a consumer or other uses in which it does not receive remuneration to (i) encode video in compliance with the MPEG-4 Visual Standard, AVC Standard and VC-1 Standard (“MPEG-4/AVC/VC-1 Video”) and (ii) decode MPEG-4/AVC/VC-1 Video that was encoded by a consumer engaged in a personal activity and/or was obtained from a video provider licensed to provide MPEG-4/AVC/VC-1 Video. No license is granted or shall be implied for any other use. Additional information may be obtained from MPEG LA, L.L.C. See <http://www.mpegla.com>.
- The Bluetooth® word mark and logos are registered trademarks owned by Bluetooth SIG, Inc. and any use of such marks by Panasonic Corporation is under license. Other trademarks and trade names are those of their respective owners.



- SDHC Logo is a trademark of SD-3C, LLC.



- Gracenote, the Gracenote logo and logotype, “Powered by Gracenote” and Gracenote MusicID are either registered trademarks or trademarks of Gracenote, Inc. in the United States and/or other countries.



Emergency Call System

Emergency Call System

When an emergency situation such as an accident or sudden illness occurs, the Emergency call system dials the call centre automatically or the user can make a call to the call centre manually to enable a voice call.

The system operates automatically when the vehicle receives an impact of a certain level or more in a collision, or it can be operated manually using the Emergency call switch if an emergency situation arises such as sudden illness.

The call centre operator confirms the status via the voice call, confirms the vehicle's position information using the GNSS*1, and calls the police or emergency services.

*1 GNSS, short for "Global Navigation Satellite System", is a system that obtains the vehicle's current location by receiving radio waves emitted from the GNSS satellites to the ground.

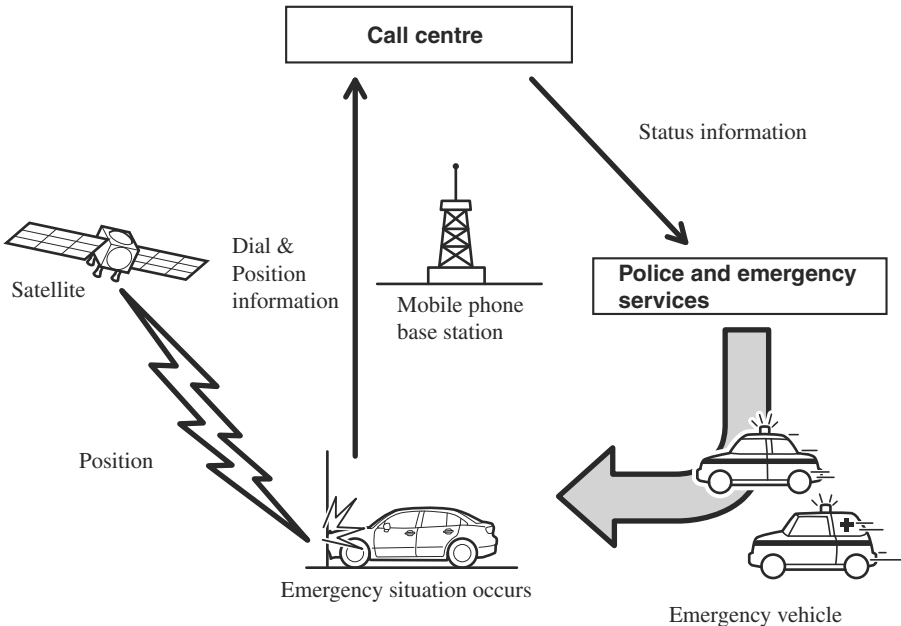

Component Parts of Mazda eCall

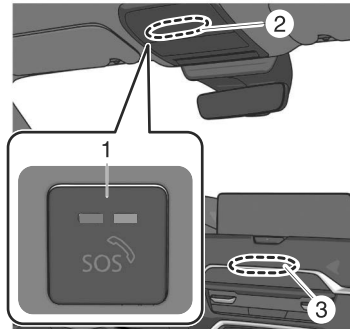

1. Emergency call switch
2. Microphone, Speaker
3. Aerial

Handling of Data in Accordance with Laws and Regulations (except UAE)

DESCRIPTION OF THE Emergency call system IN-VEHICLE SYSTEM

- The 112-based Emergency call system service is a public service of general interest and is accessible free of charge.
- The 112-based Emergency call system in-vehicle system is activated by default. It is activated automatically by means of in-vehicle sensors in the event of a severe accident.
- The 112-based Emergency call system in-vehicle system can also be triggered manually.
- In the event of a critical system failure that would disable the 112-based Emergency call system in-vehicle system, the following warning will be given to the occupants of the vehicle:
- If a problem occurs with the Emergency call system, the indicator light on the Emergency call switch turns on in red and a beep sound is activated 3 times. Thereafter, if the indicator light remains turned on in red, the system will not operate normally in an emergency. Have the vehicle inspected at an expert repairer (we recommend an Authorised Mazda Repairer) as soon as possible.

INFORMATION ON DATA PROCESSING

- Any processing of personal data through the 112-based Emergency call system in-vehicle system shall comply with the personal data protection rules provided for in Directives 95/46/EC(1) and 2002/58/EC(2) of the European Parliament and of the Council, and in particular, shall be based on the necessity to protect the vital interests of the individuals in accordance with Article 7(d) of Directive 95/46/EC(3).
- Processing of such data is strictly limited to the purpose of handling the Emergency call system to the single European emergency number 112.

Types of data and its recipients

- The 112-based Emergency call system in-vehicle system may collect and process only the following data:
- Vehicle Identification Number
- Vehicle type (passenger vehicle or light commercial vehicle)
- Vehicle propulsion storage type (petrol/diesel/CNG/LPG/electric/hydrogen/hybrid electric)
- Vehicle last three locations and direction of travel
- Log file of the automatic activation of the system and its timestamp
- Recipients of data processed by the 112-based Emergency call system in-vehicle system are the relevant public safety answering points designated by the respective public authorities of the country on which territory they are located, to first receive and handle emergency calls (Emergency call system) to the single European emergency number 112.

Arrangements for data processing

- The 112-based Emergency call system in-vehicle system is designed in such a way as to ensure that the data contained in the system memory is not available outside the system before an Emergency call system is triggered.
- The 112-based Emergency call system in-vehicle system is designed in such a way as to ensure that it is not traceable and not subject to any constant tracking in its normal operation status.
- The 112-based Emergency call system in-vehicle system is designed in such a way as to ensure that data in the system internal memory is automatically and continuously removed.
- The vehicle location data is constantly overwritten in the internal memory of the system so as always to keep maximum of the last three up-to-date locations of the vehicle necessary for the normal functioning of the system.
- The log of activity data in the 112-based Emergency call system in-vehicle system is kept for no longer than necessary for attaining the purpose of handling the Emergency call system and in any case not beyond 13 hours from the moment an Emergency call system was initiated.

Modalities for exercising data subject's rights

- The data subject (the vehicle's owner) has a right of access to data and as appropriate to request the rectification, erasure or blocking of data, concerning him or her, the processing of which does not comply with the provisions of Directive 95/46/EC. Any third parties to whom the data have been disclosed have to be notified of such rectification, erasure or blocking carried out in compliance with this Directive, unless it proves impossible or involves a disproportionate effort.
- The data subject has a right to complain to the competent data protection authority if he or she considers that his or her rights have been infringed as a result of the processing of his or her personal data.

Contact service responsible for handling access requests:

Please contact your local Mazda Organisation for data protection requests. Contact details related thereto are listed in the Privacy Statement which you find on your country-specific webpage.

Please visit "<https://www.mazda.eu>" to find your country-specific webpage.

Warnings and Cautions for Using the Emergency Call System

WARNING

When using the emergency call system, keep medical devices such as an implanted heart pacemaker or defibrillator about 22 cm (8.7 in) or more away from the vehicle's aerial. Otherwise, the operation of the medical device may be affected by radio waves.

CAUTION

- Do not disassemble the Emergency call system. Otherwise, it could become damaged and may not function in an emergency.
- The Emergency call system has a special built-in battery so that it can operate even if the power supply from the vehicle is cut such as in an accident. Heed the following cautions. If the Emergency call system is not used correctly it may not operate.

- If the built-in battery power is low due to natural discharge and the system determines that there is a problem, the Emergency call system cannot be used. If the system determines that there is a problem, the indicator light (red) in the Emergency call switch turns on to notify the driver. Have the vehicle inspected at an expert repairer (we recommend an Authorised Mazda Repairer). Refer to Indicator light/Beep sound in How to Use the Emergency Call System on page 7-30.

NOTE

- The Emergency call system can be used when the vehicle power is switched ON.
- There are two ways the Emergency call system makes calls; automatically or manually.
- The Emergency call system may not make a connection under the following conditions or depending on the use environment. If the Emergency call system does not connect, make a call from another telephone such as the nearest available public telephone.
 - The vehicle is outside of a mobile phone network area
 - The vehicle is in a weak radio wave transmission environment (such as inside tunnels, underground parking areas, shadow of buildings, and mountain areas)
 - The vehicle does not receive an impact of a certain level or more even if an accident has occurred.
 - An extremely serious collision occurs resulting in damage to the Emergency call system.

- The position information cannot be obtained when signals cannot be received from the GNSS satellites, however, voice calls are possible.
- When a voice call is made by the Emergency call system, the audio system is muted so that it does not interfere with the call.
- It may take some time for the call centre to respond after the Emergency call system first starts operating.
- If you are unable to respond to an operator's questions after the voice call begins, the operator may proceed with emergency procedures at their own discretion.
- Even if it is difficult for you to hear the operator's voice, your voice may be heard by the call centre. Continue explaining your circumstances.
- If the Emergency call system operates while you are making a call with your mobile phone using Bluetooth® Hands-Free, the call may be interrupted.
- It may not be possible to receive a call using the Bluetooth® Hands-Free normally while the Emergency call system is operating.
- A voice call with an operator may not be possible if the speaker or microphone is broken. If the speaker or microphone is broken, always have the vehicle inspected at an expert repairer (we recommend an Authorised Mazda Repairer).
- The Emergency call system may not operate normally outside of the following temperature range: If the Emergency call system does not operate normally, make a call from another telephone such as the nearest available public telephone.

- Operation temperature range: —
40 °C (–40 °F) to 85 °C (185 °F)
- There may be a difference between the position information sent to the call centre and the actual position of the vehicle where the call was made. Indicate landmarks around the position of the vehicle where the call is being made to the operator during the voice call.

How to Use the Emergency Call System

Flow of Emergency call system

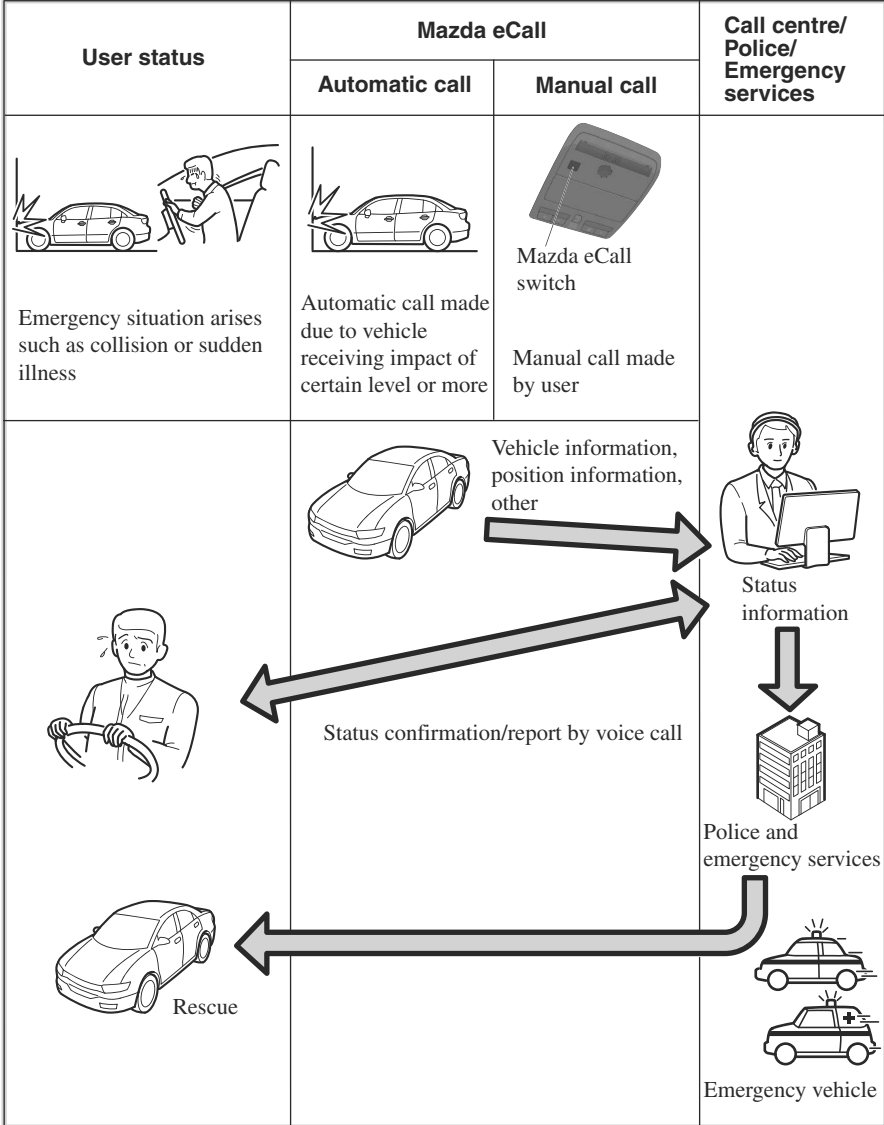

Automatic emergency calls

If the vehicle receives an impact of a certain level or more in a collision, vehicle information is automatically sent to the call centre.

When the transmission of the vehicle information is completed or about 20 seconds have elapsed since the transmission began, the voice call with the call centre starts.



If an automatic call is made, the built-in battery power may be depleted and emergency calls may not be possible in the event that an emergency occurs again. After an automatic emergency call has been made, have the built-in battery replaced by an expert repairer (we recommend an Authorised Mazda Repairer).

NOTE

- Automatic emergency calls cannot be cancelled by the user.
 - The call centre will end an emergency call. The user cannot end the emergency call.
 - If the vehicle receives an impact of a certain level or more in a collision, an automatic call is made even if the air bags do not deploy.
 - If a call is disconnected or a call cannot be made to the call centre correctly, an automatic call is made again to the call centre. Redialing cannot be cancelled.
1. If the vehicle receives an impact of a certain level or more in a collision, the Emergency call system begins operating automatically.
 2. The indicator light (green) on the Emergency call switch flashes slowly (0.5 second intervals) and the call is made to the call centre.

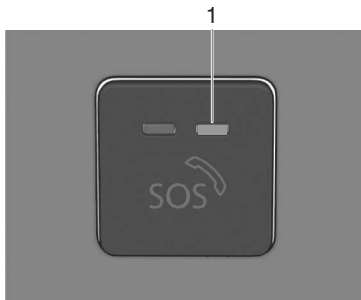

1. Green
3. When the connection is established with the call centre, the indicator light (green) flashes somewhat quickly (0.3 second intervals) and the transmission of the vehicle information begins.
4. When the transmission of the vehicle information is completed or about 20 seconds have elapsed since the transmission began, the beep sounds and the voice call with the call centre starts.

Emergency Call System

5. If the connection fails, the indicator light (red) turns on and the indicator light (green) flashes quickly (0.15 second intervals) and the beep sounds simultaneously.

In this case, make a manual connection using the Emergency call switch because an automatic connection is not possible.

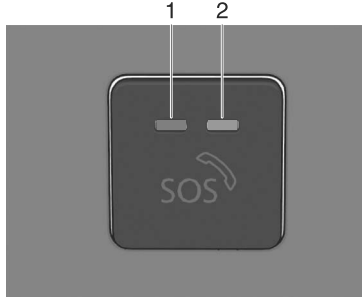

1. Red (Turns on)
2. Green (Flashes)

Manual emergency calls

With the vehicle power switched ON, long-press the Emergency call switch and after releasing your finger from the switch, the vehicle information is automatically transmitted to the call centre.

When the transmission of the vehicle information is completed or about 20 seconds have elapsed since the transmission began, the voice call with the call centre starts.

NOTE

- Only make calls manually for conditions requiring urgent treatment such as illness or serious injury.
- When making emergency calls manually, stop the vehicle in a safe location before making the call.
- The call centre will end an emergency call. The user cannot end the emergency call.
- If a call is disconnected or a call cannot be made to the call centre correctly, an automatic call is made again to the call centre.

1. Make sure that the vehicle power is switched ON.

2. Long-press the Emergency call switch on the overhead console and then release your finger from the switch.

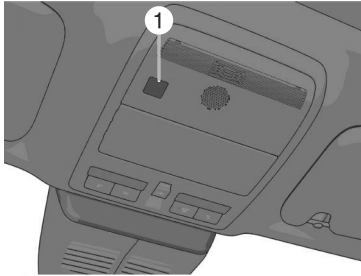

1. Emergency call switch
3. The indicator light (green) on the Emergency call switch flashes slowly (0.5 second intervals) and the call is made to the call centre.

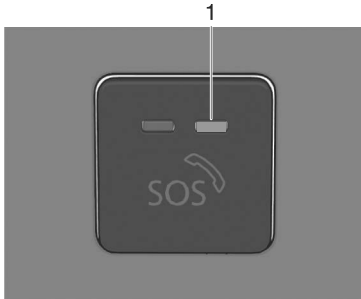

1. Green
4. When the connection is established with the call centre, the indicator light (green) flashes somewhat quickly (0.3 second intervals) and the transmission of the vehicle information begins.
5. When the transmission of the vehicle information is completed or about 20 seconds have elapsed since the transmission began, the beep sounds and the voice call with the call centre starts.
6. If the connection fails, the indicator light (red) turns on and the indicator light (green) flashes quickly (0.15 second intervals), and the beep sounds simultaneously.

Emergency Call System

Make a manual emergency call again.

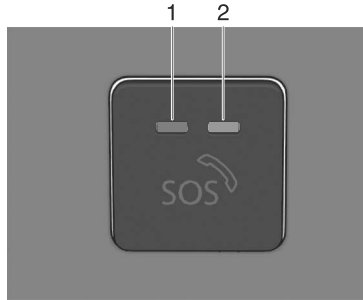

1. Red (Turns on)
2. Green (Flashes)

NOTE

If a call to the call centre does not connect even though the indicator light shows a call is possible, make a call to the police or other authority by means other than the Emergency call system.

Indicator light/Beep sound

The indicator light turns on/flashes and beep sounds are activated to notify the driver of the system operation status or if there is a problem with the system.

Status	Indicator light			Beep sound status	On/flashing conditions
	Green	Red	Flash interval		
Diagnosis	Turns on	Turns on	—	—	When the vehicle power is switched ON, it turns on and then turns off after a few seconds. NOTE A manual emergency call is not possible during diagnosis.
Normal	Turns off	Turns off	—	—	The system is operating normally.

Status	Indicator light			Beep sound status	On/flashing conditions
	Green	Red	Flash interval		
Malfunction	Turns off	Turns on	—	3 beeps (Slow intermittent sound)	<ul style="list-style-type: none"> • A system malfunction is detected. • The remaining power of the built-in battery is low. <div style="border: 1px solid black; padding: 5px; display: inline-block; margin: 10px 0;">  CAUTION </div> <p>If the indicator light (red) remains on constantly, the system will not operate normally. Have the vehicle inspected at an expert repairer (we recommend an Authorised Mazda Repairer) as soon as possible.</p>
Call being made with call centre	Flashes	Turns off	Slow (0.5 second intervals)	The beep does not sound, but the ringback tone can be heard.	An emergency call is being made by the Emergency call system.
Vehicle information is being transmitted	Flashes	Turns off	Somewhat quick (0.3 second intervals)	—	Vehicle information is being transmitted to the call centre.
Start of voice call	Turns on	Turns off	—	1 beep	During a voice call with the call centre.
During voice call	Turns on	Turns off	—	—	
Connection failure	Flashes	Turns on	Quick (0.15 second intervals)	3 beeps (Fast intermittent sound)	When an emergency call fails to connect.
Waiting for callback from call centre	Flashes	Turns on	Very slow (1 second intervals)	—	When waiting for the call centre to call back. (Flashes for about 1 hour after 30 seconds have passed since the call with the call centre was ended.)

Mazda ERA-GLONASS

When an emergency situation such as an accident or sudden illness occurs, the Mazda ERA-GLONASS dials the call centre automatically or the user can make a call to the call centre manually to enable a voice call.

The system operates automatically when the vehicle receives an impact of a certain level or more in a collision, or it can be operated manually using the Emergency call switch if an emergency situation arises such as sudden illness.

The call centre operator confirms the status via the voice call, confirms the vehicle's position information using the GNSS*1, and calls the police or emergency services.

*1 GNSS, short for "Global Navigation Satellite System", is a system that obtains the vehicle's current location by receiving radio waves emitted from the GNSS satellites to the ground.

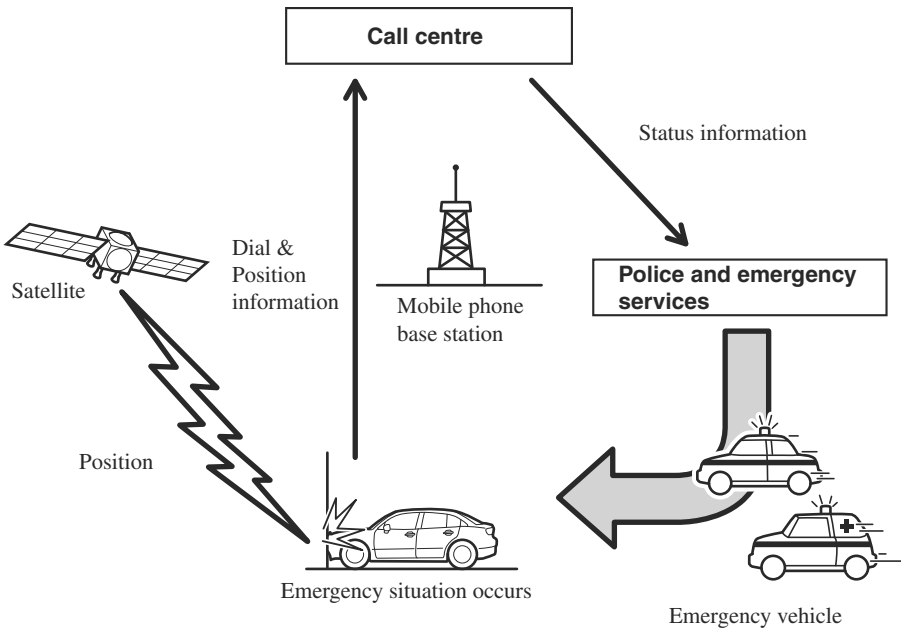

Component Parts of Mazda eCall

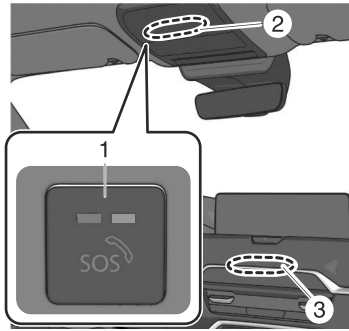

1. Emergency call switch
2. Microphone, Speaker
3. Aerial

Warnings and Cautions for Using Mazda ERA-GLONASS

WARNING

When using the Mazda ERA-GLONASS, keep medical devices such as an implanted heart pacemaker or defibrillator about 22 cm (8.7 in) or more away from the vehicle's aerial.

Otherwise, the operation of the medical device may be affected by radio waves.

CAUTION

- Do not disassemble the Mazda ERA-GLONASS. Otherwise, it could become damaged and may not function in an emergency.
- The Mazda ERA-GLONASS has a special built-in battery so that it can operate even if the power supply from the vehicle is cut such as in an accident.
Heed the following cautions. If the Mazda ERA-GLONASS is not used correctly it may not operate.
 - The built-in battery is not a rechargeable type battery. Do not attempt to recharge the battery.
 - The built-in battery life is 3 years. Have the built-in battery replaced at an expert repairer (we recommend an Authorised Mazda Repairer) periodically.

- If the built-in battery power is low due to natural discharge and the system determines that there is a problem, the Mazda ERA-GLONASS cannot be used. If the system determines that there is a problem, the indicator light (red) in the Emergency call switch turns on to notify the driver. Have the vehicle inspected at an expert repairer (we recommend an Authorised Mazda Repairer). Refer to Indicator light/Beep sound in How to Use Mazda ERA-GLONASS on page 7-40.

NOTE

- The Mazda ERA-GLONASS can be used when the ignition is switched ON.
- There are two ways the Mazda ERA-GLONASS makes calls; automatically or manually.
- The Mazda ERA-GLONASS may not make a connection under the following conditions or depending on the use environment. If the Mazda ERA-GLONASS does not connect, make a call from another telephone such as the nearest available public telephone.
 - The vehicle is outside of a mobile phone network area
 - The vehicle is in a weak radio wave transmission environment (such as inside tunnels, underground parking areas, shadow of buildings, and mountain areas)
 - The vehicle does not receive an impact of a certain level or more even if an accident has occurred.
 - An extremely serious collision occurs resulting in damage to the Mazda ERA-GLONASS.

- The position information cannot be obtained when signals cannot be received from the GNSS satellites, however, voice calls are possible.
 - When a voice call is made by the Mazda ERA-GLONASS, the audio system is muted so that it does not interfere with the call.
 - It may take some time for the call centre to respond after the Mazda ERA-GLONASS first starts operating.
 - If you are unable to respond to an operator's questions after the voice call begins, the operator may proceed with emergency procedures at their own discretion.
 - Even if it is difficult for you to hear the operator's voice, your voice may be heard by the call centre. Continue explaining your circumstances.
 - If the Mazda ERA-GLONASS operates while you are making a call with your mobile phone using Bluetooth® Hands-Free, the call may be interrupted.
 - It may not be possible to receive a call using the Bluetooth® Hands-Free normally while the Mazda ERA-GLONASS is operating.
 - A voice call with an operator may not be possible if the speaker or microphone is broken. If the speaker or microphone is broken, always have the vehicle inspected at an expert repairer (we recommend an Authorised Mazda Repairer).
 - The Mazda ERA-GLONASS may not operate normally outside of the following temperature range: If the Mazda ERA-GLONASS does not operate normally, make a call from another telephone such as the nearest available public telephone. Operation temperature range: — 40 °C (–40 °F) to 85 °C (185 °F)
- There may be a difference between the position information sent to the call centre and the actual position of the vehicle where the call was made. Indicate landmarks around the position of the vehicle where the call is being made to the operator during the voice call.

How to Use Mazda ERA-GLONASS

Flow of Mazda ERA-GLONASS

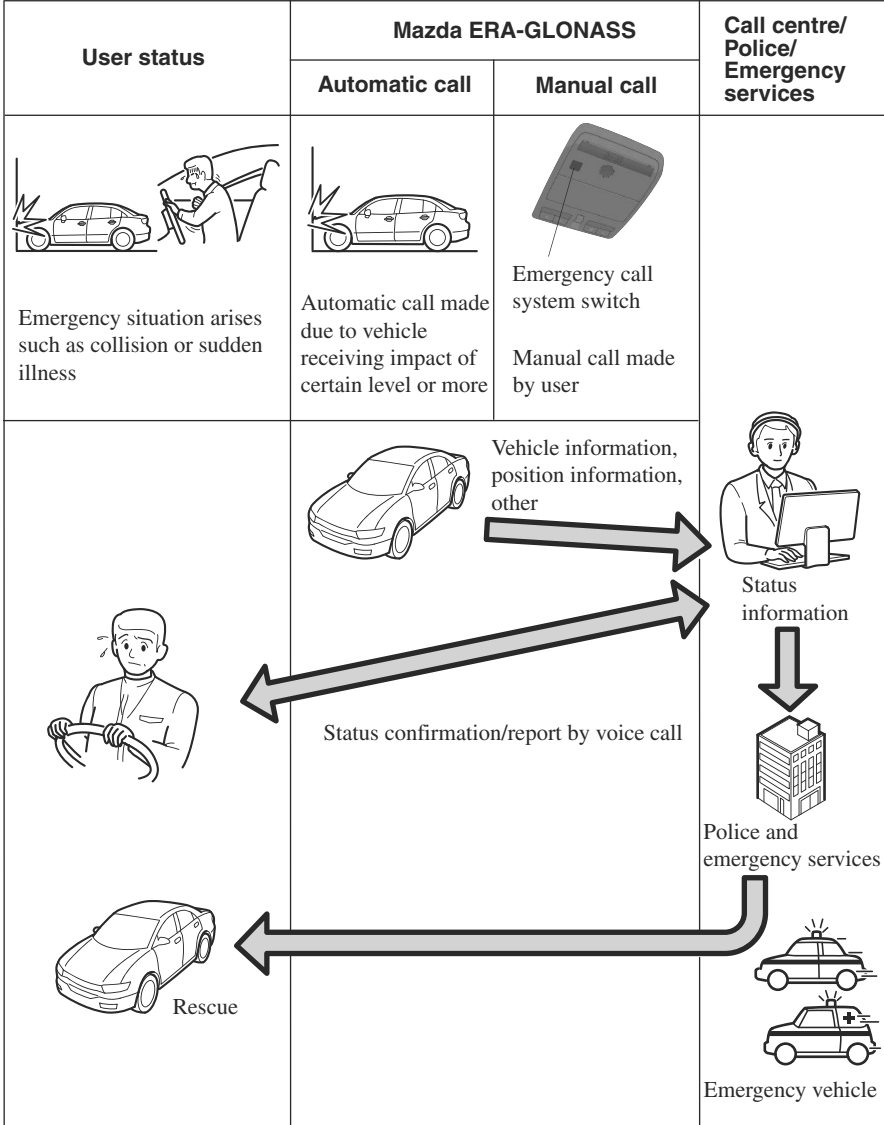

Automatic emergency calls

If the vehicle receives an impact of a certain level or more in a collision, vehicle information is automatically sent to the call centre.

When the transmission of the vehicle information is completed or about 20 seconds have elapsed since the transmission began, the voice call with the call centre starts.



If an automatic call is made, the built-in battery power may be depleted and emergency calls may not be possible in the event that an emergency occurs again. After an automatic emergency call has been made, have the built-in battery replaced by an expert repairer (we recommend an Authorised Mazda Repairer).

NOTE

- Automatic emergency calls cannot be cancelled by the user.
 - The call centre will end an emergency call. The user cannot end the emergency call.
 - If the vehicle receives an impact of a certain level or more in a collision, an automatic call is made even if the air bags do not deploy.
 - If a call is disconnected or a call cannot be made to the call centre correctly, an automatic call is made again to the call centre. Redialing cannot be cancelled.
1. If the vehicle receives an impact of a certain level or more in a collision, the Mazda ERA-GLONASS begins operating automatically.
 2. The indicator light (green) on the Emergency call switch flashes slowly (0.5 second intervals) and the call is made to the call centre.

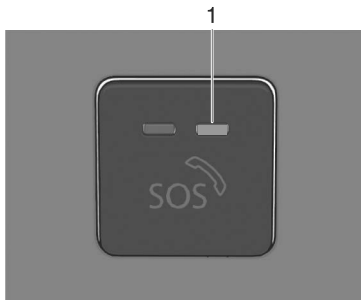

1. Green
3. When the connection is established with the call centre, the indicator light (green) flashes somewhat quickly (0.3 second intervals) and the beep sounds simultaneously, and the transmission of the vehicle information begins.
4. When the transmission of the vehicle information is completed or about 20 seconds have elapsed since the transmission began, the beep sounds and the voice call with the call centre starts.

5. If the connection fails, the indicator light (red) turns on and the indicator light (green) flashes quickly (0.15 second intervals) and the beep sounds simultaneously.

In this case, make a manual connection using the Emergency call switch because an automatic connection is not possible.

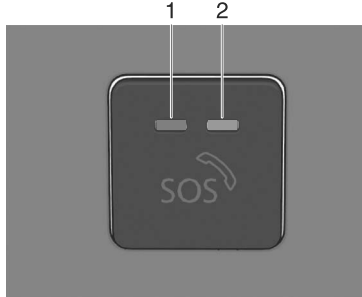

1. Red (Turns on)
2. Green (Flashes)

Manual emergency calls

With the ignition switched ON, long-press the Emergency call switch and after releasing your finger from the switch, the vehicle information is automatically transmitted to the call centre.

When the transmission of the vehicle information is completed or about 20 seconds have elapsed since the transmission began, the voice call with the call centre starts.

NOTE

- Only make calls manually for conditions requiring urgent treatment such as illness or serious injury.
- When making emergency calls manually, stop the vehicle in a safe location before making the call.
- The call centre will end an emergency call. The user cannot end the emergency call.
- If a call is disconnected or a call cannot be made to the call centre correctly, an automatic call is made again to the call centre. To cancel the redialing, refer to Manual emergency call cancellation.

1. Make sure that the ignition is switched ON.

2. Long-press the Emergency call switch on the overhead console and then release your finger from the switch.

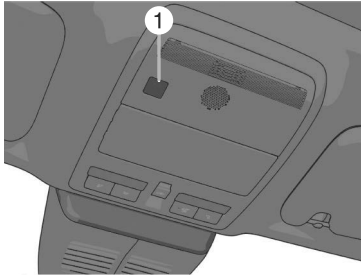

1. Emergency call switch
3. The indicator light (green) on the Emergency call switch flashes slowly (0.5 second intervals) and the call is made to the call centre.

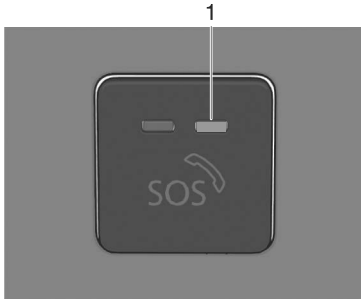

1. Green
4. When the connection is established with the call centre, the indicator light (green) flashes somewhat quickly (0.3 second intervals) and the beep sounds simultaneously, and the transmission of the vehicle information begins.
5. When the transmission of the vehicle information is completed or about 20 seconds have elapsed since the transmission began, the beep sounds and the voice call with the call centre starts.
6. If the connection fails, the indicator light (red) turns on and the indicator light (green) flashes quickly (0.15 second intervals), and the beep sounds simultaneously.

Make a manual emergency call again.

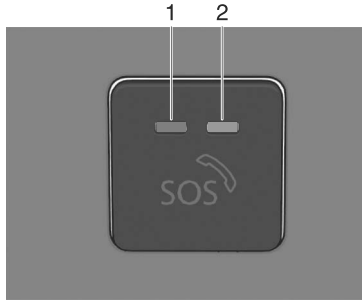

1. Red (Turns on)
2. Green (Flashes)

NOTE

If a call to the call centre does not connect even though the indicator light shows a call is possible, make a call to the police or other authority by means other than the Mazda ERA-GLONASS.

Manual emergency call cancellation

A manual emergency call can be cancelled even after the Emergency call switch has been pressed by pressing the switch again, as long as the call with the call centre has not begun. If the call cannot be cancelled and the call with the call centre has begun, tell the operator that the call is mistaken.

Indicator light/Beep sound

The indicator light turns on/flashes and beep sounds are activated to notify the driver of the system operation status or if there is a problem with the system.

Status	Indicator light			Beep sound status	On/flashing conditions
	Green	Red	Flash interval		
Diagnosis	Turns on	Turns on	—	—	When the ignition is switched ON, it turns on and then turns off after a few seconds. NOTE A manual emergency call is not possible during diagnosis.
Normal	Turns off	Turns off	—	—	The system is operating normally.

Status	Indicator light			Beep sound status	On/flashing conditions
	Green	Red	Flash interval		
Malfunction	Turns off	Turns on	—	3 beeps (Slow intermittent sound)	<ul style="list-style-type: none"> • A system malfunction is detected. • The remaining power of the built-in battery is low. <div style="border: 1px solid black; padding: 5px; display: inline-block; margin: 10px 0;">  CAUTION </div> <p>If the indicator light (red) remains on constantly, the system will not operate normally. Have the vehicle inspected at an expert repairer (we recommend an Authorised Mazda Repairer) as soon as possible.</p>
Call being made with call centre	Flashes	Turns off	Slow (0.5 second intervals)	The beep does not sound, but the ringback tone can be heard.	An emergency call is being made by the Mazda ERA-GLONASS.
Vehicle information is being transmitted	Flashes	Turns off	Somewhat quick (0.3 second intervals)	Continuous intermittent sound	Vehicle information is being transmitted to the call centre.
Start of voice call	Turns on	Turns off	—	1 beep	During a voice call with the call centre.
During voice call	Turns on	Turns off	—	—	
Connection failure	Flashes	Turns on	Quick (0.15 second intervals)	3 beeps (Fast intermittent sound)	When an emergency call fails to connect.

Test Mode

The test mode function makes sure that the Mazda ERA-GLONASS can operate normally.

Have your vehicle tested at an expert repairer (we recommend an Authorised Mazda Repairer) when performing the test mode.

Method to start test mode

Switch the ignition ON while the parking brake is applied, and wait 2 minutes with the vehicle stopped.

After that, perform the following procedure.

Turn on the hazard warning lights.



Within 5 seconds

Move the signal lever up to right turn

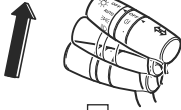

Within 1 second

Return the signal lever to off

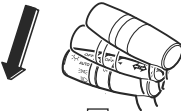

Within 1 second

Move the signal lever up to right turn

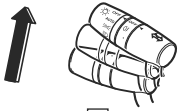

Within 1 second

Return the signal lever to off

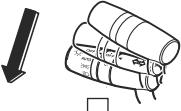

Within 1 second

Move the signal lever up to right turn

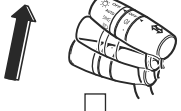

Within 1 second
Return the signal lever to off

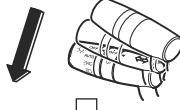

Within 1 second
Move the signal lever down to left turn

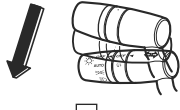

Within 1 second
Return the signal lever to off

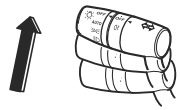

Within 1 second
Move the signal lever down to left turn

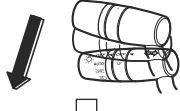

Within 1 second
Return the signal lever to off

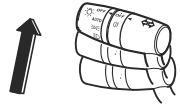

Within 5 seconds

Turn off the hazard warning lights.



Both red and green
Emergency call
indicator lights turn on.



Within 5 seconds

Press the Emergency call
switch for one second or
longer and release it.

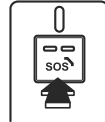

After the procedure is completed, the test mode is performed in the following order automatically.

1. Procedure is completed
2. Switch to test mode
3. Call is placed to call centre
4. Vehicle information is sent
5. Start of voice call
6. Voice guidance from the call centre is played

NOTE

Communication with the call centre may fail if the reception is poor. Perform the test mode in a location with good reception.

The test mode finishes automatically.

Warning and Cautions for Using the Storage Compartments

WARNING

When loading cargo, make sure that it is completely secured.

If the cargo is not completely secured, it may move or collapse while driving or during sudden braking, resulting in injury or an accident.

CAUTION

- Always close the covers for storage such as the glove compartment when the vehicle is being driven. Open storage boxes and their contents may cause injury during sudden braking or if the vehicle is involved in a collision.
- Be careful when storing items in uncovered storage spaces. If an item is ejected from the storage space during sudden braking, manoeuvring, or acceleration it could lead to an accident.
- Do not leave lighters or eyeglasses in the storage boxes while parked under the sun. A lighter could explode or the plastic material in eyeglasses could deform and crack from high temperature.

Warnings and Cautions for Using the Cup Holders

WARNING

Never use a cup holder to hold hot liquids while the vehicle is moving. Using a cup holder to hold hot liquids while the vehicle is moving is dangerous. If the contents spill, you could be scalded.

Do not put anything other than cups or drink cans in cup holders.

Putting objects other than cups or drink cans in a cup holder is dangerous.

During sudden braking or manoeuvring, occupants could be hit and injured, or objects could be thrown around the vehicle, causing interference with the driver and the possibility of an accident. Only use a cup holder for cups or drink cans.

Cup Holders

Cup holders are installed to the following positions.

Front

Type A

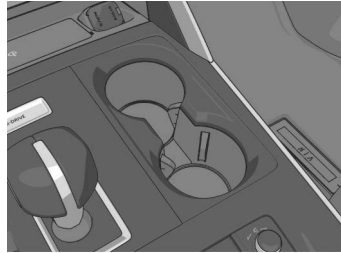

Type B

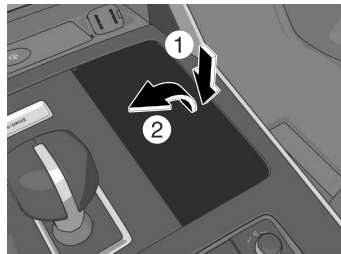

Rear

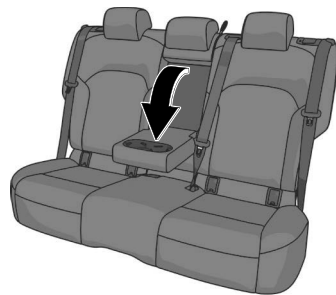

Bottle Holder

Warnings and Cautions for Using the Bottle Holder

! CAUTION

Do not use the bottle holders for containers without caps. The contents may spill when opening/closing the door or while driving the vehicle.

Bottle Holder

Plastic bottles can be placed in the bottle holders.

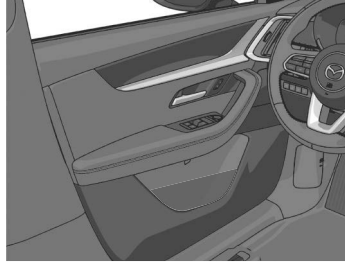

How to Use the Glove Compartment

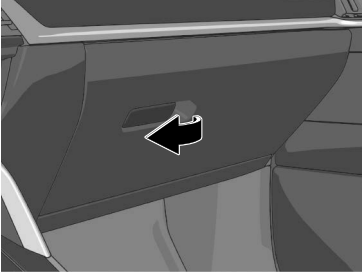

How to Use the Coin Box*

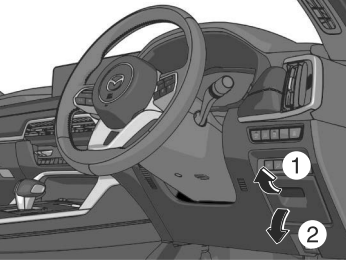

How to Use the Centre Console

Open

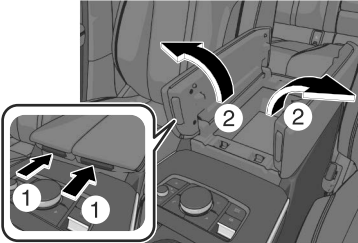

Close



Overhead Console

How to Use the Overhead Console*

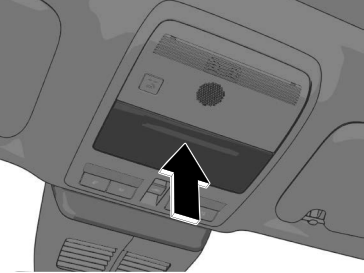

Warning and Cautions for Using the Rear Coat Hooks

WARNING

Never hang heavy or sharp objects on the assist grips and coat hooks. Hanging heavy or sharp-ended objects such as a coat hanger from the assist grips or coat hooks is dangerous as they can fly off and hit an occupant in the cabin if a curtain air bag was to deploy, which could result in serious injury or death.

How to Use the Rear Coat Hooks

Use the rear coat hooks when hanging a coat or jacket.

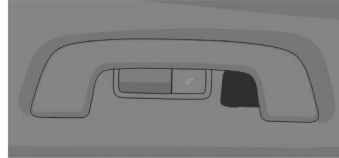

Luggage Compartment

Luggage Compartment

Cargo Securing Loops

Use rope or a net to secure cargo.

Cargo Sub-Compartment

The spaces can be used to store small items.

How to Use the Luggage Compartment

Cargo Securing Loops

The tension load of a luggage hook is 20 kg (44 lb). Do not tighten a rope to the anchors excessively.

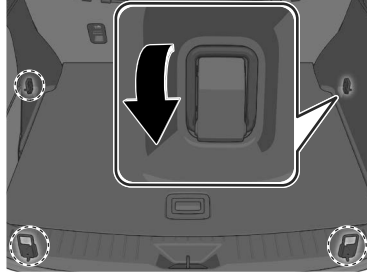

Cargo Sub-Compartment*

Open the luggage board.

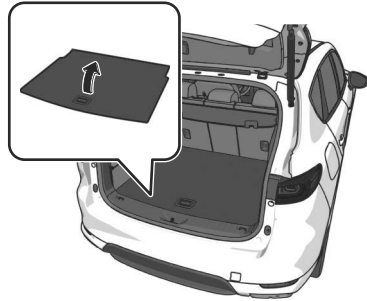

NOTE

Lowering the divider net* provides a larger storage space for wider use.

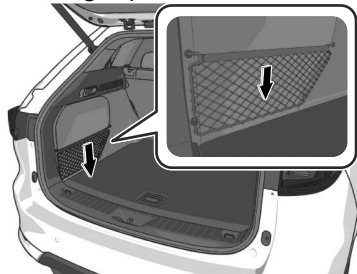

How to Use the Sunvisor

When blocking light from the front

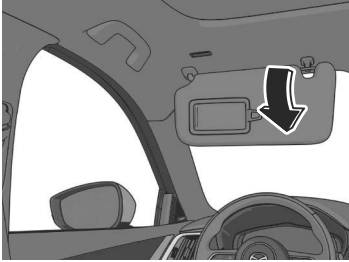

When blocking light from the side

Unhook the sunvisor and swing it to the side.

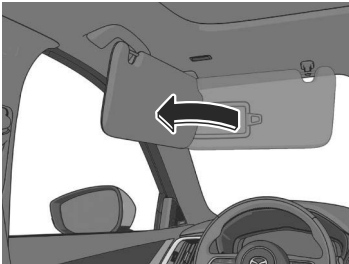

How to Use the Vanity Mirrors

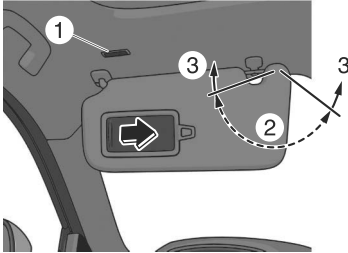

1. Vanity mirror light*
2. Lighting range
3. Off range

For vehicles with a light, it turns on when the cover is opened.

The light turns on only when the sunvisor angle is within the lighting range.

NOTE

- If a vanity mirror light is left on with the vehicle power switched OFF, the light is turned off automatically to prevent the lead-acid battery from being discharged.
- The vanity mirror light can be turned on again by doing any of the following operations:
 - Opening/closing any door.
 - Unlocking any door.
 - Switching the vehicle power to ACC or ON.
 - Switching an overhead light/front map light on.

Illuminated Entry System

The interior lights turn on/off in conjunction with the opening/closing of the doors and the position of the vehicle power (ON/OFF).

How to Use the Illuminated Entry System

The overhead lights turn on when any of the following operations is done with the overhead light switch in the DOOR-linked position.

- The driver's door is unlocked with the vehicle power switched OFF.
- The vehicle power is switched OFF with all doors closed.

The overhead lights turns off when any of the following operations is done.

- The driver's door is locked.
- The vehicle power is switched ON.

When the vehicle power is switched OFF and the interior lights remain on, they turn off after a certain period of time has passed.

NOTE

- The amount of time until the illuminated entry system turns off can be changed.
Refer to Mazda Connect Owner's Manual or consult an expert repairer (we recommend an Authorised Mazda Repairer).
- The illuminated entry system does not operate when the overhead lights are turned on by operating the overhead light ON/OFF switch.

Interior Lights

How to Use the Overhead Lights

Front

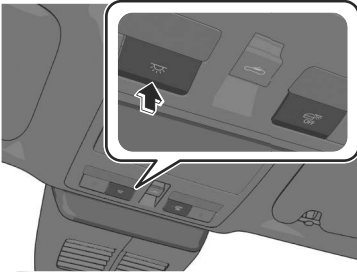

The overhead lights turn on.

Press the  switch again to turn off the overhead lights.

When the door interlock is ON

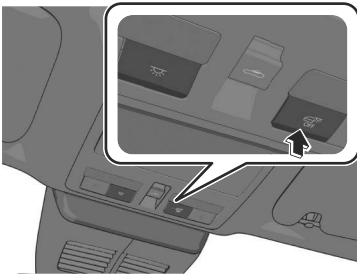

- The indicator light in the  switch turns off.
- The lights turn on when any of the doors is opened.
- The light turns on/off depending on the illumination entry system.

When the door interlock is OFF

The indicator light in the switch turns on.

Rear

The rear overhead lights also turns on/off in conjunction with the operation of the front overhead lights.

Type A

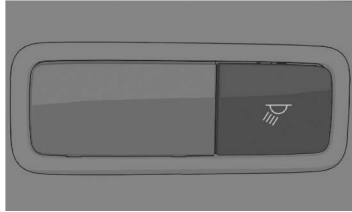

Type B

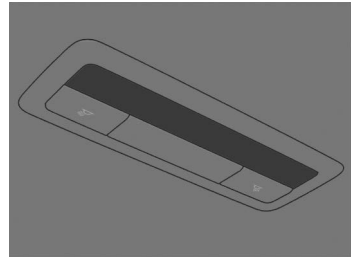

How to Use the Map Lights

Front

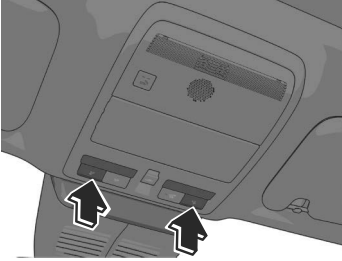

The map light turns on.
Press the switch again to turn off the map lights.

Rear

Type A

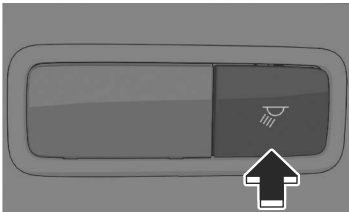

Type B

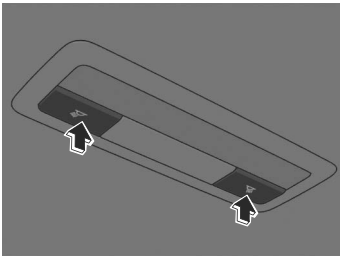

The map light turns on.
Press the switch again to turn off the map lights.

NOTE

- Pressing the switch does not turn the lights off in any of the following cases.
 - When the light is turned on by operating an overhead light  switch.
 - When the illuminated entry system is operating.
- **(Rear)**
Once the rear map lights have been turned off, they will turn on/off in conjunction with the operation of an overhead light switch.

Interior Lights

How to Use the Door Courtesy Lights*

The light turns on when any door is opened and turns off when closed.

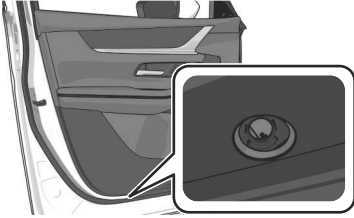

How to Use the Luggage Compartment Lights

Open the liftgate.

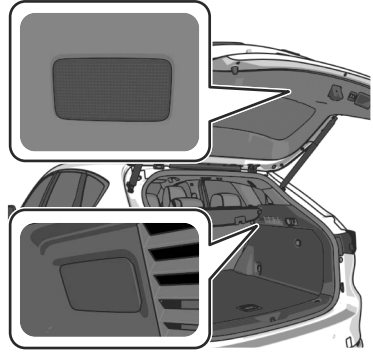

The luggage compartment lights turn on.

When the liftgate is closed, the luggage compartment lights turn off.

How to Use the Ambient Lights*

When the vehicle power is switched ON, the ambient lights remain on. The ambient lights turn on/off in conjunction with the Illuminated Entry System in the cabin and position lights turned on.

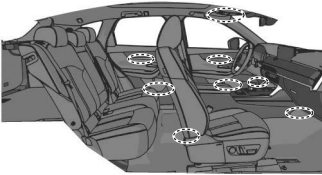

NOTE

- The light turns on/off depending on the illumination entry system when the vehicle power is switched OFF.
- The intensity of the ambient lights can be changed when the position lights are turned on.

For the method of changing the setting, refer to the Mazda Connect owner's manual.

Accessory Sockets

The accessory socket is used as a socket for accessories when the vehicle power is switched to ACC or ON. Only use accessories that have a maximum power consumption of 120 W (DC12V-10A) or below.

Warnings and Cautions When Using the Accessory Socket

CAUTION

- Always close the cover when it is not in use. If foreign matter or liquid penetrates the socket, it may cause a problem.
- Insert the accessory plug into the socket securely. If the plug is not inserted securely, it may heat excessively and blow the fuse.
- Do not use accessories that have a power consumption of over 120 W (DC12V-10A). Otherwise, it could cause a malfunction.
- Noise may occur on the audio playback depending on the device connected to the accessory socket.
- Do not insert the cigarette lighter into the accessory socket.
- Depending on the device connected to the accessory socket, the vehicle's electrical system might be affected, which could cause the warning light to turn on. Disconnect the connected device and make sure that the problem is resolved. If the problem is resolved, switch the vehicle power OFF after the device is disconnected from the socket. If the problem is not resolved, consult an expert repairer (we recommend an Authorised Mazda Repairer).

How to Use the Accessory Socket

Open the lid and insert the plug to be used.

Front

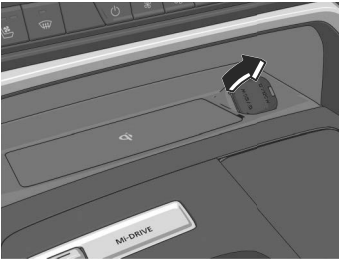

Rear

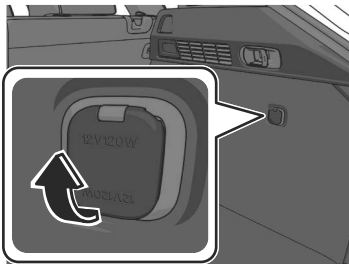

AC Power Outlet (220 V/150 W)*

The AC power outlet can be used as a socket for accessories when the vehicle power is switched to ACC or ON. Only use AC 220 V/50 Hz accessories that have a maximum power consumption of 150 W or below.

Warnings and Cautions When Using the AC Power Outlet (220 V/150 W)

WARNING

Never use medical instruments with the power outlet.

Otherwise, the operation of the medical device might be affected.

Heed the following cautions when using the AC power supply to prevent electrical shock, smoking, or combustion.

- Be careful with the AC power outlet and plug during and after use.
- Because an electrical appliance could operate at the moment it is plugged in, check the safety before plugging it in.
- Do not plug accessories into the power outlet or unplug them with wet hands.
- Be careful not to allow liquid to penetrate the AC power outlet.
- Do not put anything other than plugs into the AC power outlet.
- Do not disassemble the AC power outlet.
- Do not use the AC power outlet if it is damaged. If part replacement or repair is required, consult an expert repairer (we recommend an Authorised Mazda Repairer).

CAUTION

- Always close the cover when it is not in use. If foreign matter or liquid penetrates the AC power outlet, it may cause a problem.

- Insert electrical appliance plugs into the AC power outlet securely. If the plug is not inserted securely, it may heat excessively and blow a fuse.
- Do not connect multiple electrical appliances to the AC power outlet. Otherwise, it could cause smoking or combustion.
- Do not use electrical appliances that exceed the prescribed power capacity. Otherwise, it could cause a malfunction.

How to Use the AC Power Outlet (220 V/150 W)

Open the lid and insert the plug to be used.

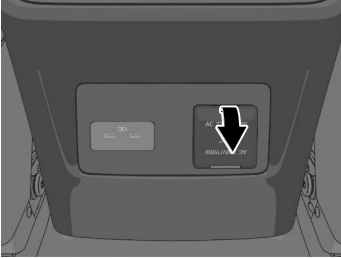

NOTE

- Use electrical appliances only in the cabin. If they are used outside of the vehicle cabin, they may not operate correctly due to noise.
- The following electrical appliances may not operate even if their electrical capacity is 150 W or lower.
 - Appliances requiring large amounts of power for activation (such as refrigerators with a compressor, electrical pumps, and electrical tools)
 - Appliances with a power supply frequency switch function (such as clocks and audio)
 - Appliances for precise data processing (such as measurement equipment)
- Electrical appliances other than the above may be used.
- When using an electrical appliance for data processing such as a personal computer, back up the data frequently.
- The protection function operates and the AC power outlet cannot be used in the following cases:
 - Lead-acid battery power is weak
 - Appliances with a capacity of 150 W or higher are used
 - Cabin temperature is extremely hot
- Noise may occur during radio operation depending on the electrical appliance being used.
- To prevent the lead-acid battery from depleting, do not use the socket for long periods with the engine stopped.

USB Power Outlet*

Only use USB devices with the following maximum power consumption.

- Type A (12 W (DC 5 V, 2.4 A)) or lower
- Type C (15 W (DC 5 V, 3 A)) or lower

Warnings and Cautions When Using the USB Power Outlet

CAUTION

- Insert the USB plug into the USB power supply socket securely. If the USB plug is not inserted securely, it may heat excessively and blow the fuse.
- Do not use USB devices that have a power consumption which exceeds the following. Otherwise, it could cause a malfunction.
 - Type A (12 W (DC 5 V, 2.4 A)) or lower
 - Type C (15 W (DC 5 V, 3 A)) or lower

How to Use the USB Power Outlet

Insert the plug to be used.

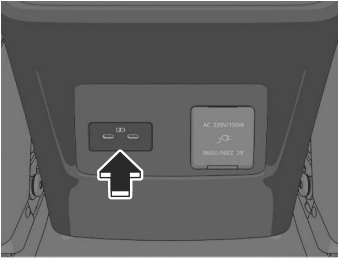

Wireless Charger (Qi)

Wireless Charger (Qi)*

You can charge mobile devices such as Smartphones which comply with the Qi Wireless Charging standard.

Only use mobile devices that have a maximum power consumption of 5 W, or 15 W or below.

Trademarks

“Qi” and the Qi symbol are trademarks or registered trademarks of the Wireless Power Consortium (WPC).



Warnings and Cautions When Using the Wireless Charger (Qi)

WARNING

Radio waves from the Wireless Charger (Qi) may affect the operation of medical devices such as implanted-type cardiac pacemakers or defibrillators.

- Before using the Wireless Charger (Qi) near people who use medical devices, ask the medical device manufacturer or your physician if radio waves from the Wireless Charger (Qi) will affect the device.
- The Wireless Charger (Qi) can be disabled to prevent it from affecting medical devices. Consult an expert repairer (we recommend an Authorised Mazda Repairer) for details.

Heed the following cautions. Otherwise, the Wireless Charger (Qi) may malfunction or be damaged, which could cause a fire, burns due to heat generation, or an accident such as electrical shock.

- Do not install, remove, disassemble, or change the wiring of the Wireless Charger (Qi). If the Wireless Charger (Qi) needs to be installed or removed, consult an expert repairer (we recommend an Authorised Mazda Repairer).

Wireless Charger (Qi)

- Do not use the Wireless Charger (Qi) when it is malfunctioning. In addition, if smoke, abnormal noise, or abnormal smell is emitted from the Wireless Charger (Qi), stop the vehicle in a safe place, turn off the Wireless Charger (Qi), and consult an expert repairer (we recommend an Authorised Mazda Repairer).
 - When using the Wireless Charger (Qi) to store items on, turn off the Wireless Charger (Qi).
 - Do not place any metal object between the charging area and the mobile device. Also, do not apply items such as a metallic sticker to the Wireless Charger (Qi).
 - When charging, do not place any item other than the mobile device to be charged on the Wireless Charger (Qi). In addition, do not place any metal object, IC card, coin, or magnetic item near the charging area.
 - Remove dust or dirt from the charging area before use.
 - Do not apply strong force or impact to the Wireless Charger (Qi) or get it wet.
 - Use only mobile devices which support the Wireless Charger (Qi).
- 
CAUTION
- While a mobile device is placed on the charging area, keep the vehicle key away from the Wireless Charger (Qi). The vehicle key may not be detected due to radio wave interference by the Wireless Charger (Qi).
 - Charging may not operate normally under the following conditions:
 - The mobile device is fully charged.
 - There is foreign matter between the mobile device and the charging area.
 - The temperature of the mobile device is high.
 - The mobile device is placed with the charging side facing upward.
 - The mobile device is placed in a position extremely deviating from the centre of the charging area.
 - Your vehicle is in an area where strong radio waves or electrical noise occur such as near a television tower, power plant, or airport.
 - The Near Field Communication (NFC) function setting of the mobile device is on (depends on the model of the mobile device).
 - Keep the following items away from the charging area. Otherwise the data stored on the mobile device could be erased or the device could malfunction.
 - Magnetic items such as magnets, magnetic cards, and magnetic recording media.
 - High precision devices such as wristwatches.
 - Before using the Wireless Charger (Qi), make sure to back up the data stored on the mobile device. The data on the mobile device could be deleted.
 - Do not wipe the Wireless Charger (Qi) using oil, alcohol, or thinner, or spray hairspray or insecticide onto it. Otherwise, it could cause damage or cracking.
 - Do not leave mobile devices in the cabin. The temperature inside the cabin may become very hot, causing the devices to malfunction.

Wireless Charger (Qi)

How to Use the Wireless Charger (Qi)

1. Start the engine.
The power for the Wireless Charger (Qi) turns on and the LED indicator turns on.
2. Place a device compliant with the Qi Wireless Charging standard (portable device with a maximum power consumption of 5 W or 15 W or below) in the centre of the charging area on the tray.

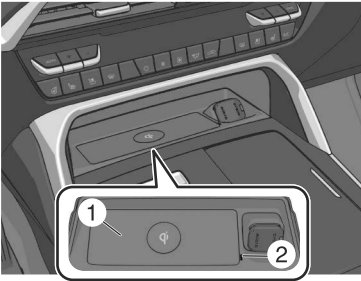

1. Charging area
2. LED indicator

The LED indicator turns on in amber or green when charging starts. Charging starts when all the doors and liftgate are closed.

For details on the LED indicator, refer to the following LED indicator table.

Charging status display

The charging status of the Wireless Charger (Qi) can be checked with the LED indicator or the icon displayed on the centre display.

Illumina-tion/flash pattern	Icon indi-cation	Status
Does not turn on	—	Indicates that charging is turned off.

Illumina-tion/flash pattern	Icon indi-cation	Status
Turns on in white		Indicates that charging is possible.
Turns on in amber		Indicates normal charging.
Turns on in green		Indicates fast charging* ¹ .
Flashes in white		Indicates that the charging conditions are not met.
Flashes in red		Indicates that charging is not possible because a high temperature is detected.
		Indicates that charging is not possible because foreign matter is detected.
Turns on in red		Indicates that there is a problem with Wireless Charger (Qi) and it needs to be repaired. Consult an expert repairer (we recommend an Authorised Mazda Repairer).

- *¹ Some mobile devices can switch between normal charging and fast charging.

NOTE

- Charging efficiency may be reduced or charging may not be possible depending on the use environment and conditions.
- Depending on the mobile device case or accessories used, the mobile device may not charge, or the charging efficiency may be reduced resulting in a longer charging time. If charging does not start even when a mobile device is placed on the charging area, remove the case or accessory.
- Depending on the vehicle condition, charge amount may be temporarily restricted and charging may be cancelled, however, this does not indicate a problem.
- If the mobile device temperature rises during charging, charging may stop due to the protection function of the device. If that happens, wait until the mobile device cools down sufficiently and then recharge it.
- When using the Wireless Charger (Qi), applications using the Near Field Communication (NFC) function may launch, however, this does not indicate a problem with the Wireless Charger (Qi).
- Charging may be temporarily cancelled depending on the vehicle conditions, such as when the engine is stopped.

Convenient Ways to Use the Wireless Charger (Qi)

The Wireless Charger (Qi) can be turned on/off and the connection mode can be switched.

Refer to the Settings section in the Mazda Connect Owner's Manual.

Warnings and Cautions When Using the Assist Grips

⚠ WARNING

Never hang heavy or sharp objects on the assist grips and coat hooks. Hanging heavy or sharp-ended objects such as a coat hanger from the assist grips or coat hooks is dangerous as they can fly off and hit an occupant in the cabin if a curtain air bag was to deploy, which could result in serious injury or death.

Do not use the assist grips when getting in and out of the vehicle or getting out of a seat. An assist grip could break under a heavy load resulting in injury.

Using the Assist Grips

Use the assist grips to support your body while seated in the vehicle and while the vehicle is moving.



Luggage Compartment Cover*

Cargo can be covered in the luggage compartment by storing it under the luggage board.

Warnings and Cautions for Using the Luggage compartment cover

WARNING

Do not place any objects or cargo on the Luggage compartment cover.

If you leave any objects or cargo on the Luggage compartment cover, it may move during sudden braking resulting in an unexpected accident.

CAUTION

Make sure that the Luggage compartment cover is fixed securely. If the Luggage compartment cover is used without being secured, it may come off unexpectedly while the vehicle is being driven, resulting in injury.

Luggage compartment cover

How to Use the Luggage Compartment Cover

When hanging the clips on the hooks of the liftgate, the luggage compartment cover opens and closes at the same time as the liftgate.

To Remove the Luggage Compartment Cover

1. Hold the knob and lift the luggage compartment cover with both hands to remove it from the clip.

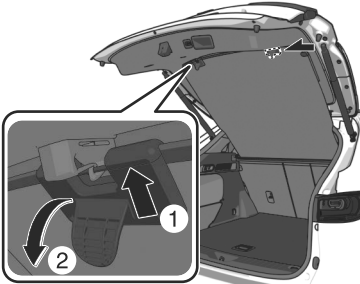

2. Let the luggage compartment cover roll up.
3. Compress either the left or right luggage compartment cover holder inwards.

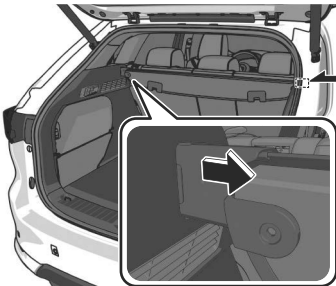

4. Pull the luggage compartment cover toward you and remove it from the installation hole.
5. Remove the luggage compartment cover from the vehicle at an angle.

To Store the Luggage Compartment Cover

1. Open the luggage board.

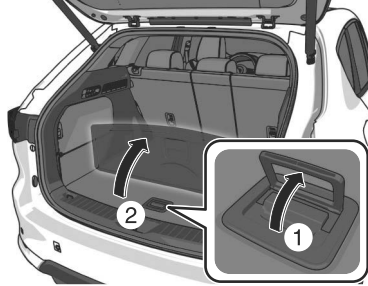

2. Store one side of the luggage compartment cover under the side board.

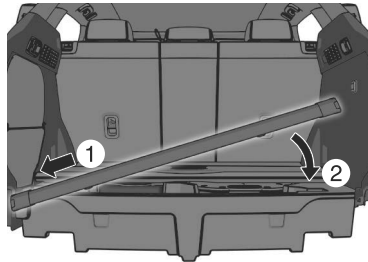

3. Then store the other side.

To Install the Luggage Compartment Cover

Install in the reverse order of removal.

Partition Net*

There are partition nets for the front and rear sides.

Warnings and Cautions For Using the Partition Net

CAUTION

- Make sure the net is firmly secured. If it is not firmly secured, it could unexpectedly disengage resulting in injury.
- Always close the net anchor covers when the partition nets are not in use.

How to Use the Partition Net

Front

Installing

1. Fold down the rear seatback.
2. Open the net anchor cover.

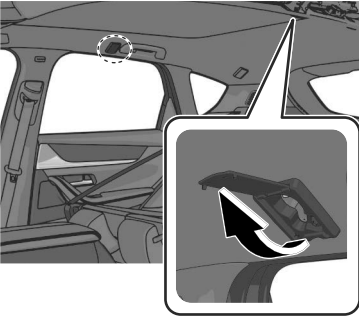

3. Attach the net anchor.

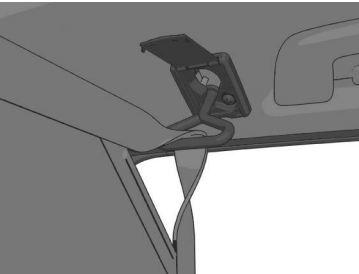

4. Pull up the partition net knob.

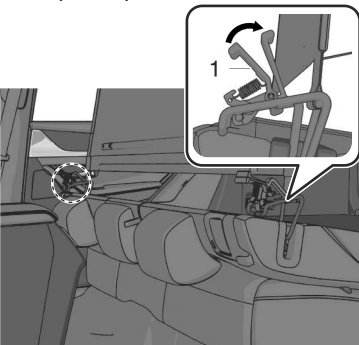

1. Partition net knob

5. Align the partition net knob with the stopper and tilt it down.

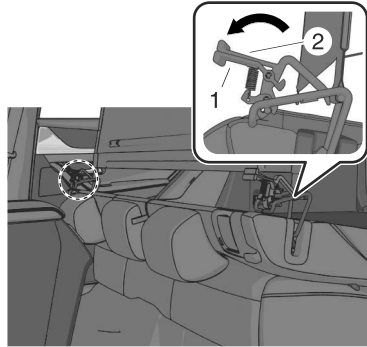

1. Partition net knob
2. Stopper

6. Pull the seatback lever to move the seat hook.

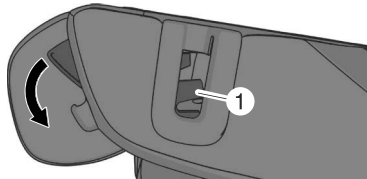

1. Seat hook

7. Insert the net anchor into the seat hook while pulling the seatback lever.

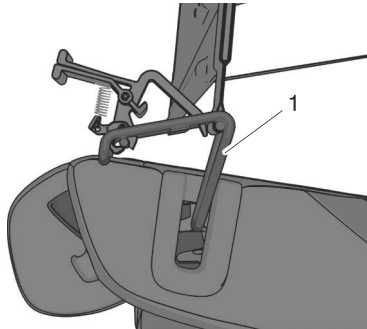

1. Net anchor
8. Return the seatback lever to its original position.

9. Pull up the stopper and the knob and insert the stopper.

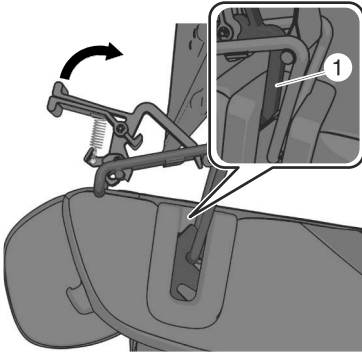

1. Stopper

10. Attach the net hook to the seat striker.

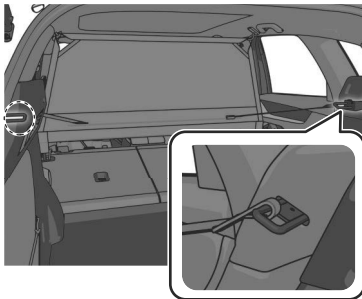

Removing

1. Remove the net hook from the seat striker.

2. Pull up the knob, align it with the stopper, and then tilt it towards the vehicle front to pull out the stopper.

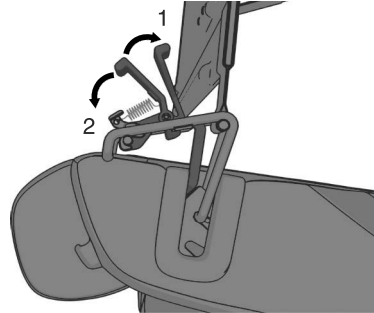

3. Remove the net anchor from the seat hook while pulling the seatback lever.
4. Remove the net anchor.
5. Close the net anchor cover.
6. Return the rear seatback to its upright position.

Rear

1. Open the net anchor cover.

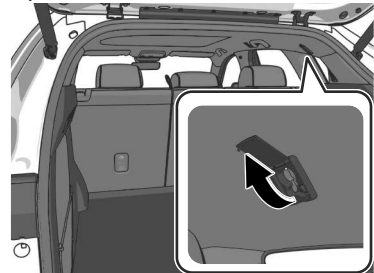

2. Attach the net anchor.



Partition Net

3. Attach the partition net hook to the cargo hook.



NOTE

The width of the net anchors can be shortened by pushing both sides inward.

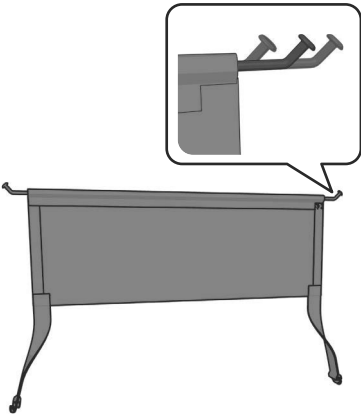

For removal, perform the installation procedure in the reverse order.

Towing (Europe/Russia/ Israel/South Africa)

Your Mazda was designed and built primarily to carry passengers and cargo.

If you tow a trailer, follow these instructions because driver and passenger safety depends on proper equipment and safe driving habits. Towing a trailer will affect handling, braking, durability, performance, and economy.

Never overload vehicle or trailer. Consult an expert repairer (we recommend an Authorised Mazda Repairer) if you need further details.

NOTE

• When towing a trailer, do not use the following safety systems (If a Mazda genuine trailer hitch is used, these systems are automatically turned off when the trailer's electrical connector is connected):

- Blind Spot Monitoring (BSM)
- Rear Cross Traffic Alert (RCTA)
- Smart Brake Support (SBS) reverse drive detection
- Parking Sensor System (Rear)
- Emergency Lane Keeping (ELK) Blind Spot Assist

Turn off the aforementioned safety systems when towing a trailer without a genuine Mazda trailer hitch.

• Your vehicle is equipped with a Mazda intelligent Drive Select (Mi-Drive) towing mode which enhances vehicle stability when towing a trailer. Refer to Mazda intelligent Drive Select (Mi-Drive) on page 5-107.

Warnings and Cautions for Using the Towing

WARNING

Always keep tow loads within specified limits as indicated in the Trailer Towing-Load Table.

Attempting to tow loads greater than those specified is dangerous as it may cause serious handling and performance problems that could result in personal injury or vehicle damage, or both.

Always keep the trailer nose weight within the specified limits in the Trailer Towing-Load Table.

Loading the trailer with more weight in the rear than in the front is dangerous. This could cause loss of vehicle control and an accident.

CAUTION

- Do not tow a trailer during the first 1,000 km (600 miles) of your new Mazda. If you do, you may damage the engine, transmission, differential, wheel bearings, and other power train components.
- Damage caused by towing a trailer/caravan in Israel, South Africa is not covered by the vehicle's warranty.

Towing

➤ Be aware of the towing load weight differences when towing at high altitudes. For altitudes exceeding 1,000 meter (3,280 ft 10 in), always reduce the towing load by 10 % for every 1,000 meter (3,280 ft 10 in) increase in altitude from the load indicated under the gross combination weight heading in the maximum trailer towing-load table. If the determined maximum total towing load weight is exceeded, the engine and other power train parts may be damaged.

NOTE

- The total trailer weight and nose weight can be determined by weighing the trailer on platform scales at a highway weighing station or a trucking company.
- Appropriate total trailer weight and nose weight may prevent the danger of trailer sway from crosswinds, rough roads, or other causes.

How to Use the Towing

Trailer Hitch

When towing a trailer, use an appropriate trailer hitch. We recommend using a genuine Mazda trailer hitch. Use the original holes drilled by the vehicle manufacturer for securing the trailer hitch. Consult an expert repairer (we recommend an Authorised Mazda Repairer) for more information.

Do not install a trailer hitch that is not easy to remove or reposition if there is the possibility that a part of the trailer hitch partially obscures the lighting system and/or rear number plate.

If a trailer hitch that is easy to remove or reposition is installed, make sure to remove or reposition it when it is not in use.

Trailer hitch installation area

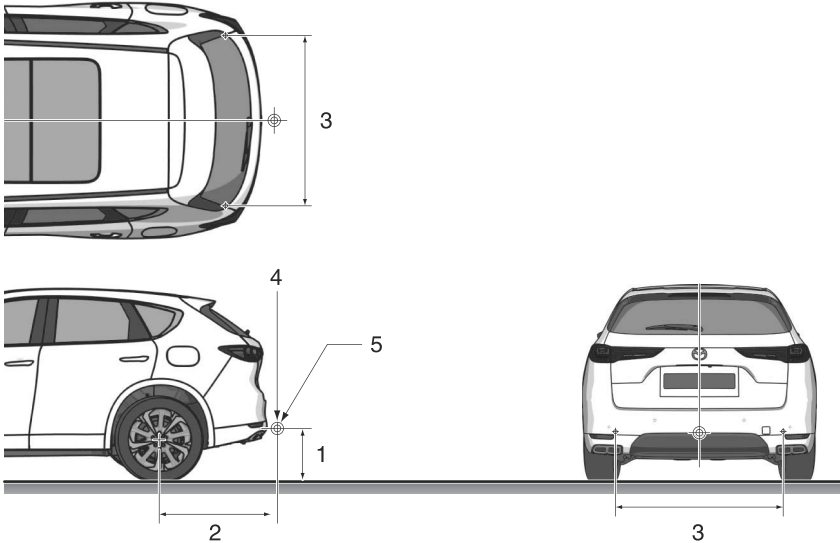

1. 350 — 420 mm (13.8 — 16.5 in)
2. 1105.0 mm (43.504 in)
3. 1065.56 mm (41.951 in)
4. MAX. 100 kg (220 lb)
5. Hitch coupling point

Weight Limits

The total trailer weight, gross combination weight and trailer nose weight must be within the prescribed limits in the Trailer Towing-Load Table.

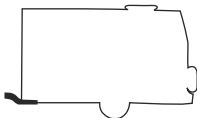
TOTAL TRAILER WEIGHT:

Sum of weights of the trailer and its load.

GROSS COMBINATION WEIGHT:

Sum of total trailer weight and towing vehicle weight; including trailer hitch, vehicle passengers, and vehicle load.

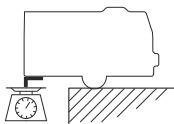
TRAILER NOSE WEIGHT:

The weight exerted on the trailer tongue. It is varied by changing the weight distribution when loading the trailer.

Maximum trailer towing-load table

Europe/Gradient up to 12 %

MODEL			TOTAL TRAILER WEIGHT		GROSS COMBINATION WEIGHT
Engine	Transmission	Drive system	Trailer without brake	Trailer with brake	Trailer with brake
e-SKYACTIV D	Automatic transmission	RWD	750 kg (1,653.4 lb)	2,500 kg (5,511.5 lb)	5,000 kg (11,023.0 lb)
e-SKYACTIV D	Automatic transmission	AWD	750 kg (1,653.4 lb)	2,500 kg (5,511.5 lb)	5,016 kg (11,058.2 lb)

Left-hand drive model (RWD)

TRAILER NOSE WEIGHT: 80 kg (176.3 lb)

Except left-hand drive model (RWD)

TRAILER NOSE WEIGHT: 100 kg (220.4 lb)

Germany and Austria/Gradient up to 8%

MODEL			TOTAL TRAILER WEIGHT		GROSS COMBINATION WEIGHT
Engine	Transmission	Drive system	Trailer without brake	Trailer with brake	Trailer with brake
e-SKYACTIV D	Automatic transmission	RWD	750 kg (1,653.4 lb)	2,500 kg (5,511.5 lb)	5,000 kg (11,023.0 lb)
e-SKYACTIV D	Automatic transmission	AWD	750 kg (1,653.4 lb)	2,500 kg (5,511.5 lb)	5,016 kg (11,058.2 lb)

RWD

TRAILER NOSE WEIGHT: 80 kg (176.3 lb)

AWD

TRAILER NOSE WEIGHT: 100 kg (220.4 lb)

Russia/Gradient up to 12%

MODEL			TOTAL TRAILER WEIGHT		GROSS COMBINATION WEIGHT
Engine	Transmission	Drive system	Trailer without brake	Trailer with brake	Trailer with brake
e-SKYACTIV G	Automatic transmission	AWD	750 kg (1,653.4 lb)	2,500 kg (5,511.5 lb)	5,000 kg (11,023.0 lb)
SKYACTIV-G	Automatic transmission	RWD	750 kg (1,653.4 lb)	2,000 kg (4,409.2 lb)	4,274 kg (9,422.4 lb)
SKYACTIV-G	Automatic transmission	AWD	750 kg (1,653.4 lb)	2,000 kg (4,409.2 lb)	4,342 kg (9,572.3 lb)

TRAILER NOSE WEIGHT: 80 kg (176.3 lb)

Israel/Gradient up to 12%

MODEL			TOTAL TRAILER WEIGHT		GROSS COMBINATION WEIGHT
Engine	Transmission	Drive system	Trailer without brake	Trailer with brake	Trailer with brake
SKYACTIV-G	Automatic transmission	AWD	750 kg (1,653.4 lb)	1,500 kg (3,306.9 lb)	3,876 kg (8,545.0 lb)
SKYACTIV-G	Automatic transmission	RWD	750 kg (1,653.4 lb)	1,500 kg (3,306.9 lb)	3,828 kg (8,439.2 lb)

TRAILER NOSE WEIGHT: 80 kg (176.3 lb)

South Africa/Gradient up to 12%

MODEL			TOTAL TRAILER WEIGHT		GROSS COMBINATION WEIGHT
Engine	Transmission	Drive system	Trailer without brake	Trailer with brake	Trailer with brake
SKYACTIV-G	Automatic transmission	RWD	750 kg (1,653.4 lb)	1,500 kg (3,306.9 lb)	3,794 kg (8,364.2 lb)
SKYACTIV-G	Automatic transmission	AWD	750 kg (1,653.4 lb)	1,500 kg (3,306.9 lb)	3,842 kg (8,470.0 lb)
e-SKYACTIV D	Automatic transmission	AWD	750 kg (1,653.4 lb)	1,500 kg (3,306.9 lb)	3,993 kg (8,802.9 lb)

TRAILER NOSE WEIGHT: 80 kg (176.3 lb)

Tyres

When towing a trailer, make sure that the tyre pressures of the rear tyres are at 20 kPa (0.2 bar, 2.9 psi) higher than the recommended maximum tyre pressures indicated on the tyre pressure chart on the driver's door frame.

Trailer tyre size, load rating, and inflation pressures should conform to tyre manufacturer specifications.



Never use the temporary spare tyre when towing:

Using the temporary spare tyre on your vehicle when towing a trailer is dangerous as it could result in tyre failure, loss of control, and injury to vehicle occupants.

Safety Chains

Safety chains must be used as a precautionary measure should the trailer become unintentionally unhitched. They should cross under the trailer tongue and attach to the hitch. Leave enough slack to allow full turns. Consult literature published by your trailer or hitch manufacturer for more details.



Make sure the safety chain is securely attached to both the trailer and the vehicle prior to departure.

Towing a trailer without using a safety chain securely attached to both the trailer and the vehicle is dangerous. If damage occurs to the coupling unit or hitch ball, the trailer could wander into another lane and cause a collision.

Trailer Lights



Do not connect a trailer lighting system directly to the lighting system of your Mazda. This may damage your vehicle's electrical system and lighting systems. To connect the lighting system, consult an expert repairer (we recommend an Authorised Mazda Repairer)

Trailer Brakes

Check the Maximum trailer towing-load table in Weight Limits , and if your trailer weight exceeds the value in the TOTAL TRAILER WEIGHT (Trailer without brake), trailer brakes are required.

If your trailer has brakes, make sure they meet regulations.



Do not connect a hydraulic trailer-brake system to your vehicle's brake system. Connecting a hydraulic trailer-brake system directly to the vehicle brake system is dangerous and will result in inadequate braking and possible injury.

Before driving

- Verify that your Mazda maintains a near-normal attitude when a loaded or unloaded trailer is connected. Do not drive if it has an abnormal front-up or front-down position. Inspect for incorrect nose weight, worn suspension parts, and trailer overloading. Have the vehicle inspected by an expert repairer (we recommend an Authorised Mazda Repairer).
- Make sure the trailer cargo is secure to prevent it from shifting.
- Make sure the mirrors meet all government regulations. Inspect them.
- Before starting out, inspect the operation of all vehicle and trailer lights and all vehicle-to-trailer connections. Stop and re-inspect all lights and connections after driving a short distance.

Driving

- Your Mazda will handle differently with a trailer in tow, so practice turning, backing, and stopping in a traffic-free area.
- Take time to get accustomed to the extra weight and length.
- Do not exceed 100 km/h (62 mph) with a trailer in tow. If the local legal maximum speed with a trailer in tow is less than 100 km/h (62 mph), do not exceed the legal speed.



If the vehicle exceeds 100 km/h (62 mph) with a trailer in tow, the vehicle could be damaged.

- When ascending a hill, shift into a lower gear to reduce the possibility of overloading or overheating the engine, or both.
- When descending a hill, shift into a lower gear and use engine compression as a braking effect. Pay constant attention to speed and use the brakes only as needed. Holding the brake pedal down for a prolonged period may cause the brakes to overheat and lose power.

Parking

Avoid parking on an incline with a trailer. If this must be done, follow these instructions.

Parking on an Incline

1. Set the parking brake and the brakes.
2. Have someone block the wheels of the vehicle and trailer while you apply the brakes.
3. After the wheels are blocked, release the parking brake and the brakes slowly, allowing the blocks to bear the load.
4. Set the parking brake firmly.
5. Put the selector lever in P position.

Starting on an Incline

1. Start the engine (page 5-16).
2. Release the parking brake and slowly pull away a short distance from the wheel blocks.
3. Stop on the nearest level ground, set the parking brake, and pick up the wheel blocks.

Warnings and Cautions For Using the Accessories

 **CAUTION**

When installing accessories using electrical or electronic components, consult an expert repairer (we recommend an Authorised Mazda Repairer).

There is a possibility of accidents due to brake or air bag mis-operation, vehicle damage or malfunctions.

Warnings and Cautions For Using the Floor Mat

We recommend the use of **Genuine Mazda floor mats**.

! WARNING

Make sure the floor mats are secured with the grommets to prevent them from bunching up under the foot pedals (Driver's side).

Using a floor mat that is not secured is dangerous as it will interfere with the accelerator and brake pedal operation (driver's side), which could result in an accident.

Only use a floor mat which conforms to the shape of the floor on the driver's side and make sure it is oriented correctly.

Secure the floor mat using the grommets.

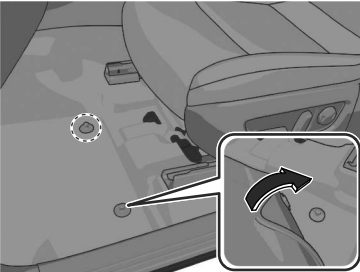

There are various ways to secure floor mats depending on the type used, therefore secure the mat according to the type.

After installing the floor mat, make sure that it does not slide from side to side or back and forth, and that there is sufficient clearance with the accelerator and brake pedals on the driver's side.

After removing the floor mat for cleaning or some other reason, always securely reinstall it while paying attention to the precautions just mentioned.

Do not install two floor mats, one on top of the other, on the driver's side.

Installing two floor mats, one on top of the other, on the driver's side is dangerous as the retention pins can only keep one floor mat from sliding forward.

Loose floor mat(s) will interfere with the foot pedals and could result in an accident.

If using an all-weather mat for winter use always remove the original floor mat.

Malfunction Diagnosis Connector

CAUTION

Do not connect any devices other than the specially designed malfunction diagnosis devices for servicing. If any device other than the malfunction diagnosis device is connected, it may affect the vehicle's electrical devices or lead to damage such as lead-acid battery depletion.

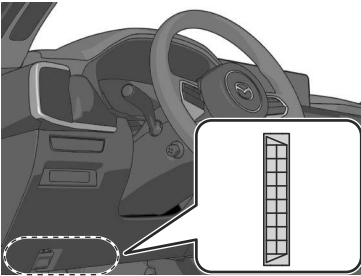

Spare Tyre and Tool Storage

Jack*

To remove the jack

1. Remove the luggage board.

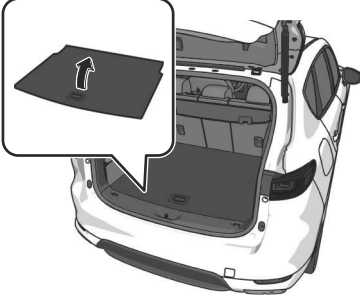

- 2.

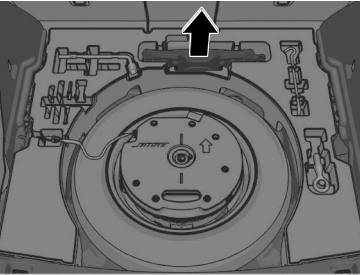

To secure the jack

Perform the removal procedure in reverse.

Maintenance

- Always keep the jack clean.
- Make sure the moving parts are kept free from dirt or rust.
- Make sure the screw thread is adequately lubricated.

Spare Tyre*

The temporary spare tyre is lighter and smaller than a conventional tyre, and is designed only for emergency use and should be used only for VERY short periods. Temporary spare tyres should NEVER be used for long drives or extended periods.

! WARNING

Do not install the temporary spare tyre on the rear wheels (driving wheels).

Driving with the temporary spare tyre on one of the rear driving wheels is dangerous. Handling will be affected. You could lose control of the vehicle, especially on ice or snow bound roads, and have an accident. Move a regular tyre to the rear wheel and install the temporary spare tyre to the front.

! CAUTION

- When using the temporary spare tyre, driving stability may decrease compared to when using only the conventional tyre. Drive carefully.
- To avoid damage to the temporary spare tyre or to the vehicle, observe the following precautions:
 - Do not exceed 80 km/h (50 mph).
 - Avoid driving over obstacles. Also, do not drive through an automatic car wash. This tyre's diameter is smaller than a conventional tyre, so the ground clearance is reduced.
 - Do not use a tyre chain on this tyre because it will not fit properly.

Spare Tyre and Tool Storage

- Do not use your temporary spare tyre on any other vehicle, it has been designed only for your Mazda.
- Use only one temporary spare tyre on your vehicle at the same time.

To remove the spare tyre

1. Remove the luggage board.

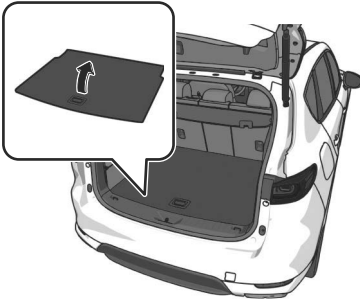

2. **(Vehicles with sub-woofer)**
Uncouple the sub-woofer connector.

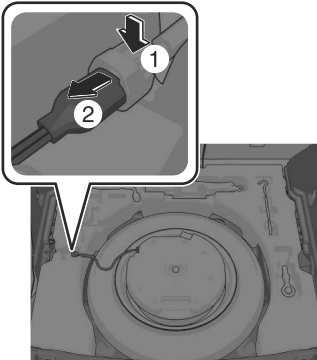

NOTE

Extra strength may be required to uncouple the connector. Be sure to squeeze the tab firmly.

3. **(Vehicles with sub-woofer)**
Turn the spare tyre hold-down bolt anticlockwise and remove the sub-woofer and the spare tyre.

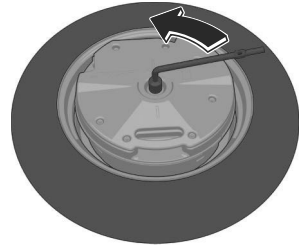

- (Vehicles without sub-woofer)**
Turn the spare tyre hold-down bolt anticlockwise and remove the spare tyre.

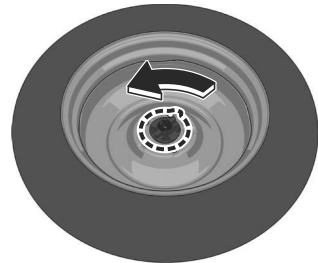

NOTE

If the spare tyre hold-down bolt cannot be loosened, hold the edge of the tyre and turn it anticlockwise until the spare tyre hold-down bolt rotates.

To secure the spare tyre

Store the spare tyre in the reverse order of removal. After storing, verify that the spare tyre is stored securely.

Screwdriver and Wrench*

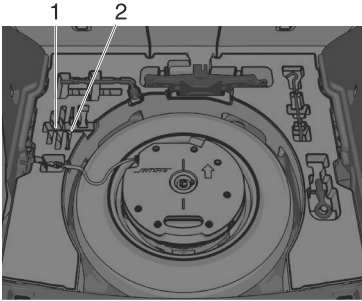

1. Wrench
2. Screwdriver

8

What to Do in Case of Emergency

In Case of Emergency.....	8-4
Dealing With an Accident.....	8-4
Make a Mazda Emergency Call.....	8-4
When Towing is Required.....	8-5
Having the Vehicle Towed.....	8-5
Using the Towing Hooks.....	8-6
Key Does Not Operate.....	8-8
Cancelling the Key Temporary Suspension Function.....	8-8
Unlocking Using the Auxiliary Key.....	8-8
Starting the engine with a dead battery key.....	8-9
Engine Does Not Start.....	8-11
Taking Action with Depleted Lead-acid Battery.....	8-11
Starting a Flooded Engine.....	8-16
Engine Cannot be Stopped.....	8-17
Forcibly Stopping the Engine.....	8-17
Problem With the Brake System (Foot Brake).....	8-18
Applying the Emergency Brake.....	8-18
AUTOHOLD Cannot be Cancelled.....	8-19
Forcibly Cancelling the AUTOHOLD.....	8-19
Overheating.....	8-20
Taking Action with Overheating.....	8-20
Tyre is Punctured or Bursts.....	8-22
Using the Emergency Flat Tyre Repair Kit*.....	8-22
Changing a Flat Tyre (With Spare Tyre)*.....	8-27
Liftgate Cannot Open.....	8-33
Open the liftgate from the luggage compartment.....	8-33
The Power Windows Cannot Be Operated.....	8-34
Initializing the Power Window.....	8-34
The Panorama Sunroof Cannot Be Operated.....	8-35
Initializing the Panorama Sunroof.....	8-35
Windscreen Wipers Operate at High Speed.....	8-36
Have the Vehicle Inspected.....	8-36

Washer Fluid Does Not Spray	
.....	8-37
Inspecting Washer Fluid	
Level.....	8-37

Active Driving Display Does Not Operate	8-38
Active Driving Display Does Not Operate.....	8-38

Warning/Indicator Light Turns On	8-39
Warning Lights.....	8-39
Brake System Warning Light (Red).....	8-39
Charging System Warning Light.....	8-40
Hybrid System Warning Light*	8-41
Engine Oil Warning Light.....	8-41
High Engine Coolant Temperature Warning Light.....	8-42
Electric Power Steering Warning Light.....	8-42
Shift System Warning Light	8-43
ABS Warning Light.....	8-43
Master Warning Light.....	8-44
Brake Control System Warning Light (Amber).....	8-44
Electric Parking Brake (EPB) Indicator Light.....	8-45
Check Engine Warning Light.....	8-45
i-stop Warning Light (Amber)*	8-46
Petrol Particulate Filter Warning Light*	8-46
Diesel Particulate Filter Warning Light*	8-47

Automatic Transmission Warning Light.....	8-47
AWD Warning Light*	8-48
120 km/h Warning Light*	8-48
Tyre Pressure Monitoring System (TPMS) Warning Light (Flashing)*	8-49
TCS/DSC Indicator Light (Turns on).....	8-49
Air Bag/Seat Belt Pretensioner System Warning Light.....	8-50
KEY Warning Light (Red).....	8-50
Security Indicator Light.....	8-51
High Beam Control System (HBC) Warning Light (Amber)*	8-51
Adaptive LED Headlights (ALH) Warning Light (Amber)*	8-52
i-ACTIVSENSE Warning Light.....	8-52
Exterior Lights Warning Light.....	8-53
Low Fuel Warning Light.....	8-53
Engine Oil Level Warning Light.....	8-54
Seat Belt Warning Light (Front Seat).....	8-54
Seat Belt Warning Light (Rear Seat) (Red).....	8-55
Low Washer Fluid Amount Warning Light*	8-55
Selective Catalytic Reduction (SCR) Warning Light*	8-56
Door-ajar Warning Light/Liftgate-open Warning Light/Bonnet-open Warning Light.....	8-56
KEY Indicator Light (Green) (Flashing).....	8-57
Wrench Indicator Light.....	8-57

Warning Sound is Activated..... 8-59

Lights-On Reminder..... 8-59
Power Switch Not Switched OFF
Reminder Warning Sound..... 8-59
Key Removed from Vehicle
Warning Sound..... 8-60
Key Left-in-Vehicle Warning
Sound..... 8-60
Key Left-In-Luggage
Compartment Warning Sound
(Vehicles With Advanced Keyless
Function)..... 8-61
Door Lock Inoperable Warning
Sound..... 8-61
Power Liftgate Warning Sound*
..... 8-62
Electronic Steering Lock Warning
Sound..... 8-62
Brake System Warning
Sound..... 8-63
Brake Override Warning
Sound..... 8-63

Electric Parking Brake (EPB)
Warning Sound..... 8-64
Vehicle Problem Warning
Sound..... 8-64
Shift Position Warning
Sound..... 8-65
Selector Lever Not in P Reminder
Warning Sound..... 8-65
Selective Catalytic Reduction
(SCR) Warning Sound* 8-66
Reverse Position Warning
Sound..... 8-66
Door-Ajar Warning Sound
..... 8-67
Low Lead-Acid Battery Charge
Warning Sound..... 8-67

If the Vehicle Becomes Stuck.... 8-68

What to do when the vehicle is
stuck..... 8-68

In Case of Emergency

Dealing With an Accident

In case of an accident, react calmly and perform as follows.

1. Prevention of secondary accident
Move the vehicle to a safe place (such as a shoulder or a vacant lot) where it does not obstruct traffic, and stop the engine.
2. Aiding injured person
If there is any injured person, provide any possible first aid until an ambulance or a doctor arrives. If someone has injured his or her head, do not move the person unnecessarily. However, move the person to a safe place if there is the possibility of a secondary accident.
3. Call the police
Provide information such as the location, conditions, and level of injury, and take directions.
4. Check the name and address of the other person.
5. Call an expert repairer (we recommend an Authorised Mazda Repairer) and insurance agency.

Make a Mazda Emergency Call

Connected service is available through the emergency call operator. Refer to How to Use the Emergency Call System on page 7-30.

Having the Vehicle Towed

We recommend that towing be done only by an expert repairer (we recommend an Authorised Mazda Repairer) or a commercial tow-truck service.

Proper lifting and towing are necessary to prevent damage to the vehicle. Particularly when towing an AWD vehicle, where all the wheels are connected to the drive train, proper transporting of the vehicle is absolutely essential to avoid damaging the drive system. Government and local laws must be followed.

WARNING

Always tow an AWD vehicle with all four wheels off the ground.

Towing an AWD vehicle with either the front or rear wheels on the ground is dangerous as the drive train could be damaged, or the vehicle could trail away from the tow truck and cause an accident. If the drive train has been damaged, transport the vehicle on a flatbed truck.

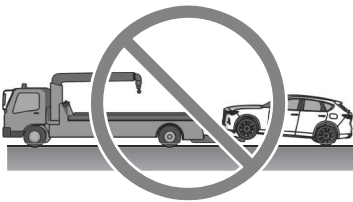

CAUTION

- Do not tow the vehicle pointed forward with driving wheels on the ground. This may cause internal damage to the transmission.

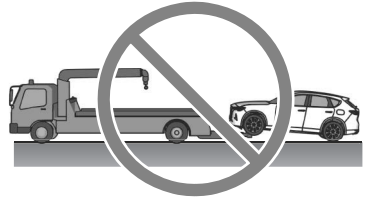

- Do not tow with sling-type equipment. This could damage your vehicle. Use wheel-lift or flatbed equipment.



- If the parking brake cannot be released when towing the vehicle, transport the vehicle with all front and rear wheels raised off the ground as shown in the figure. If the vehicle is towed without raising the wheels off the ground, the brake system could be damaged.

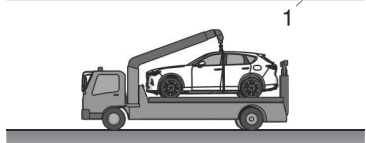
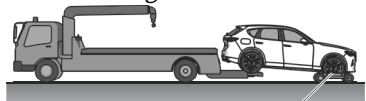

1. Wheel dollies

When Towing is Required

Using the Towing Hooks

CAUTION

- The towing eyelet should be used in an emergency (to get the vehicle out of a ditch or a snow bank, for example).
- When using the towing eyelets, always pull the lead or chain in a straight direction with respect to the eyelet. Never apply a sideways force.
- If the towing eyelet is not securely tightened, it may loosen or disengage from the bumper when towing the vehicle. Make sure that the towing eyelet is securely tightened to the bumper.
- Be careful not to damage the towing eyelet and towing hook or vehicle body when towing under the following conditions:
 - Do not tow a vehicle heavier than yours.
 - Do not suddenly accelerate your vehicle as it will apply a severe shock to the towing eyelet and towing hook or rope.
 - Do not attach any rope other than to the towing eyelet and towing hook.

NOTE

When towing with chain or lead, wrap the chain or lead with a soft cloth near the bumper to prevent damage to the bumper.

1. Remove the towing eyelet, the jack lever and the wheel brace or equivalent from the luggage compartment.

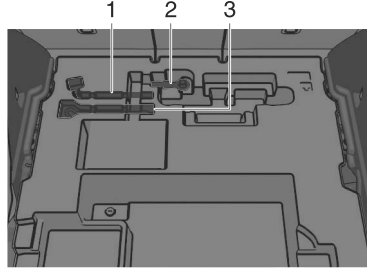

1. Wheel brace
2. Towing eyelet
3. Jack lever

2. Wrap a flathead screwdriver or jack lever or a similar tool with a soft cloth to prevent damage to a painted bumper, and open the cap located on the front or rear bumper.

Front

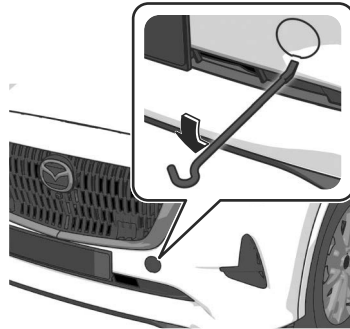

Rear

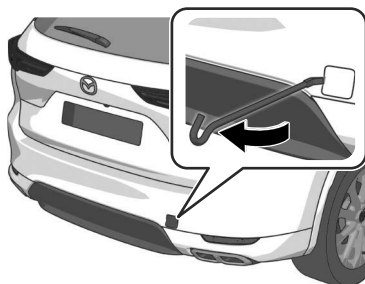

⚠ CAUTION

Do not use excessive force as it may damage the cap or scratch the painted bumper surface.

NOTE

Remove the cap completely and store it so as not to lose it.

3. Securely install the towing eyelet using the wheel brace, the jack lever or equivalent.

Front

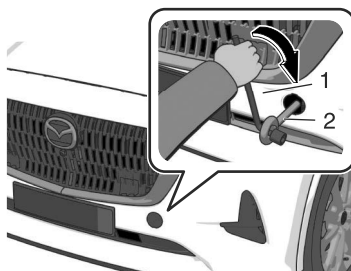

1. Wheel brace
2. Towing eyelet

Rear

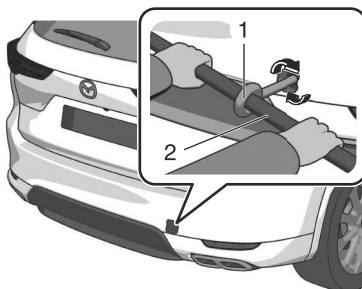

1. Jack lever
 2. Towing eyelet
4. Hook the towing rope to the towing eyelet.

Cancelling the Key Temporary Suspension Function

If a key is inside the vehicle, its functions might be temporarily suspended to prevent theft. In this case, press the unlock button on the suspended key in the vehicle to restore the functions.

Unlocking Using the Auxiliary Key

1. Remove the cover while pressing the knob.

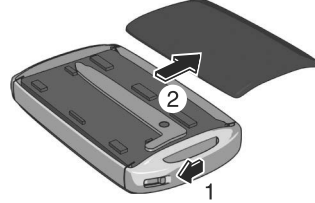

2. Remove the auxiliary key.
3. Insert the auxiliary key while pulling the driver's door handle.

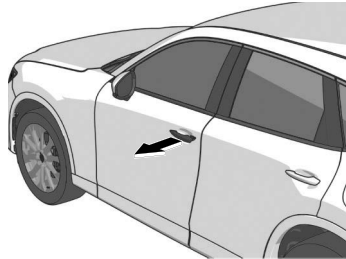

4. Turn the auxiliary key. The door is unlocked.

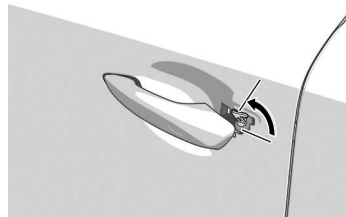

5. Attach the auxiliary key to its original position.

6. Insert the tabs of the cover.

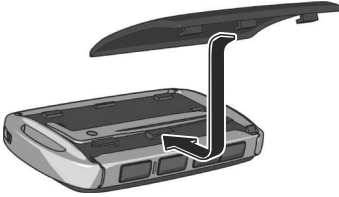

Starting the engine with a dead battery key

CAUTION

Do not allow the following conditions. Otherwise, the vehicle may not receive the correct signal from the key and the engine may not start.

- Metal parts of other keys or metal objects touch the key.



- Spare keys or keys for other vehicles equipped with an immobilizer system touch or come near the key.



- Equipment containing electronic components or cards with magnetic strips such as credit cards come near the key.

If the engine cannot be started due to a dead key battery, use the following procedure to start the engine.

1. Depress the brake pedal.
The push button start indicator light (green) flashes.
2. Align the centre of the key emblem with the centre of the push button start.

Key Does Not Operate

The push button start indicator light (green) turns on.

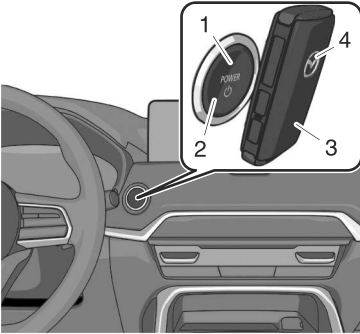

1. Indicator light
 2. Push button start
 3. Key
 4. Emblem
3. Press the push button start.

NOTE

- If there is a problem with the push button start function, the push button start indicator light (amber) flashes.
In this case, it is possible to start the engine, however, have the vehicle inspected by an expert repairer (we recommend an Authorised Mazda Repairer) as soon as possible.
- If the push button start indicator light (green) does not turn on, perform the operation from the beginning.
If it still does not turn on, have the vehicle inspected by an expert repairer (we recommend an Authorised Mazda Repairer).
- To change the vehicle power position, release the brake pedal after the push button start indicator light (green) turns on, then press the push button start.

The vehicle power position is switched in the order of ACC, ON, and OFF.

Once the vehicle power is switched OFF, the vehicle power position can no longer be changed. Therefore, to start the engine, perform the operation from the beginning.

Taking Action with Depleted Lead-acid Battery

The lead-acid battery might be depleted if the following conditions occur.

- The engine does not start.
- The selector lever cannot be shifted to a position other than P.
- The horn sound is weak or it does not sound.
- The brightness of the lights is extremely low.

Using commercially available booster leads, connect the lead-acid battery of the booster vehicle's battery to the lead-acid battery of your vehicle and start the engine. Jump-starting is dangerous if done incorrectly. Therefore, follow the procedure carefully. If you feel unsure about jump-starting, we strongly recommend that you have a competent service technician do the work.

WARNING



Read the following precautions carefully before using the lead-acid battery or inspecting to ensure safe and correct handling.



Always wear eye protection when working near the lead-acid battery.

Working without eye protection is dangerous. Lead-acid battery fluid contains SULPHURIC ACID which could cause blindness if splashed into your eyes. Also, hydrogen gas produced during normal lead-acid battery operation, could ignite and cause the lead-acid battery to explode.



Wear eye protection and protective gloves to prevent contact with lead-acid battery fluid.

Spilled lead-acid battery fluid is dangerous.

Lead-acid battery fluid contains SULPHURIC ACID which could cause serious injuries if it gets in eyes, or on the skin or clothing. If this happens, immediately flush your eyes with water for 15 minutes or wash your skin thoroughly and get medical attention.



Always keep lead-acid batteries out of the reach of children.

Allowing children to play near lead-acid batteries is dangerous. Lead-acid battery fluid could cause serious injuries if it gets in the eyes or on the skin.

Engine Does Not Start



Keep flames and sparks away from lead-acid battery cells and do not allow metal tools to contact the positive (+) or negative (-) terminal of the lead-acid battery when working near a lead-acid battery. Do not allow the positive (+) terminal to contact the vehicle body.

Flames and sparks near lead-acid battery cells are dangerous. Hydrogen gas, produced during normal lead-acid battery operation, could ignite and cause the lead-acid battery to explode. An exploding lead-acid battery can cause serious burns and injuries. Keep all flames including cigarettes and sparks away from lead-acid battery cells.



Keep all flames and sparks away from lead-acid battery cells because hydrogen gas is produced from lead-acid battery cells while charging the lead-acid battery or adding lead-acid battery fluid.

Flames and sparks near lead-acid battery cells are dangerous. Hydrogen gas, produced during normal lead-acid battery operation, could ignite and cause the lead-acid battery to explode. An exploding lead-acid battery can cause serious burns and injuries. Keep all flames including cigarettes and sparks away from lead-acid battery cells.

Do not jump-start a frozen lead-acid battery or one with a low fluid level.

Jump-starting a frozen lead-acid battery or one with a low fluid level is dangerous. It may rupture or explode, causing serious injury.

Connect the negative lead to a good ground point away from the lead-acid battery.

Connecting the end of the second jumper lead to the negative (-) terminal of the depleted lead-acid battery is dangerous.

A spark could cause the gas around the lead-acid battery to explode and injure someone.

Route the jumper leads away from parts that will be moving.

Connecting a jumper lead near or to moving part (cooling fans) is dangerous. The lead could get caught when the engine starts and cause serious injury.



- Use only a 12 V booster system. You can damage a 12 V starter, ignition system, and other electrical parts beyond repair with a 24 V power supply (two 12 V batteries in series).
- Do not use vehicles with Mazda M Hybrid Boost as a booster vehicle to prevent damaging your vehicle.

1. Make sure that the vehicle power is switched OFF.
2. Remove the hole cover.
Refer to Removing the hole cover in Inspecting Lead-acid battery on page 9-41.
3. Remove the lead-acid battery cover.

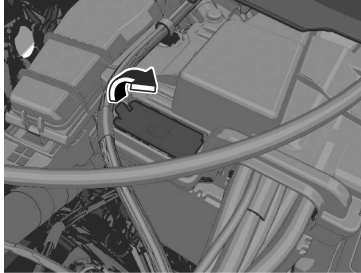

4. Turn off the booster vehicle's engine and connect the jumper leads in the following order.
Make sure that the jumper leads are securely connected so that they do not disconnect due to the vibrations.
1st lead
 - ① Positive (+) terminal on the depleted lead-acid battery
 - ② Positive (+) terminal on booster vehicle's battery**2nd lead**
 - ③ Negative (-) terminal on booster vehicle's battery
 - ④ Location shown in the figure (do not connect to the negative (-) terminal of the depleted lead-acid battery)

What to Do in Case of Emergency
Engine Does Not Start

Left-hand drive model

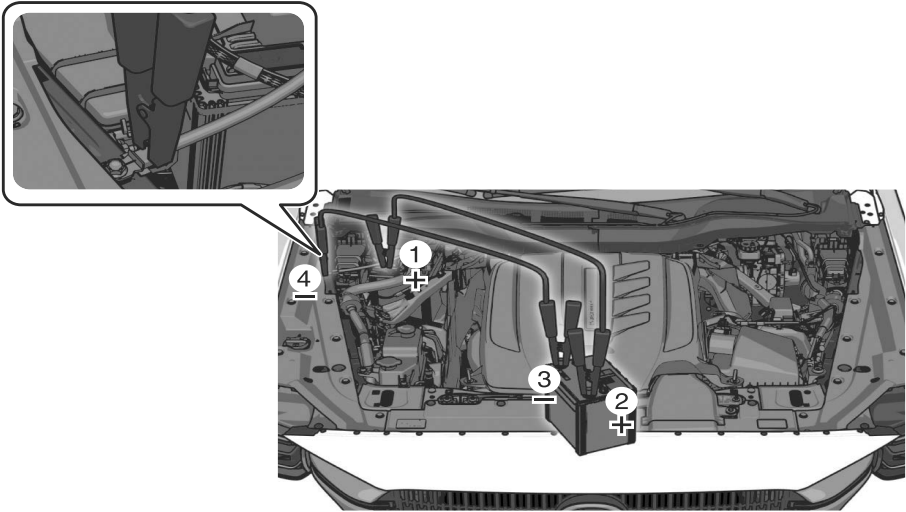

Right-hand drive model

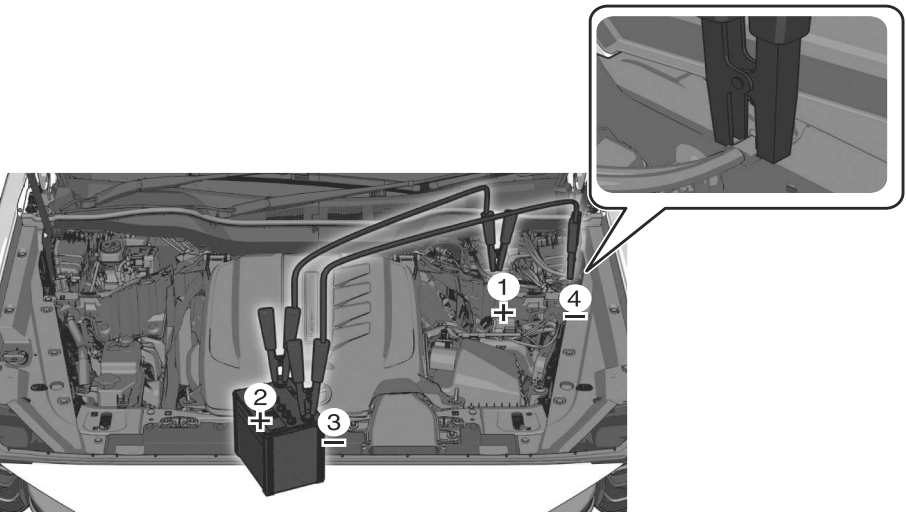

5. Start the booster vehicle's engine and rev the engine.
6. Start the engine of your vehicle.
7. Disconnect the booster leads in the reverse order of their connection after the engine is started.
8. Install the lead-acid battery cover.

9. Have your vehicle inspected by an expert repairer (we recommend an Authorised Mazda Repairer) as soon as possible.

Push-Starting

Do not push-start your Mazda.



Never tow a vehicle to start it.

Towing a vehicle to start it is dangerous. The vehicle being towed could surge forward when its engine starts, causing the 2 vehicles to collide. The occupants could be injured.

Starting a Flooded Engine

If the engine stops unexpectedly, it may be flooded (excessive fuel in the engine).

Follow this procedure:

1. If the engine does not start within 5 seconds on the first try, wait 10 seconds and try again.
2. Make sure the parking brake is on.
3. Depress the accelerator all the way and hold it there.
4. Depress the brake pedal, then press the push button start. If the engine starts, release the accelerator immediately because the engine will suddenly rev up.
5. If the engine fails to start, crank it without depressing the accelerator.

If the engine still does not start using the previous procedure, have your vehicle inspected by an expert repairer (we recommend an Authorised Mazda Repairer).

Forcibly Stopping the Engine

Press and hold the push button start or press it quickly and repeatedly. The engine stops and the vehicle power is switched ACC.

Applying the Emergency Brake

Continue pulling the EPB switch.

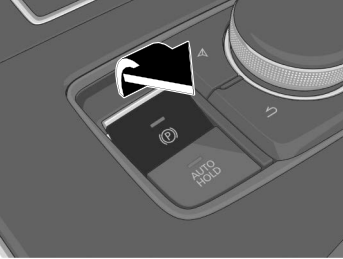

The brakes are applied and the vehicle can be decelerated/stopped. A sound is activated when the brake is applied and when the EPB switch is released, the brake will be released and the sound stops.

WARNING

Use only in emergency situations. Use this function only in an emergency. Excessive use will cause the brake parts to wear out quickly or cause the brakes to generate heat, reducing their effectiveness.

Forcibly Cancelling the AUTOHOLD

The AUTOHOLD can be cancelled forcibly by fully depressing the accelerator pedal for about 1 second while the AUTOHOLD is operating. Forcibly cancel the AUTOHOLD only when the AUTOHOLD cannot be cancelled due to a system malfunction or it is necessary to cancel the AUTOHOLD in an emergency.

Overheating

Taking Action with Overheating

If the engine coolant temperature gauge indicates overheating and the high engine coolant temperature warning light is displayed, the vehicle loses power or you hear a loud knocking or pinging noise, the engine is probably too hot.



Pull over to a safe location, then switch the vehicle power off and make sure the fan is not running before attempting to work near the cooling fan.

Working near the cooling fan when it is running is dangerous. The fan could continue running indefinitely even if the engine has stopped and the engine compartment temperature is high. You could be hit by the fan and seriously injured.



Do not remove either cooling system cap when the engine and radiator are hot.

When the engine and radiator are hot, scalding coolant and steam may shoot out under pressure and cause serious injury.

Open the bonnet ONLY after steam is no longer escaping from the engine.

Steam from an overheated engine is dangerous. The escaping steam could seriously burn you.

1. Drive safely to the side of the road and park off the right-of-way.
2. Shift into park (P).
3. Apply the parking brake.
4. Turn off the air conditioner.
5. Check whether coolant or steam is escaping from the engine compartment.

If steam is coming from the engine compartment:

Do not go near the front of the vehicle. Stop the engine.

Wait until the steam dissipates, then open the bonnet and start the engine.

If neither coolant nor steam is escaping:

Open the bonnet and idle the engine until it cools.



If the cooling fan does not operate while the engine is running, the engine temperature will increase. Stop the engine and call an expert repairer (we recommend an Authorised Mazda Repairer).

6. Make sure the cooling fan is operating, then turn off the engine after the temperature has decreased.
7. When cool, check the coolant level. If it is low, look for coolant leaks from the radiator and hoses.

If you find a leak or other damage, or if coolant is still leaking:

Stop the engine and call an expert repairer (we recommend an Authorised Mazda Repairer).

SKYACTIV-G

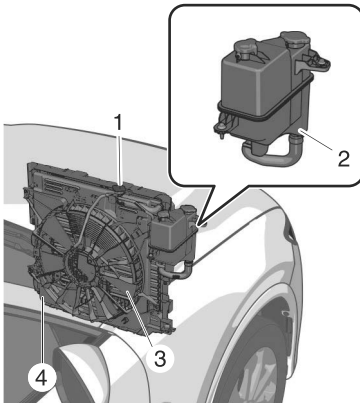

e-SKYACTIV G and e-SKYACTIV D

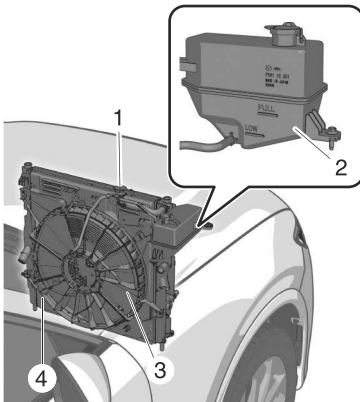

1. Cooling system cap
2. Coolant reservoir
3. Cooling fan
4. Radiator

If you find no problems, the engine is cool, and no leaks are obvious:

Carefully add coolant as required (page 9-37).

⚠ CAUTION

If the engine continues to overheat or frequently overheats, have the cooling system inspected. The engine could be seriously damaged unless repairs are made. Consult an expert repairer (we recommend an Authorised Mazda Repairer).

Using the Emergency Flat Tyre Repair Kit*

About the Emergency Flat Tyre Repair Kit

The emergency flat tyre repair kit included with your Mazda is for a temporary repair of a slightly damaged flat tyre resulting from running over nails or similar sharp objects on the road surface.

Perform the emergency flat tyre repair without removing the nail or similar sharp object which punctured the tyre.

WARNING

Do not allow children to touch the tyre sealant.

- Ingestion of tyre sealant is dangerous. In the event tyre sealant is accidentally swallowed, drink large amounts of water immediately and seek medical assistance.
- Tyre sealant that comes into contact with the eyes and skin is dangerous. If tyre sealant enters the eyes or contacts the skin, flush immediately with large amounts of water and seek medical assistance.

NOTE

- Your vehicle is not equipped with a spare tyre. In the event of a flat tyre, use the emergency flat tyre repair kit to repair the tyre temporarily. When doing the repair, refer to the instructions included in the emergency flat tyre repair kit. If an emergency repair was performed on a flat tyre using the emergency flat tyre repair kit, have an expert repairer (we recommend an Authorised Mazda Repairer), repair or replace the tyre as soon as possible.
- The tyre sealant cannot be reused. Purchase new tyre sealant at an expert repairer (we recommend an Authorised Mazda Repairer).
- The emergency flat tyre repair kit cannot be used in the following cases.
Consult an expert repairer (we recommend an Authorised Mazda Repairer).
 - The period of effective use for the tyre sealant has expired. (The period of effectiveness is indicated on the bottle label.)
 - The tear or puncture exceeds about 4 mm (0.16 in).
 - The damage has occurred to an area of the tyre other than the tread.
 - The vehicle has been driven with nearly no air remaining in the tyre.
 - The tyre has come off the wheel rim.
 - Damage to the wheel rim has occurred.

Tyre is Punctured or Bursts

- The tyre has 2 or more punctures.

The emergency flat tyre repair kit includes the following items.

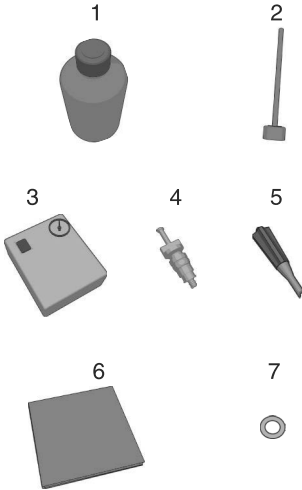

1. Tyre sealant
2. Injection hose
3. Compressor
4. Spare valve core
5. Valve core tool
6. Instructions
7. Speed restriction sticker

Using the Emergency Flat Tyre Repair Kit

1. Park on a level surface off the right-of-way and set the parking brake.
2. Put a vehicle in Park (P) and turn off the engine.
3. Turn on the hazard warning flasher.

4. Unload passengers and luggage, and remove the emergency flat tyre repair kit.

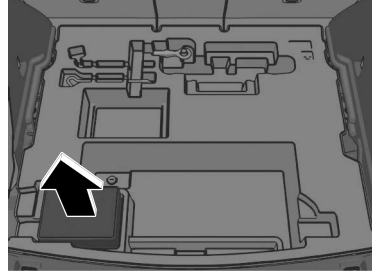

5. Shake the tyre sealant well.

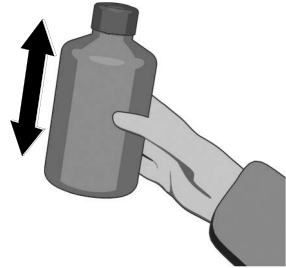

CAUTION

If the bottle is shaken after the injection hose is screwed on, tyre sealant could spray out from the injection hose. Tyre sealant contacting clothing or other objects may be impossible to remove. Shake the bottle before screwing on the injection hose.

NOTE

The tyre sealant can be used at outside temperatures down to -30°C (-22°F). In extremely cold temperatures (0°C (32°F) or below), the tyre sealant hardens easily and injection of the sealant will be difficult. Warm the sealant inside the vehicle before doing the injection work.

Tyre is Punctured or Bursts

6. Remove the cap from the bottle. Screw on the injection hose with the bottle's inner cap left on to break the inner cap.



7. Remove the valve cap from the flat tyre. Press the back of a valve core tool to the core of the tyre valve and bleed all the remaining air.

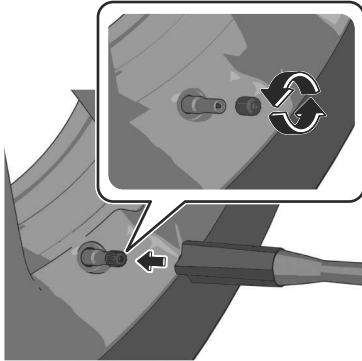

CAUTION

If there is air remaining in the tyre when the valve core is removed, the valve core could fly out. Remove the valve core carefully.

8. Turn the valve core anticlockwise with the valve core tool and remove the valve core.

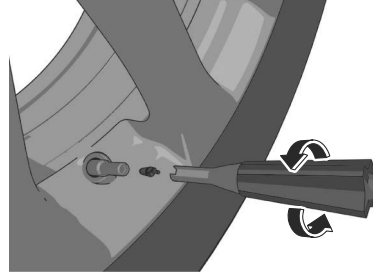

NOTE

Store the valve core in a place where it will not get dirty.

9. Insert the injection hose into the valve.

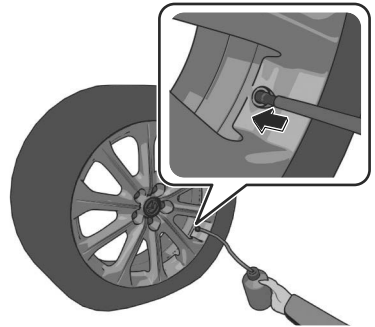

10. Hold the bottom of the bottle upright, squeeze the bottle with your hands, and inject the entire amount of tyre sealant into the tyre.

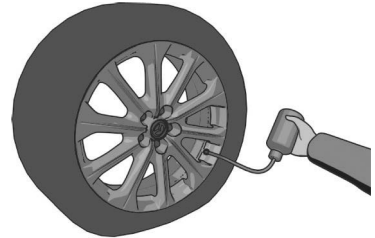

Tyre is Punctured or Bursts

11. Pull out the injection hose from the valve. Reinsert the valve core into the valve and turn it clockwise to install it.

NOTE

Do not throw away the empty tyre sealant bottle after use. Return the empty tyre sealant bottle to an expert repairer (we recommend an Authorised Mazda Repairer) when replacing the tyre. The empty tyre sealant bottle will need to be used to extract and dispose of the used sealant from the tyre.

12. Adhere the speed restriction sticker in a place where it can be viewed easily by the driver.

⚠ WARNING

Attach the speed restriction sticker in a place where it can be viewed easily by the driver.

Applying the speed restriction sticker to the steering wheel is dangerous as it could interfere with the air bag deployment and result in serious injury.

⚠ CAUTION

- Do not apply speed restriction stickers on the instrument panel or displays. Otherwise, the instrument panel or displays could be scratched or damaged when removing the sticker.
- Remove the speed restriction sticker immediately after repair or replacement of a tyre.

13. Install the compressor hose to the tyre valve.

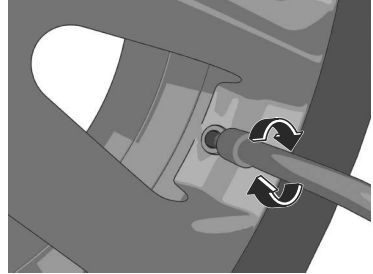

14. Insert the compressor plug into the interior accessory socket and switch the vehicle power to ACC (page 7-65).

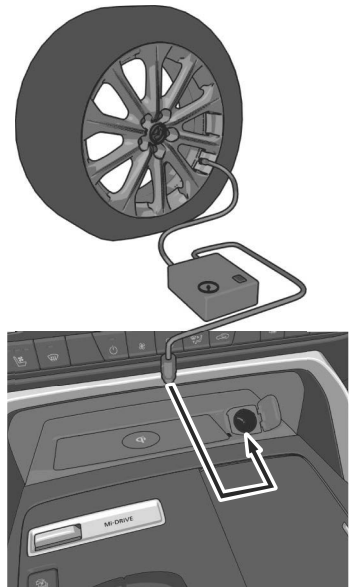

⚠ CAUTION

- Before pulling out the compressor plug from the electrical socket, make sure the compressor vehicle power is off.
- The compressor turns on and off with the push-button switch.

Tyre is Punctured or Bursts

15. Turn the compressor switch on and inflate the tyre carefully to the correct inflation pressure.



Never operate the compressor above 300 kPa (3.1 kgf/cm², 3 bar, 43.5 psi).

Operating the compressor above 300 kPa (3.1 kgf/cm², 3 bar, 43.5 psi) is dangerous. When the inflation pressure rises above 300 kPa (3.1 kgf/cm², 3 bar, 43.5 psi), heated air will be exhausted from the back of the compressor and you could be burned.

NOTE

- Check the tyre inflation pressure label (driver's door frame) for the correct tyre inflation pressure.
- Do not use the compressor for longer than 10 minutes because using the compressor for long periods could damage it.
- If the tyre does not inflate, repair of the tyre may not be possible. If the tyre does not reach the correct inflation pressure within a 10-minute period, it probably has received more extensive damage. When this happens, the emergency flat tyre repair kit cannot be used to repair the tyre. Contact an expert repairer (we recommend an Authorised Mazda Repairer).
- If the tyre has been over-inflated, loosen the screw cap on the compressor and bleed some of the air out.

16. When the tyre has been inflated to the proper inflation pressure, turn the compressor switch off and

remove the compressor hose from the tyre valve.

17. Install the tyre valve cap.
18. Put the emergency flat tyre repair kit in the luggage compartment and continue driving.



- Drive carefully to an expert repairer (we recommend an Authorised Mazda Repairer) and keep the vehicle speed below 80 km/h (50 mph).
- If the vehicle is driven 80 km/h (50 mph) or higher, the vehicle might begin to vibrate.

NOTE

If the tyre is not properly inflated, the tyre pressure monitoring system warning light (⚠) will illuminate (page 5-113).

19. After driving the vehicle for 10 minutes or 5 km (3 miles), check the tyre pressure with the tyre pressure gauge equipped with the compressor. If the tyre pressure has fallen below the correct tyre pressure, inflate the tyre to the correct pressure again following the steps from number 14.



- If the tyre inflation pressure falls below 130 kPa (1.3 kgf/cm² or bar, 18.9 psi), repair cannot be done with the repair kit. Park the vehicle on a level surface off the right-of-way and contact an expert repairer (we recommend an Authorised Mazda Repairer).

- If the tyre inflation pressure continues to remain low after repeating steps 13 to 20, park the vehicle on a level surface off the right-of-way and contact an expert repairer (we recommend an Authorised Mazda Repairer).

NOTE

When checking the tyre inflation pressure with the tyre pressure gauge on the compressor unit, make sure the compressor switch is turned off.

20. The emergency flat tyre repair is completed if the tyre air pressure does not decrease. Drive the vehicle carefully to the nearest expert repairer (we recommend an Authorised Mazda Repairer) promptly and have the tyre replaced. Mazda recommends that the tyre be replaced with a new one. If the tyre is to be repaired and reused, consult an expert repairer (we recommend an Authorised Mazda Repairer). Peel off the speed restriction sticker after replacing the tyre.

 **CAUTION**

- For a tyre which has undergone an emergency flat tyre repair using the emergency flat tyre repair kit, Mazda recommends that the tyre be replaced with a new one as soon as possible. If the tyre is to be repaired and reused, consult an expert repairer (we recommend an Authorised Mazda Repairer).
- The wheel can be reused after any sealant adhering to it is wiped off and carefully inspected. However, replace the tyre valve with a new one.

Changing a Flat Tyre (With Spare Tyre)*

NOTE

If the following occurs while driving, it could indicate a flat tyre.

- Steering becomes difficult.
- The vehicle begins to vibrate excessively.
- The vehicle pulls in one direction.

If you have a flat tyre, drive slowly to a level spot that is well off the road and out of the way of traffic to change the tyre.

Stopping in traffic or on the shoulder of a busy road is dangerous.

 **WARNING**

Do not install the temporary spare tyre on the rear wheels (driving wheels).

Driving with the temporary spare tyre on one of the rear driving wheels is dangerous. Handling will be affected. You could lose control of the vehicle, especially on ice or snow bound roads, and have an accident. Move a regular tyre to the rear wheel and install the temporary spare tyre to the front.

Be sure to follow the directions for changing a tyre.

Changing a tyre is dangerous if not done properly. The vehicle can slip off the jack and seriously injure someone. No person should place any portion of their body under a vehicle that is supported by a jack.

Tyre is Punctured or Bursts

Never allow anyone inside a vehicle supported by a jack.

Allowing someone to remain in a vehicle supported by a jack is dangerous. The occupant could cause the vehicle to fall resulting in serious injury.

NOTE

Make sure the jack is well lubricated before using it.

1. Park on a hard, level surface off the right-of-way and firmly set the parking brake.
2. Shift into Park (P) and turn off the engine.
3. Turn on the hazard warning flasher.
4. Have passengers get out of the vehicle and away from the vehicle and traffic.
5. Remove any luggage, the jack (page 7-92), spare tyre (page 7-92), and tools.

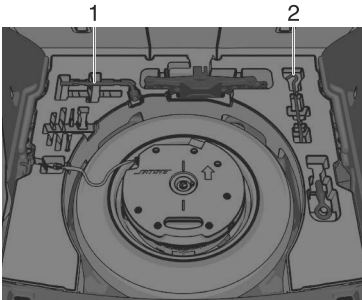

1. Wheel brace
2. Jack lever

6. Block the wheel diagonally opposite the flat tyre. When blocking a wheel, place a tyre block both in front and behind the tyre.

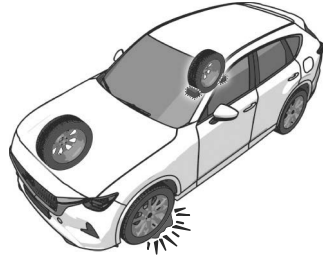

NOTE

When blocking a tyre, use rocks or wood blocks of sufficient size if possible to hold the tyre in place.

Removing a Flat Tyre

WARNING

When jacking-up a vehicle, always shift the selector lever to P position, apply the parking brake, and place wheel blocks in the position diagonally opposed to the jack.

Changing a flat tyre without using wheel blocks is dangerous because the vehicle may move and fall off the jack even with the selector lever in P position, which could result in an accident.

1. Loosen the wheel nuts by turning them anticlockwise one turn each, but do not remove any wheel nuts until the tyre has been raised off the ground.

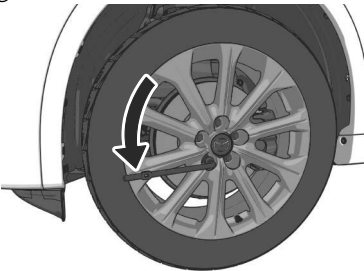

2. Place the jack on the ground.
3. Turn the jack screw in the direction shown in the figure and adjust the jack head so that it is close to the jack-up position.

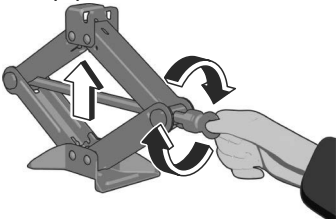

4. Place the jack under the jack-up position closest to the tyre being changed with the jack head squarely under the jack-up point.

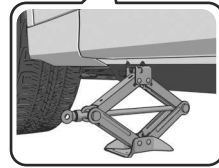

5. Continue raising the jack head gradually by rotating the screw with your hand until the jack head is inserted into the jack-up position.

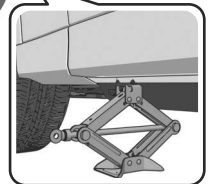
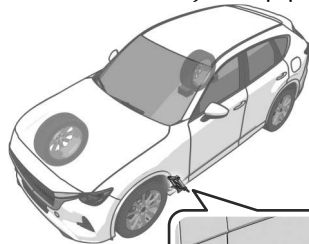

WARNING

Use only the front and rear jacking positions recommended in this manual.

Attempting to jack the vehicle in positions other than those recommended in this manual is dangerous. The vehicle could slip off the jack and seriously injure or even kill someone. Use only the front and rear jacking positions recommended in this manual.

Tyre is Punctured or Bursts

Do not jack up the vehicle in a position other than the designated jack-up position or place any objects on or under the jack.

Jacking up the vehicle in a position other than the designated jack-up position or placing objects on or under the jack is dangerous as it could deform the vehicle body or the vehicle could fall off the jack resulting in an accident.

Use only the jack provided with your Mazda.

Using a jack that is not designed for your Mazda is dangerous. The vehicle could slip off the jack and seriously injure someone.

Never place objects under the jack.

Jacking the vehicle with an object under the jack is dangerous. The jack could slip and someone could be seriously injured by the jack or the falling vehicle.

NOTE

When raising the jack head into the jacking position and aligning the groove in the jack head with the rail under the vehicle body, the top of the jack head contacts the vehicle's underbody without the rail contacting the bottom of the groove.

6. Insert the jack lever and attach the wheel brace to tyre jack.

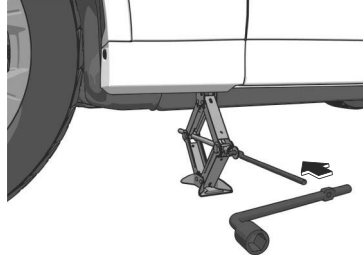

7. Turn the jack handle clockwise and raise the vehicle high enough so that the spare tyre can be installed. Before removing the wheel nuts, make sure your Mazda is firmly in position and that it cannot slip or move.

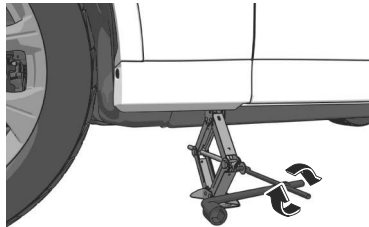

WARNING

Do not jack up the vehicle higher than is necessary.

Jacking up the vehicle higher than is necessary is dangerous as it could destabilize the vehicle resulting in an accident.

Do not start the engine or shake the vehicle while it is jacked up.

Starting the engine or shaking the vehicle while it is jacked up is dangerous as it could cause the vehicle to fall off the jack resulting in an accident.

Tyre is Punctured or Bursts

Never go under the vehicle while it is jacked up.

Going under the vehicle while it is jacked up is dangerous as it could result in death or serious injury if the vehicle were to fall off the jack.

8. Remove the wheel nuts by turning them anticlockwise; then remove the wheel and centre cap.

Mounting the Spare Tyre

1. Remove dirt and grime from the mounting surfaces of the wheel and hub, including the hub bolts, with a cloth.

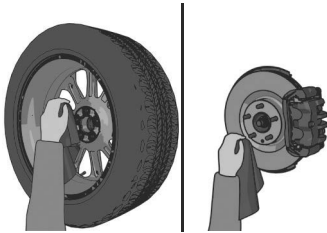

! WARNING

Make sure the mounting surfaces of the wheel, hub and wheel nuts are clean before changing or replacing tyres.

When changing or replacing a tyre, not removing dirt and grime from the mounting surfaces of the wheel, hub and hub bolts is dangerous. The wheel nuts could loosen while driving and cause the tyre to come off, resulting in an accident.

2. Mount the spare tyre.

3. Install the wheel nuts with the bevelled edge inward; tighten them by hand.

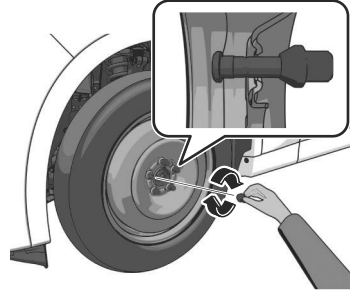

! WARNING

Do not apply oil or grease to wheel nuts and bolts and do not tighten the wheel nuts beyond the recommended tightening torque.

Applying oil or grease to wheel nuts and bolts is dangerous. The wheel nuts could loosen while driving and cause the tyre to come off, resulting in an accident. In addition, wheel nuts and bolts could be damaged if tightened more than necessary.

4. Turn the jack handle anticlockwise using the wheel brace and lower the vehicle.
5. Use the wheel brace to tighten the nuts in the order shown.

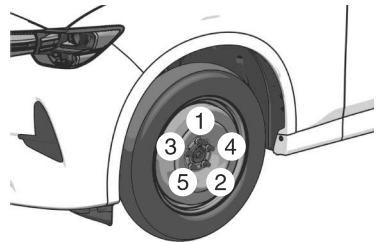

Tyre is Punctured or Bursts

If you are unsure of how tight the nuts should be, have them inspected at an expert repairer (we recommend an Authorised Mazda Repairer).

Nut tightening torque	
N·m (kgf·m, ft·lbf)	108—147 (12—14, 80—108)



Always securely and correctly tighten the wheel nuts.

Improperly or loosely tightened wheel nuts are dangerous. The wheel could wobble or come off. This could result in loss of vehicle control and cause a serious accident.

Be sure to reinstall the same nuts you removed or replace them with metric nuts of the same configuration.

Because the wheel studs and wheel nuts on your Mazda have metric threads, using a non-metric nut is dangerous. On a metric stud, it would not secure the wheel and would damage the stud, which could cause the wheel to slip off and cause an accident.

6. Remove the tyre blocks and store the tools and jack.
7. Store the damaged tyre in the luggage compartment.
8. Check the inflation pressure. Refer to Tyres on page 10-91.
9. Have the flat tyre repaired or replaced as soon as possible.

Open the liftgate from the luggage compartment

If the lead-acid battery is dead, the liftgate cannot be unlocked and opened. In this case, the liftgate can be unlocked by taking care of the dead lead-acid battery situation.

Refer to Taking Action with Depleted Lead-acid Battery on page 8-11.

If the liftgate cannot be unlocked even after charging the dead lead-acid battery, you can open the liftgate as an emergency measure by following the procedure below.

1. Fold down the rear seatbacks.
Refer to How to Use the Rear Seats on page 3-32.
2. Remove the cover.

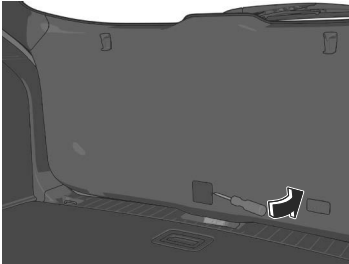

3. Move the lever.

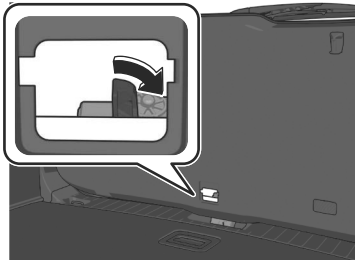

The liftgate is unlocked.

After performing this emergency measure, have the vehicle inspected by an expert repairer (we recommend an Authorised Mazda Repairer).

The Power Windows Cannot Be Operated

Initializing the Power Window

To restore these functions, do the following:

1. Switch the vehicle power ON.
2. Press the power window switch to fully open the window.
3. Pull the power window switch and fully close the window, and continue pulling the switch for about 2 seconds.

The Panorama Sunroof Cannot Be Operated

Initializing the Panorama Sunroof

If the panorama sunroof does not operate normally, do the following procedure.

1. Switch the vehicle power ON.
2. Press the tilt/slide switch forward to fully close the panorama sunroof and the sunshade.
3. Release the tilt/slide switch.
4. Press and hold the tilt/slide switch forward.
The panorama sunroof and sunshade move further in the close direction.
5. When the sunshade stops after about 13 seconds, release the tilt/slide switch.

Have the Vehicle Inspected

The windscreen wipers may operate at high speed if there is a problem with the wiper control.

If the wipers operate at high speed regardless of the wiper switch operation, have your vehicle inspected by an expert repairer (we recommend an Authorised Mazda Repairer).

Inspecting Washer Fluid Level

If the washer fluid is not sprayed, check the amount of fluid in the washer tank. Refer to Replenishing Windscreen Washer Fluid on page 9-40.

If air enters the washer pipe when refilling the empty washer tank with washer fluid, the washer fluid may not be sprayed.

Operate the wiper lever until the washer fluid is sprayed.

If the washer fluid is not sprayed even after refilling, consult an expert repairer (we recommend an Authorised Mazda Repairer).

Active Driving Display Does Not Operate

Active Driving Display Does Not Operate

If the active driving display does not operate, switch the vehicle power off and then restart the engine. If the active driving display does not operate even with the engine restarted, have the vehicle inspected at an expert repairer (we recommend an Authorised Mazda Repairer).

Warning/Indicator Light Turns On

Warning Lights

If any warning/indicator light turns on/flashes, take appropriate action for each light. If the warning/indicator light does not turn off, or it turns on or flashes again, consult an expert repairer (we recommend an Authorised Mazda Repairer).

WARNING

If the warning light/indicator light turns on or flashes, park the vehicle in a safe place immediately and take appropriate measures.

Continuing to drive the vehicle while ignoring the illumination/flashing of the warning light/indicator light is dangerous because a problem may occur to a vehicle system, the engine may be damaged, or it could lead to an accident.

The details for some warnings can be viewed on the centre display or instrument cluster.

Checking Using the Centre Display

1. Select "Information" on the home screen.
2. Select "Vehicle Status Monitor".
3. Select the applicable warning to view the warning details.

Checking Using the Instrument Cluster

Press the INFO switch on the steering switch to display the warning indication screen.

Instrument cluster (Type A)

Refer to How to Use the Instrument Cluster on page 5-27.

Instrument cluster (Type B)

Refer to How to Use the Multi-information Display on page 5-42.

Brake System Warning Light (Red)



The light turns on continuously if any one of the following occurs:

- Insufficient brake fluid
- Brake system (electronic brake force distribution system) has a problem

Park the vehicle in a safe place immediately and contact an expert repairer (we recommend an Authorised Mazda Repairer).

WARNING

Do not drive with the brake system warning light illuminated. Contact an expert repairer (we recommend an Authorised Mazda Repairer) to have the brakes inspected as soon as possible.

Driving with the brake system warning light illuminated is dangerous. It indicates that your brakes may not work at all or that they could completely fail at any time. If this light remains illuminated, after checking that the parking brake is fully released, have the brakes inspected immediately.

Warning/Indicator Light Turns On

If the brake system warning light and the ABS warning light  turn on at the same time, stop the vehicle in a safe place immediately and contact an expert repairer (we recommend an Authorised Mazda Repairer).

The rear wheels could lock more quickly in an emergency stop than under normal circumstances which could result in an accident.

CAUTION

- In addition, the effectiveness of the braking may diminish so you may need to depress the brake pedal more strongly than normal to stop the vehicle.
- (e-SKYACTIV G, e-SKYACTIV D)
The brake warning light may turn on when the engine is started. In this case, park the vehicle in a safe location and release the brake pedal. If the brake warning light remains illuminated, have the vehicle inspected by an expert repairer (we recommend an Authorised Mazda Repairer).

Charging System Warning Light



The light turns on if the charging system has a problem.

Park the vehicle in a safe place immediately and contact an expert repairer (we recommend an Authorised Mazda Repairer).

WARNING

Do not continue driving with the charging system warning light turned on:

Otherwise, the engine may stop, which could result in an accident.

Warning/Indicator Light Turns On

Hybrid System Warning Light*



The light turns on if the hybrid system has a problem. Contact an expert repairer (we recommend an Authorised Mazda Repairer).

Engine Oil Warning Light



The light turns on when the engine oil pressure decreases.

CAUTION

Do not drive the vehicle with the engine oil warning light turned on. Driving the vehicle with decreased engine oil pressure may cause engine damage.

If the engine oil warning light turns on while driving, stop the vehicle in a safe place and stop the engine. After that, contact an expert repairer (we recommend an Authorised Mazda Repairer).

Warning/Indicator Light Turns On

High Engine Coolant Temperature Warning Light



The light turns on if the engine coolant temperature has increased excessively. Check the contents of the message displayed and take the necessary action.



Do not drive the vehicle with the high engine coolant temperature warning light turned on. Driving the vehicle with the engine not cooled down may cause engine damage.

Electric Power Steering Warning Light



The warning light turns on if the electric power steering has a malfunction.

If the warning light turns on, stop the vehicle in a safe place and switch the vehicle power OFF.

There is no problem if the warning light turns off when the engine is restarted after some time has passed.

If the warning light turns on even after the engine is restarted, contact an expert repairer (we recommend an Authorised Mazda Repairer).

NOTE

- If the warning light turns on, the electric power steering will not operate normally. In this case, the steering wheel can still be operated, however, the operation may feel heavy compared to normal.
- Repeatedly jerking the steering wheel left and right while the vehicle is stopped or moving extremely slowly will cause the power steering system to go into protective mode which will make the steering feel heavy, but this does not indicate a problem. If this occurs, park the vehicle safely and do not operate the steering wheel. The system will return to normal after a few minutes.

Warning/Indicator Light Turns On

Shift System Warning Light



The light turns on if the shift system has a problem.

Park the vehicle in a safe place immediately and contact an expert repairer (we recommend an Authorised Mazda Repairer).

Always apply the parking brake when parking or stopping the vehicle, as it may not be possible to hold the vehicle in a stopped position even with the selector lever in the P position.

In addition, the engine may not start again if it is stopped.

ABS Warning Light



The light remains on if the system has a problem.

Have your vehicle inspected by an expert repairer (we recommend an Authorised Mazda Repairer).

WARNING

If the brake system warning light (red ) and the ABS warning light turn on at the same time, stop the vehicle in a safe place immediately and contact an expert repairer (we recommend an Authorised Mazda Repairer).

The rear wheels could lock more quickly in an emergency stop than under normal circumstances which could result in an accident.

Warning/Indicator Light Turns On

Master Warning Light



The light turns on if the system has a problem.

Check the contents of the message displayed on the centre display or in the instrument cluster and take the necessary action.

Brake Control System Warning Light (Amber)



The light turns on if the system has a problem.

Have your vehicle inspected by an expert repairer (we recommend an Authorised Mazda Repairer).

Warning/Indicator Light Turns On

Electric Parking Brake (EPB) Indicator Light



The light turns on when applying the parking brake and it turns off when releasing the parking brake.

Parking brake warning/Indicator light inspection

The light illuminates when the parking brake is applied with the vehicle power switched to START or ON. It turns off when the parking brake is released.

Turning on

If the light remains on even with the electric parking brake (EPB) switch turned off, the system may have a malfunction. Have the vehicle inspected by an expert repairer (we recommend an Authorised Mazda Repairer).

Flashing

The light flashes if the system has a problem. If the light remains flashing even if the electric parking brake (EPB) switch is pressed, consult an expert repairer (we recommend an Authorised Mazda Repairer) as soon as possible.

Check Engine Warning Light

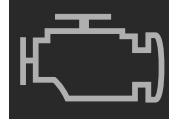

! WARNING

Do not disconnect the lead-acid battery leads when the check engine warning light is turned on/flashing.

The engine may be damaged when reconnecting the lead-acid battery leads, which could result in a fire.

The light turns on if the engine has a problem while it is running.

Park the vehicle in a safe place immediately and contact an expert repairer (we recommend an Authorised Mazda Repairer).

If any of the following problems occur, the check engine warning light turns on.

- There is a problem with the engine control system
- There is a problem with the emission control system
- There is a problem with the transmission control system
- **(e-SKYACTIV G, e-SKYACTIV D)**
There is a problem with the Mazda M Hybrid Boost
- **(SKYACTIV-G, e-SKYACTIV G)**
 - The fuel tank level being very low or approaching empty.

If the check engine warning light remains turned-on/flashing, do not drive at high speed and have the vehicle inspected by an expert repairer (we recommend an Authorised Mazda Repairer) as soon as possible.

Warning/Indicator Light Turns On

i-stop Warning Light (Amber)*



- After the engine is started, the light turns on/flashes continuously if the system has a problem.

Have the vehicle inspected by an expert repairer (we recommend an Authorised Mazda Repairer).

- **(Except European model)**

If the i-stop warning light (amber) remains on while the engine is running, the lead-acid battery performance may have decreased. Have your vehicle inspected at an expert repairer (we recommend an Authorised Mazda Repairer).

Petrol Particulate Filter Warning Light*



Check the contents of the message displayed and take the necessary action.



If the vehicle is continually driven as usual with the petrol particulate filter warning light illuminated, PM increases and the warning light may start flashing. If the petrol particulate filter warning light starts flashing, have the vehicle inspected immediately at an expert repairer (we recommend an Authorised Mazda Repairer). If the vehicle is not inspected and continues to be driven, the engine may malfunction.

Warning/Indicator Light Turns On

Diesel Particulate Filter Warning Light*



Check the contents of the message displayed and take the necessary action.



If the vehicle is continually driven as usual with the diesel particulate filter warning light turned on, PM increases and the warning light may start flashing. If the diesel particulate filter warning light starts flashing, have the vehicle inspected immediately at an expert repairer (we recommend an Authorised Mazda Repairer). If the vehicle is not inspected and continues to be driven, the engine may malfunction.

NOTE

When the diesel particulate filter warning light flashes, the engine output is restricted to protect the diesel particulate filter.

Automatic Transmission Warning Light



The light turns on if the system has a problem. Contact an expert repairer (we recommend an Authorised Mazda Repairer).



Do not drive the vehicle with the automatic transmission warning light turned on. If the vehicle continues to be driven while the automatic transmission warning light is turned on, the transmission could be damaged. Have your vehicle inspected by an expert repairer (we recommend an Authorised Mazda Repairer) as soon as possible.

Warning/Indicator Light Turns On

AWD Warning Light*



The light turns on if the system has a problem or if the tyre sizes do not match.

Check the contents of the message displayed and take the necessary action.

120 km/h Warning Light*



The light turns on when the vehicle speed exceeds 120 km/h.

In addition, when the light turns on, a warning sound is activated.

Lower the vehicle speed.

Warning/Indicator Light Turns On

Tyre Pressure Monitoring System (TPMS) Warning Light (Flashing)*



The light flashes if there is a malfunction in the system. Contact an expert repairer (we recommend an Authorised Mazda Repairer).

WARNING

Do not drive the vehicle at high speeds if the TPMS warning light turns on or flashes:

Driving the vehicle at high speeds while the TPMS warning light is turned on or flashing is dangerous because the brake performance and the steering wheel operability will be reduced. If the vehicle is driven at high speeds or the brakes are suddenly applied, it could lead to an accident. Gradually apply the brakes to lower the vehicle's speed.

Do not ignore the TPMS warning light when it is turned on or flashing:

Continuing to drive the vehicle while ignoring the illumination/flashing of the TPMS warning light is dangerous because a tyre may burst which could lead to an accident. Take appropriate measures as soon as possible.

TCS/DSC Indicator Light (Turns on)



There may be a problem with the DSC, TCS, or Hill Launch Assist (HLA) under the following conditions.

Have your vehicle inspected by an expert repairer (we recommend an Authorised Mazda Repairer).

- The light does not turn on or remains on even if the vehicle power is switched ON.
- It turns on while driving the vehicle.

Warning/Indicator Light Turns On

Air Bag/Seat Belt Pretensioner System Warning Light



A problem in the system might be indicated under the following conditions.

Have your vehicle inspected by an expert repairer (we recommend an Authorised Mazda Repairer).

- Does not turn on even if the vehicle power is switched ON.
- Remains turned-on/flashing.

WARNING

Never tamper with the air bag/pretensioner systems and always have an expert repairer (we recommend an Authorised Mazda Repairer) perform all servicing and repairs.

Self-servicing or tampering with the systems is dangerous. An air bag/pretensioner could accidentally activate or become disabled causing serious injury or death.

KEY Warning Light (Red)



The light turns on if the system has a problem or if the key is out of the operation range.

Check the contents of the message displayed and take the necessary action.

CAUTION

If the push button start indicator light (amber) flashes at the same time, the engine may not start. Have the vehicle inspected by an expert repairer (we recommend an Authorised Mazda Repairer) as soon as possible.

Warning/Indicator Light Turns On

Security Indicator Light



If the security indicator light turns on/ flashes while driving, do not stop the engine (leave it operating) and have the vehicle inspected at an expert repairer (we recommend an Authorised Mazda Repairer). If you stop the engine, you may not be able to start it again.

If the engine cannot be started, switch the vehicle power OFF, place the key in another position within the operation range, and then restart the engine. Check the security indicator light and if it does not turn off, such as it remains on or flashes, switch the vehicle power OFF, wait for a while, and then restart the engine.

If the engine does not start after three attempts, a system malfunction may have occurred. Have the vehicle inspected by an expert repairer (we recommend an Authorised Mazda Repairer).

NOTE

When repairing the immobilizer system, the key codes will need to be reprogrammed. Bring all the remaining keys to an expert repairer (we recommend an Authorised Mazda Repairer).

High Beam Control System (HBC) Warning Light (Amber)*



The light turns on if the system has a problem.

Have your vehicle inspected by an expert repairer (we recommend an Authorised Mazda Repairer).

Warning/Indicator Light Turns On

Adaptive LED Headlights (ALH) Warning Light (Amber)*



The light turns on if the system has a problem.
Have your vehicle inspected by an expert repairer (we recommend an Authorised Mazda Repairer).

i-ACTIVSENSE Warning Light



The light turns on if any i-ACTIVSENSE related system has a problem.
Check the contents of the message displayed and take the necessary action.

Warning/Indicator Light Turns On

Exterior Lights Warning Light



The light turns on if the exterior lights (not including the number plate lights) has a problem.

Have your vehicle inspected by an expert repairer (we recommend an Authorised Mazda Repairer).



Do not drive the vehicle while an exterior light has a malfunction. Poor visibility, and not being able to signal braking and turns may cause an accident. In addition, if the vehicle is driven with the lights not turned on, it may conflict with laws and regulations due to poor maintenance.

Low Fuel Warning Light



The light turns on/flashes when the remaining fuel in the tank is near empty.

When the light flashes, a warning sound is activated.

Refuel immediately.

NOTE

The light illumination timing may vary because fuel inside the fuel tank moves around according to the driving conditions and the vehicle posture.

Warning/Indicator Light Turns On

Engine Oil Level Warning Light



This warning light indicates that the engine oil level is around the MIN mark.



Do not continue to drive the vehicle with the engine oil level warning light turned on. If the vehicle continues to be driven with an insufficient amount of engine oil, it could cause damage to the engine.

Add 1 L (0.26 US gal, 0.22 Imp gal) of engine oil (page 9-33).

Seat Belt Warning Light (Front Seat)

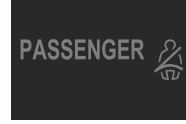

Turning on

The warning light turns on if the driver/front passenger's seat belt is not fastened when the vehicle power is switched ON.

Wear the seat belt.

Flashing

If the driver or passenger's seat belt is unfastened and the vehicle is driven at about 20 km/h or faster, the warning light flashes for a certain period.

After a short time, the warning light stops flashing, but remains illuminated. In addition, when the warning light flashes, a warning sound is activated. Wear the seat belt.

NOTE

- Placing heavy items on the front passenger's seat may cause the front passenger's seat belt warning function to operate depending on the weight of the item.
- To allow the sensor that detects an occupant to function properly, do not sit on the front passenger's seat with a cushion or other object on it. The sensor may not function properly because the additional seat cushion could cause sensor interference.
- If a small child is seated on the front passenger's seat, the warning light may not operate.

Warning/Indicator Light Turns On

Seat Belt Warning Light (Rear Seat) (Red)

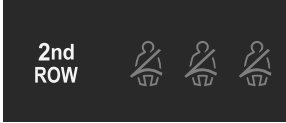

When the vehicle power is switched ON, the warning lights turn on if the seat belts are not fastened.*¹ After the engine is started, the warning lights turn off after a short period of time.

In addition, if a fastened seat belt is unfastened, the warning light flashes for a short period of time and then turns off.

When the warning light flashes, a warning sound is activated.

Wear the seat belt.

*¹ The warning light also turns on when the rear seat is unoccupied.

Low Washer Fluid Amount Warning Light*



The light turns on if the amount of washer fluid is low when the vehicle power is switched ON.

Add washer fluid.

Warning/Indicator Light Turns On

Selective Catalytic Reduction (SCR) Warning Light*



If the light turns on

The amount of AdBlue® is low or too much was added. Check the message indicated on the display and consult an expert repairer (we recommend an Authorised Mazda Repairer).

If the light is flashing

There is a problem with the SCR system or the remaining amount of AdBlue® is extremely low. Check the message indicated on the display and have the vehicle inspected by an expert repairer (we recommend an Authorised Mazda Repairer).



If the vehicle continues to be driven while the SCR warning light is flashing, the vehicle may stop running. If the SCR warning light flashes, have the vehicle inspected immediately at an expert repairer (we recommend an Authorised Mazda Repairer).

Door-ajar Warning Light/ Liftgate-open Warning Light/Bonnet-open Warning Light

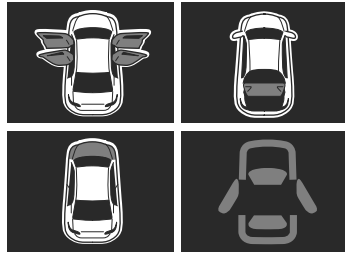

The light turns on if any door/liftgate/bonnet is not closed securely. Close the door/liftgate/bonnet securely.

Warning/Indicator Light Turns On

KEY Indicator Light (Green) (Flashing)



The light flashes if the battery power of the key is low when the vehicle power is switched from ON to OFF.
Replace the key battery.

Wrench Indicator Light

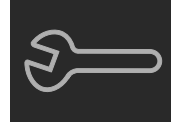

The wrench indication/indicator light is displayed/turns on under the following conditions.

- When the preset maintenance period has arrived.
Refer to the Information section in the Mazda Connect Owner's Manual.

CAUTION

- When the maintenance period arrives, have your vehicle inspected by an expert repairer (we recommend an Authorised Mazda Repairer) as soon as possible. If maintenance is neglected, a decrease in vehicle performance may occur which could cause damage. Have your vehicle inspected before the maintenance period arrives.
- If the vehicle continues to be driven after the engine oil replacement period has passed, it could cause damage to the engine. Replace the engine oil before the maintenance period arrives.

Warning/Indicator Light Turns On

➤ (e-SKYACTIV D)

Depending on the vehicle use conditions, engine oil replacement is required due to engine oil deterioration from fuel penetrating the engine oil. If “Excessive Oil Level. Have the Vehicle Inspected” is displayed on the multi-information display in the instrument cluster, have your vehicle inspected at an expert repairer (we recommend an Authorised Mazda Repairer).

· (e-SKYACTIV D)

- When fuel filter (sedimentor) draining is required. Consult an expert repairer (we recommend an Authorised Mazda Repairer).

NOTE

- The wrench indication/indicator light may display/turn on earlier than the preset period depending on vehicle usage conditions.
- Whenever the engine oil is replaced, a reset of the vehicle engine control unit is necessary. Refer to the Information section in the Mazda Connect Owner's Manual.

Lights-On Reminder

If the vehicle power is switched OFF with the exterior lights turned on and the driver's door is opened, a sound is activated.

Operate the headlight switch to turn off the exterior lights.

NOTE

A personalised function is available to change the sound volume for the lights-on reminder.

Refer to the Settings section in the Mazda Connect Owner's Manual.

Power Switch Not Switched OFF Reminder Warning Sound

European models

If the driver's door is opened with the vehicle power switched to ACC, a beep will be heard 6 times in the cabin to notify the driver that the vehicle power has not been switched OFF (STOP). Under this condition, the keyless entry system will not operate, the vehicle cannot be locked, and the lead-acid battery voltage will be depleted.

Except European models

If the driver's door is opened with the vehicle power switched to ACC, a beep will be heard continuously in the cabin to notify the driver that the vehicle power has not been switched OFF (STOP). Under this condition, the keyless entry system will not operate, the vehicle cannot be locked, and the lead-acid battery voltage will be depleted.

Switch the vehicle power OFF.

Warning Sound is Activated

Key Removed from Vehicle Warning Sound

Vehicles with advanced keyless function

If the key is taken out of the vehicle while the vehicle power is switched to ACC or ON, and all the doors are closed, a sound is activated 6 times outside of the vehicle and a sound is activated 1 time in the vehicle.

Vehicles without advanced keyless function

If the key is taken out of the vehicle while the vehicle power is switched to ACC or ON, and all the doors are closed, a sound is activated 1 time in the vehicle.

Make sure that you leave the vehicle while carrying the key, or switch the vehicle power OFF.

Key Left-in-Vehicle Warning Sound

If all the doors and luggage compartment are locked using another key while the key is left in the cabin, the beep which sounds outside of the vehicle will be heard for about 10 seconds to notify the driver that the key is in the cabin. In this case, take out the key by opening the door. A key taken out of the vehicle using this method may not operate because its functions have been temporarily stopped. To restore the key's functions, perform the applicable procedure (page 8-8).

Key Left-In-Luggage Compartment Warning Sound (Vehicles With Advanced Keyless Function)

If the key is left in the luggage compartment with all the doors locked and the liftgate closed, a beep will be heard outside for about 10 seconds to notify the driver that the key is in the luggage compartment. In this case, take out the key by pressing the electric liftgate opener and opening the liftgate.

The key taken out of the luggage compartment may not operate because its functions have been temporarily stopped. To restore the key's functions, perform the applicable procedure (page 8-8).

Door Lock Inoperable Warning Sound

Operation Using Touch Sensor

A warning beep is activated to notify the driver that the doors are not locked when all of the following conditions are met:

- The vehicle power is switched OFF.
- All the doors are not fully closed.
- The lock is operated 3 times within 5 seconds.

Check the vehicle power and whether the doors are open or closed, and then operate the lock again.

Operation Using Door-lock Switch on the Liftgate

When the door-lock switch on the liftgate is pressed under any of the following conditions, a warning sound is activated.

- The vehicle power is switched to a position other than OFF.
- Any door is open.

Make sure that none of the above conditions are present, and then press the door-lock switch again.

Warning Sound is Activated

Power Liftgate Warning Sound*

- A sound is activated 3 times when the power liftgate is operated and an object is stuck in the liftgate. Make sure that there is nothing stuck.
- If the vehicle is driven while the liftgate is open, a sound is activated for a while. Drive the vehicle with the liftgate closed.

Electronic Steering Lock Warning Sound

When the steering wheel is locked and you press the push button start, a warning sound is activated and the push button start indicator light (green) flashes.

Release the steering wheel by pressing the push button start while turning the steering wheel to the left and right.

Warning Sound is Activated

Brake System Warning Sound

A warning sound is activated if a problem with the brake system occurs and the brakes may not work as intended. Decelerate the vehicle while checking the safety of the surrounding area, and park the vehicle in a safe place. After stopping the vehicle, contact an expert repairer (we recommend an Authorised Mazda Repairer).

Brake Override Warning Sound

A warning sound is activated when the accelerator pedal and brake pedal are depressed at the same time while driving. Only depress the brake pedal.

Warning Sound is Activated

Electric Parking Brake (EPB) Warning Sound

The warning sound is activated under the following conditions:

- The vehicle is driven with the parking brake applied.
- The Electric Parking Brake (EPB) switch is pulled while the vehicle is driven.
- You attempt to start driving the vehicle while the conditions for releasing the Electric Parking Brake (EPB) automatically have not been met.

Check the condition of the parking brake.

Vehicle Problem Warning Sound

If any of the following problems occur, a warning sound is activated.

- Automatic transmission problem
- Increase in automatic transmission internal temperature
- Mazda M Hybrid Boost problem
- Brake system problem
- Electric Parking Brake (EPB) problem
- Engine oil pressure decrease
- Engine coolant temperature increase
- Engine system problem
- Shift control system problem
- Charging system problem

Check the information regarding the warning indication on the centre display or the instrument cluster.

Warning Sound is Activated

Shift Position Warning Sound

A warning sound is activated when the selector lever position and the shift position of the vehicle do not match. Check the selector lever position.

Selector Lever Not in P Reminder Warning Sound

A warning sound is activated if the following operations are performed while the selector lever is in a position other than P.

- The vehicle power is switched from ON to OFF.
- The driver's seat belt is unfastened and the driver's door is opened.

Check the selector lever position.

Warning Sound is Activated

Selective Catalytic Reduction (SCR) Warning Sound*

A sound is activated under the following conditions:

- There is a problem with the SCR system.
- The ignition is switched ON when the remaining amount of AdBlue® is extremely low.

If the sound is activated at the same time the SCR warning light turns on/ flashes, have your vehicle inspected by an expert repairer (we recommend an Authorised Mazda Repairer).

Reverse Position Warning Sound

The warning sound is activated when the vehicle power is switched ON and the selector lever is in the R position. If the selector lever is shifted to a position other than R, the warning sound stops.

Warning Sound is Activated

Door-Ajar Warning Sound

A warning sound is activated if the vehicle is driven with any door or liftgate ajar. Drive the vehicle after closing the doors and liftgate.

Low Lead-Acid Battery Charge Warning Sound

A warning sound is activated if the lead-acid battery charge is depleted. To charge the lead-acid battery, start the engine and keep running the engine for 5 minutes or longer.

If the Vehicle Becomes Stuck

What to do when the vehicle is stuck

WARNING

Do not spin the wheels at high speed, and do not allow anyone to stand behind a wheel when pushing the vehicle:

When the vehicle is stuck, spinning the wheels at high speed is dangerous. The spinning tyre could overheat and explode. This could cause serious injuries.

CAUTION

Too much rocking may cause engine overheating, transmission failure, and tyre damage.

If you must rock the vehicle to free it from snow, sand or mud, depress the accelerator slightly and slowly move the selector lever from D to R position.

Inspection and Servicing.....	9-4
Inspection and Servicing.....	9-4

Scheduled Maintenance.....	9-5
Scheduled Maintenance.....	9-5
Maintenance Table.....	9-6
Table 1.....	9-8
Table 2.....	9-12
Table 3.....	9-15
Table 4.....	9-17
Table 5.....	9-22

Daily Inspection.....	9-25
Daily Inspection.....	9-25
Warnings and Cautions for Daily Inspection.....	9-25

Engine Compartment Inspection.....	9-27
Checking the Inspection Locations and Inspection Items.....	9-27
Inspecting Engine Oil.....	9-33
Inspecting the Coolant.....	9-37
Inspecting the Brake Fluid.....	9-39
Replenishing Windscreen Washer Fluid.....	9-40
Inspecting Lead-acid Battery.....	9-41
Replacing the Fuses.....	9-44
Replenishing AdBlue® (With Selective Catalytic Reduction (SCR) System)*	9-45
Inspecting Body Lubrication.....	9-47

Vehicle Exterior Inspection.....	9-48
Checking the Inspection Locations and Inspection Items.....	9-48
Replacing Windscreen Wiper Blade Rubbers.....	9-48
Inspecting the Tyres.....	9-52
Rotating the Tyres.....	9-53
Replacing a Tyre or a Wheel.....	9-54
Inspecting the Emergency Flat Tyre Repair Kit.....	9-55
Replacing Light Bulbs.....	9-55

Vehicle Interior Inspection.....	9-56
Checking the Inspection Locations and Inspection Items.....	9-56
Air Conditioner Maintenance.....	9-57

Key Inspection.....	9-58
Warning And Caution about Key Replacement.....	9-58
Replacing the Key Battery.....	9-58

Exterior Maintenance.....	9-60
Exterior Maintenance.....	9-60
Wheel Maintenance.....	9-61

Interior Maintenance.....	9-62
Interior Maintenance.....	9-62
Instrument Panel Top (Soft pad) Maintenance.....	9-62

Upholstery and Synthetic Leather
Maintenance..... 9-63
Leather Upholstery
Maintenance..... 9-63

Maintenance of the Dust-proof
Sheet of the Active Driving
Display.....9-64
Seat Belt Maintenance..... 9-65

MEMO

Inspection and Servicing

Inspection and Servicing

Be careful not to hurt yourself when inspecting your vehicle, replacing a tyre, or doing some kind of maintenance such as car washing. In particular, wear thick work gloves such as cotton gloves when touching areas that are difficult to see while inspecting or working on your vehicle. Doing inspections or procedures with your bare hands could cause injury.

If you are unsure about any procedure this manual describes, we strongly urge you to have a reliable and qualified technician perform the work, consult an expert repairer (we recommend an Authorised Mazda Repairer).

Authorised Mazda technicians and genuine Mazda parts are dedicated to your vehicle. Without this expertise and the parts that have been designed and made especially for your Mazda, inadequate, incomplete, and insufficient servicing may result in problems. This could lead to vehicle damage or an accident and injuries.

For expert advice and quality service, consult an expert repairer (we recommend an Authorised Mazda Repairer).

The owner should retain evidence that proper maintenance has been performed as prescribed.

A claim against a warranty will not qualify if it results from lack of maintenance and not from defective material or authorised workmanship.

Scheduled Maintenance

NOTE

After the prescribed period, continue to follow the described maintenance at the recommended intervals.

Emission control and related systems

The ignition and fuel systems are highly important to the emission control system and to efficient engine operation. Do not tamper with them.

All inspections and adjustments must be made by an expert repairer (we recommend an Authorised Mazda Repairer).

Scheduled Maintenance

Maintenance Table

Each maintenance table is based on the environmental conditions for each country and region.

Perform the appropriate maintenance according to the maintenance table for your country or region.

For the maintenance table that applies to your country or region, refer to the following guide.

Country/Region Maintenance Table Guide

Country/Region	Maintenance Table	Country/Region	Maintenance Table	Country/Region	Maintenance Table
ALBANIA	1	ALGERIA	4	ANDORRA	1
ANGOLA	4	ANTIGUA	4	ARMENIA	2
ARUBA	4	AUSTRIA	1	AZERBAIJAN	2
B.VIRGIN	4	BAHRAIN	4	BARBADOS	4
BELARUS	2	BELGIUM	1	BERMUDA	4
BOLIVIA	4	BOSNIA AND HERZEGOVINA	1	BOTSWANA	4
BRUNEI	4	BULGARIA	1	BURUNDI	4
CAMBODIA	4	CAMEROON	4	CANARY ISLANDS	4
CHILE ^{*1}	4 or 5	COLOMBIA ^{*3}	4 or 6	COMMONWEALTH OF DOMINICA	4
COSTA RICA	4	CROATIA	1	CURACAO	4
CYPRUS ^{*2}	1 or 4	CZECH	1	DENMARK	1
DOMINICAN REPUBLIC (LHD)	4	ECUADOR	4	EGYPT	4
EL SALVADOR	4	ESTONIA	1	ETHIOPIA	4
F.GUIANA	4	FAEROE	4	FIJI	4
FINLAND	1	FRANCE	1	GABON	4
GEORGIA	4	GERMANY	1	GHANA	4
GREECE	1	GRENADA	4	GUADELOUPE	4
GUATEMALA	4	HAITI	4	HONDURAS	4
HONG KONG	4	HUNGARY	1	ICELAND	1
INDONESIA	4	IRAN	4	IRAQ	4
IRELAND	1	ISRAEL	3	ITALY	1
IVORY COAST	4	JAMAICA	4	JORDAN	4

Country/Region	Maintenance Table	Country/Region	Maintenance Table	Country/Region	Maintenance Table
KAZAKHSTAN	2	KENYA	4	KUWAIT	4
LAOS	4	LATVIA	1	LEBANON	4
LESOTHO	4	LIBYA	4	LIECHTENSTEIN	1
LITHUANIA	1	LUXEMBOURG	1	MACAU	4
MACEDONIA	1	MADAGASCAR	4	MALAYSIA ^{*3}	4 or 6
MALTA ^{*2}	1 or 4	MARSHALL ISLANDS	4	MARTINIQUE	4
MAURITIUS	4	MOLDOVA	1	MONACO	1
MONGOLIA	4	MONTENEGRO	1	MOROCCO	4
MOZAMBIQUE	4	MYANMAR	4	NAMIBIA	4
NEPAL	4	NEW CALEDONIA	4	NICARAGUA	4
NIGERIA	4	NORWAY	1	OMAN	4
PANAMA	4	PAPUA NEW GUINEA	4	PARAGUAY	4
PERU	4	POLAND	1	PORTUGAL	1
QATAR	4	REUNION	4	ROMANIA	1
RUSSIA	2	SAN MARINO	1	SAUDI ARABIA ^{*1}	4 or 5
SENEGAL	4	SERBIA	1	SEYCHELLES	4
SINGAPORE ^{*3}	4 or 6	SLOVAKIA	1	SLOVENIA	1
SOUTH AFRICA	4	SPAIN	1	SRI LANKA	4
ST.LUCIA	4	ST.MARTIN	4	ST.VINCENT	4
SURINAM	4	SWAZILAND	4	SWEDEN	1
SWITZERLAND	1	SYRIA	4	TAHITI	4
TAIWAN	4	TANZANIA	4	THAILAND	4
THE NETHERLANDS	1	THE PHILIPPINES	4	TRINIDAD AND TOBAGO	4
TUNISIA	4	TURKEY	4	UAE	4
UK	1	UKRAINE	1	URUGUAY	4
USTT	4	VANUATU	4	VATICAN	1
VIETNAM	4	ZIMBABWE	4	Country/Region, not listed in the chart	4

^{*1} Table 4: Diesel engine and SKYACTIV-G 2.5T, Table 5: Petrol engine except SKYACTIV-G 2.5T

^{*2} Table 1: Petrol engine and e-SKYACTIV EV, Table 4: Diesel engine

^{*3} Table 4: Except e-SKYACTIV EV, Table 6: e-SKYACTIV EV

Table 1

Vehicles utilizing the vehicle status monitor feature (My Mazda Service):

The vehicle status monitor feature alerts you of maintenance needs by turning on the wrench indicator light or displaying a message in the instrument panel, or both.

Every maintenance must be done when the display/wrench indication comes on. The display/wrench indication will come on before reaching the maximum interval, 20,000 km (12,500 miles) or 12 months, whichever comes first. (after the previous maintenance)

Maintenance item		Number of times, maintenance was performed.												
		1	2	3	4	5	6	7	8	9	10	11	12	
SKYACTIV-G and e-SKYACTIV G														
Engine oil & filter*1*2		R	R	R	R	R	R	R	R	R	R	R	R	R
Spark plugs*4	SKYACTIV-G	Replace every 120,000 km (75,000 miles).												
	e-SKYACTIV G	Replace every 64,000 km (40,000 miles).												
Air filter*5				R			R			R			R	
Fuel filter	Cyprus/ Malta	Replace every 60,000 km (37,500 miles).												
Hoses and tubes for emission				I			I			I			I	
Self-test with Mazda Modular Diagnostic System (M-MDS)*6*7 SKYACTIV-G, e-SKYACTIV G and e-SKYACTIV X	Ukraine	I	I	I	I	I	I	I	I	I	I	I	I	
e-SKYACTIV D														
Engine oil & filter*1*2*3		R	R	R	R	R	R	R	R	R	R	R	R	R
Air filter*5		C	C	R	C	C	R	C	C	R	C	C	R	
Fuel filter				R			R			R			R	
Urea solution (AdBlue®) for SCR system		*8	*8	*8	*9	*8	*8	*8	*9	*8	*8	*8	*9	
Check DTCs stored in emissions-related modules*10	e-SKYACTIV D	I	I	I	I	I	I	I	I	I	I	I	I	
SKYACTIV-G, e-SKYACTIV G AND e-SKYACTIV D														
Drive belts*11				I			I			I			I	
Fuel lines and hoses			I		I		I		I		I		I	
Vacuum brake booster and hose	With vacuum booster		I		I		I		I		I		I	
Exhaust system and heat shields		Inspect every 100,000 km (62,500 miles) or 8 years.												

Maintenance item		Number of times, maintenance was performed.											
		1	2	3	4	5	6	7	8	9	10	11	12
Coolant level		I	I	I	I	I	I	I	I	I	I	I	I
Coolant* ¹²		Replace at first 200,000 km (125,000 miles) or 10 years; after that, every 100,000 km (62,500 miles) or 5 years.											
Battery* ¹³ * ¹⁴		I	I	I	I	I	I	I	I	I	I	I	I
Brake lines, hoses and connections		I	I	I	I	I	I	I	I	I	I	I	I
Brake fluid* ¹⁵			R		R		R		R		R		R
Disc brakes		I	I	I	I	I	I	I	I	I	I	I	I
Steering operation and link-ages	Except below		I		I		I		I		I		I
	Cyprus/ Malta	I	I	I	I	I	I	I	I	I	I	I	I
Front and rear suspension, ball joints and wheel bearing axial play			I		I		I		I		I		I
Driveshaft dust boots			I		I		I		I		I		I
Bolts and nuts on chassis and body			T		T		T		T		T		T
Body condition (for rust, corrosion and perforation)		Inspect annually.											
Cabin air filter (if equipped)			R		R		R		R		R		R
Tyre inflation pressure and tyre wear* ¹⁶ * ¹⁷		I	I	I	I	I	I	I	I	I	I	I	I
Emergency flat tyre repair kit (if equipped)* ¹⁸		I	I	I	I	I	I	I	I	I	I	I	I

Chart symbols:

I: Inspect: Inspect and clean, repair, adjust, fill up, or replace if necessary.

C: Clean

T: Tighten

R: Replace

Remarks:

*1 Reset the engine oil data whenever replacing the engine oil regardless of the message/wrench indicator light display.

- *2 Except Diesel engine in Ukraine, if you drive your vehicle under any of the following conditions, replace the engine oil & filter every 10,000 km (6,250 miles) or shorter.
- a) The vehicle is idled for long periods or driven at low speeds, such as with police cars, taxis, or driver's education school car.
 - b) Driving under dusty conditions.
 - c) Driving for long periods in cold temperatures or driving regularly for short distances only.
 - d) Driving under extremely high temperature conditions.
 - e) Driving continuously in mountainous regions.

Scheduled Maintenance

- *3 For Diesel engine in Ukraine, if you drive your vehicle under any of the following conditions, replace the engine oil & filter every 5,000 km (3,125 miles) or shorter.
 - a) The vehicle is idled for long periods or driven at low speeds, such as with police cars, taxis, or driver's education school car.
 - b) Driving under dusty conditions.
 - c) Driving for long periods in cold temperatures or driving regularly for short distances only.
 - d) Driving under extremely high temperature conditions.
 - e) Driving continuously in mountainous regions.
- *4 In the countries below, inspect the spark plugs at every 10,000 km (6,250 miles) or 12 months before replacing them at the said interval.
Albania, Bosnia and Herzegovina, Bulgaria, Croatia, Latvia, Macedonia, Moldova, Montenegro, Romania, Serbia, Slovakia, Ukraine
- *5 If the vehicle is operated in very dusty or sandy areas, clean and if necessary, replace the air filter more often than the recommended intervals.
- *6 If DTC P1200 is stored, clean the fuel system by using Mazda genuine deposit cleaner.
If the required tool (M-MDS) is not available, clean the fuel system by using Mazda genuine deposit cleaner without performing self-test.
Using non-genuine deposit cleaner could cause internal damage to the fuel system.
- *7 If the vehicle is operated primarily under any of the following conditions, perform "Self-test with Mazda Modular Diagnostic System (M-MDS)" at every 10,000 km (6,250 miles).
 - a) The vehicle is idled for long periods or driven at low speeds, such as with police cars, taxis, or driver's education school car.
 - b) Driving under extremely high temperature conditions.
- *8 Top up with new AdBlue® in the urea tank.
- *9 If more than 10,000 km are driven per year, top up with new AdBlue® in the tank.
If less than 10,000 km are driven per year, drain the tank, then fill it up with new AdBlue®.
- *10 If any DTCs are stored, repair malfunction location according to applicable DTC troubleshooting.
- *11 Also inspect the air conditioner drive belts, if equipped.
If the vehicle is operated primarily under any of the following conditions, inspect the drive belts at every 20,000 km (12,500 miles) or 12 months.
 - a) Driving under dusty conditions.
 - b) The vehicle is idled for long periods or driven at low speeds.
 - c) Driving for long periods in cold temperatures or driving regularly for short distances only.
 - d) Driving under extremely high temperature conditions.
 - e) Driving continuously in mountainous regions.
 - f) Driving for long period in extremely wet or heavy rain condition.
- *12 Use of FL-22 is recommended when replacing coolant. Using coolant other than FL-22 may cause serious damage to the engine and cooling system.
- *13 Inspect the battery electrolyte level and outer appearance. The sealed battery only requires an outer appearance inspection.
- *14 Inspection is only subjected for lead-acid battery.
- *15 If the brakes are used extensively (for example, continuous hard driving or mountain driving) or if the vehicle is operated in extremely humid climates, replace the brake fluid annually.
- *16 Tyre rotation is recommended every 10,000 km (6,250 miles).
- *17 Inspect a spare tyre if equipped.

- *18 Check the tyre repair fluid expiration date every year when performing the periodic maintenance.
Replace the tyre repair fluid bottle with new one before the expiration date.

Table 2

Vehicles utilizing the vehicle status monitor feature:

The vehicle status monitor feature alerts you of maintenance needs by turning on the wrench indicator light or displaying a message in the instrument panel, or both. Every maintenance must be done when the display/wrench indication comes on. The display/wrench indication will come on before reaching the maximum interval in travelled distance or elapsed days since the last maintenance, or if the engine oil has deteriorated. Depending on driving manner and/or conditions, engine oil may deteriorate before reaching the maximum interval.

Russia/Belarus/Kazakhstan

Maximum interval 15,000 km or 12 months, whichever comes first.

Azerbaijan/Armenia

Maximum interval 10,000 km or 12 months, whichever comes first.

Manually set Next Service Distance of Vehicle Status Monitor to a half mileage from the above maximum mileage and months i.e. 7,500 km/ 6 months at Russia/Belarus/Kazakhstan or 5,000 km/ 6 months at Azerbaijan/Armenia if the vehicle is driven primarily under any of the following conditions:

Refer to the Information section in the Mazda Connect Owner's Manual about the manual setting procedure.

1. The vehicle is idled for long periods or driven at low speeds, such as with police cars, taxis, or driver's education school car.
2. Driving under dusty conditions.
3. Driving for long periods in cold temperatures or regularly driving too short distances for engine warm-up to be completed.
4. Driving under extremely high temperature conditions.
5. Driving continuously in mountainous regions.

Maintenance item		Number of times, maintenance was performed.											
		1	2	3	4	5	6	7	8	9	10	11	12
Engine oil & filter*1		R	R	R	R	R	R	R	R	R	R	R	R
Spark plugs	SKYACTIV-G	I	I	I	I	I	I	I	R	I	I	I	I
	e-SKYACTIV G	I	I	I	R	I	I	I	R	I	I	I	R
Drive belts*2		I	I	I	I	I	I	I	I	I	I	I	I
Coolant level		I	I	I	I	I	I	I	I	I	I	I	I
Battery*3*4		I	I	I	I	I	I	I	I	I	I	I	I
Vacuum brake booster and hose	With vacuum booster		I		I		I		I		I		I
Brake lines, hoses and connections		I	I	I	I	I	I	I	I	I	I	I	I

Maintenance item	Number of times, maintenance was performed.											
	1	2	3	4	5	6	7	8	9	10	11	12
Disc brakes	I	I	I	I	I	I	I	I	I	I	I	I
Steering operation and linkages	I	I	I	I	I	I	I	I	I	I	I	I
Bolts and nuts on chassis and body	T	T	T	T	T	T	T	T	T	T	T	T
Front and rear suspension, ball joints and wheel bearing axial play	I	I	I	I	I	I	I	I	I	I	I	I
Driveshaft dust boot	I	I	I	I	I	I	I	I	I	I	I	I
Exhaust system and heat shields	I	I	I	I	I	I	I	I	I	I	I	I
Function of all lights	I	I	I	I	I	I	I	I	I	I	I	I
Body condition (for rust, corrosion and perforation)	I	I	I	I	I	I	I	I	I	I	I	I
Tyre inflation pressure and tyre wear ^{*5*6}	I	I	I	I	I	I	I	I	I	I	I	I
Emergency flat tyre repair kit (if equipped) ^{*7}	I	I	I	I	I	I	I	I	I	I	I	I
Fuel lines & hoses		I		I		I		I		I		I
Brake fluid ^{*8}		R		R		R		R		R		R
Cabin air filter (if equipped)		R		R		R		R		R		R
Hoses and tubes for emission				I				I				I
Air filter ^{*9}			R			R			R			R
Fuel filter	Except below countries		Replace every 120,000 km.									
	Azerbaijan/ Armenia		Replace every 60,000 km.									
Coolant ^{*10}		Replace at first 195,000 km or 120 months; after that, every 90,000 km or 60 months.										

Chart symbols:

I: Inspect and clean, repair, adjust, fill up, or replace if necessary.

T: Tighten

R: Replace

Remarks:

- ^{*1} Reset the engine oil data whenever replacing the engine oil regardless of the message/wrench indicator light display.
- ^{*2} Also inspect the air conditioner drive belts, if equipped.
If the vehicle is driven primarily under any of the following conditions, inspect the drive belts at every 7,500 km or 6 months.
 - a) Driving for long period in extremely wet or heavy rain condition.
- ^{*3} Inspect the battery electrolyte level and outer appearance. The sealed battery only requires an outer appearance inspection.

Scheduled Maintenance

- *4 Inspection is only subjected for lead-acid battery.
- *5 Tyre rotation is recommended every 15,000 km.
- *6 Inspect a spare tyre if equipped.
- *7 Check the tyre repair fluid expiration date every year when performing the periodic maintenance. Replace the tyre repair fluid bottle with new one before the expiration date.
- *8 If the brakes are used extensively (for example, continuous hard driving or mountain driving) or if the vehicle is operated in extremely humid climates, replace the brake fluid annually.
- *9 If the vehicle is operated in very dusty or sandy areas, clean and if necessary, replace the air filter more often than the recommended intervals.
- *10 Use of FL-22 is recommended when replacing coolant. Using coolant other than FL-22 may cause serious damage to the engine and cooling system.

Table 3

Vehicles utilizing the vehicle status monitor feature:

The vehicle status monitor feature alerts you of maintenance needs by turning on the wrench indicator light or displaying a message in the instrument panel, or both. Every maintenance must be done when the display/wrench indication comes on. The display/wrench indication will come on before reaching the maximum interval.

Maximum interval 15,000 km or 12 months, whichever comes first

Manually set Next Service Distance of Vehicle Status Monitor to 10,000 km or shorter if the vehicle is driven primarily under any of the following conditions: Refer to the Information section in the Mazda Connect Owner's Manual about the manual setting procedure.

1. The vehicle is idled for long periods or driven at low speeds, such as with police cars, taxis, or driver's education school car.
2. Driving under dusty conditions.
3. Driving for long periods in cold temperatures or driving regularly for short distances only.
4. Driving under extremely high temperature conditions.
5. Driving continuously in mountainous regions.

Maintenance Item		Number of times, maintenance was performed.											
		1	2	3	4	5	6	7	8	9	10	11	12
Engine oil & oil filter* ¹		R	R	R	R	R	R	R	R	R	R	R	R
Drive belts* ²		I	I	I	I	I	I	I	I	I	I	I	I
Coolant level		I	I	I	I	I	I	I	I	I	I	I	I
Battery* ³ ⁴		I	I	I	I	I	I	I	I	I	I	I	I
Vacuum brake booster and hose	With vacuum booster	I	I	I	I	I	I	I	I	I	I	I	I
Brake and clutch fluid level		I	I	I	I	I	I	I	I	I	I	I	I
Brake lines, hoses and connections		I	I	I	I	I	I	I	I	I	I	I	I
Disc brakes		I	I	I	I	I	I	I	I	I	I	I	I
Bolts and nuts on chassis and body		T	T	T	T	T	T	T	T	T	T	T	T
Front and rear suspension, ball joints and wheel bearing axial play		I	I	I	I	I	I	I	I	I	I	I	I
Body condition (for rust, corrosion and perforation)		I	I	I	I	I	I	I	I	I	I	I	I
Tyre inflation pressure and tyre wear* ⁵		I	I	I	I	I	I	I	I	I	I	I	I
Emergency flat tyre repair kit (if equipped)* ⁶		I	I	I	I	I	I	I	I	I	I	I	I
Fuel lines and hoses			I		I		I		I		I		I

Inspection and Servicing/Cleaning
Scheduled Maintenance

Maintenance Item	Number of times, maintenance was performed.											
	1	2	3	4	5	6	7	8	9	10	11	12
Steering operation and linkages		I		I		I		I		I		I
Brake fluid*7		R		R		R		R		R		R
Cabin air filter (if equipped)		R		R		R		R		R		R
Hoses and tubes for emission				I				I				I
Driveshaft dust boots			I			I			I			I
Air filter*8				R				R				R
Exhaust system and heat shields					I					I		
Spark plugs	Replace every 120,000 km.											
Fuel filter	Replace every 135,000 km.											
Coolant*9	Replace at first 195,000 km or 10 years; after that, every 90,000 km or 5 years.											

Chart symbols:

I: Inspect: Inspect and clean, repair, adjust, fill up, or replace if necessary.

T: Tighten

R: Replace

Remarks:

- *1 Reset the engine oil data whenever replacing the engine oil regardless of the message/wrench indicator light display.
- *2 Also inspect the air conditioner drive belts, if equipped.
If the vehicle is driven primarily under any of the following conditions, inspect the drive belts at every 10,000 km or shorter.
 - a) Driving for long period in extremely wet or heavy rain condition.
- *3 Inspect the battery electrolyte level and outer appearance. The sealed battery only requires an outer appearance inspection.
- *4 Inspection is only subjected for lead-acid battery.
- *5 Inspect a spare tyre if equipped.
- *6 Check the tyre repair fluid expiration date every year when performing the periodic maintenance.
Replace the tyre repair fluid bottle with new one before the expiration date.
- *7 If the brakes are used extensively (for example, continuous hard driving or mountain driving) or if the vehicle is operated in extremely humid climates, replace the brake fluid annually.
- *8 If the vehicle is driven in very dusty or sandy areas, clean and if necessary, replace the air filter more often than the recommended intervals.
- *9 Use of FL-22 is recommended when replacing coolant. Using coolant other than FL-22 may cause serious damage to the engine and cooling system.

Table 4

Vehicles utilizing the vehicle status monitor feature

The vehicle status monitor feature alerts you of maintenance needs by turning on the wrench indicator light or displaying a message in the instrument panel, or both. Every maintenance must be done when the display/wrench indication comes on. The display/wrench indication will come on before reaching the maximum interval.

For Vehicles in Burundi, Cambodia, Cameroon, Gabon, Georgia, Ghana, Mongolia, Mozambique, Paraguay, Tanzania and for Diesel engine in Philippines.

Maximum interval 5,000 km (3,125 miles) or 6 months, whichever comes first.

For Vehicles in applicable countries/regions, except Burundi, Cambodia, Cameroon, Gabon, Georgia, Ghana, Mongolia, Mozambique, Paraguay, Tanzania, for Diesel engine vehicles in Philippines and for Petrol engine vehicles in South Africa.

Maximum interval 10,000 km (6,250 miles) or 6 months, whichever comes first.

For Petrol engine vehicles in South Africa.

Maximum interval 15,000 km (9,375 miles) or 12 months, whichever comes first.

Manually set Next Service Distance of Vehicle Status Monitor to a shorter mileage than maximum interval (50 % of maximum mileage is recommended) if the vehicle is driven primarily under any of the following conditions: Refer to the information section in the Mazda Connect Owner's Manual about the manual setting procedure.

1. The vehicle is idled for long periods or driven at low speeds, such as with police cars, taxis, or driver's education school car.
2. Driving under dusty conditions.
3. Driving for long periods in cold temperatures or driving regularly for short distances only.
4. Driving under extremely high temperature conditions.
5. Driving continuously in mountainous regions.

Maintenance item		Number of times, maintenance was performed.															
		1	2	3	4	5	6	7	8	9	10	11	12	13	14	15	16
SKYACTIV-G AND e-SKYACTIV G																	
Engine oil & filter ^{*1}		R	R	R	R	R	R	R	R	R	R	R	R	R	R	R	R
Air filter ^{*2}	Except South Africa						R					R					
	South Africa			R			R			R			R			R	
Fuel filter	Except Taiwan	Replace every 60,000 km (37,500 miles).															
	Taiwan	Replace every 80,000 km (50,000 miles).															

Inspection and Servicing/Cleaning
Scheduled Maintenance

Maintenance item		Number of times, maintenance was performed.															
		1	2	3	4	5	6	7	8	9	10	11	12	13	14	15	16
Spark plugs* ³	SKYACTIV-G	Replace every 120,000 km (75,000 miles).															
	e-SKYACTIV G	Replace every 64,000 km (40,000 miles).															
Self-test with Mazda Modular Diagnostic System (M-MDS)* ⁴ ⁵ ⁶ SKYACTIV-G, e-SKYACTIV G & e-SKYACTIV X	Except below countries																
	Burundi/ Cambodia/ Cameroon/ Gabon/ Ghana/ Mongolia/ Paraguay/ Tanzania																
e-SKYACTIV D																	
Engine oil* ¹		R	R	R	R	R	R	R	R	R	R	R	R	R	R	R	R
Engine oil filter	Except below countries	R	R	R	R	R	R	R	R	R	R	R	R	R	R	R	R
	Philippines		R	R		R		R		R		R		R		R	
Air filter* ²			C		C		R		C		C		R		C		C
Fuel filter					R				R				R				R
Urea solution (AdBlue®) for SCR system (if equipped)			* ⁷		* ⁷		* ⁷		* ⁸		* ⁷		* ⁷		* ⁷		* ⁸
Self-test with Mazda Modular Diagnostic System (M-MDS)* ⁹	e-SKYACTIV D																
SKYACTIV-G, e-SKYACTIV G AND e-SKYACTIV D																	
Drive belts* ¹⁰																	
Fuel lines and hoses																	
Vacuum brake booster and hose	With vacuum booster																
Hoses and tubes for emission																	
Exhaust system and heat shields		Inspect every 80,000 km (50,000 miles).															
Coolant level																	
Coolant* ¹¹		Replace at first 200,000 km (125,000 miles) or 10 years; after that, every 100,000 km (62,500 miles) or 5 years.															
Battery* ¹² ¹³																	
Brake lines, hoses and connections																	

Maintenance item		Number of times, maintenance was performed.															
		1	2	3	4	5	6	7	8	9	10	11	12	13	14	15	16
Brake & Clutch fluid level		I	I	I	I	I	I	I	I	I	I	I	I	I	I	I	I
Brake fluid* ¹⁴	Except below				R				R				R				R
	Petrol engine in South Africa		R		R		R		R		R		R		R		R
Disc brakes		I	I	I	I	I	I	I	I	I	I	I	I	I	I	I	I
Steering operation and linkages	Except below		I		I		I		I		I		I		I		I
	Petrol engine in South Africa	I	I	I	I	I	I	I	I	I	I	I	I	I	I	I	I
Front and rear suspension, ball joints and wheel bearing axial play			I		I		I		I		I		I		I		I
Driveshaft dust boots					I				I				I				I
Bolts and nuts on chassis and body			T		T		T		T		T		T		T		T
Body condition (for rust, corrosion and perforation)			I		I		I		I		I		I		I		I
Cabin air filter (if equipped)	Except below		R		R		R		R		R		R		R		R
	Petrol engine in South Africa	R	R	R	R	R	R	R	R	R	R	R	R	R	R	R	R
Tyre inflation pressure and tyre wear* ¹⁵		I	I	I	I	I	I	I	I	I	I	I	I	I	I	I	I
Tyre rotation	Except below	Rotate every 10,000 km (6,250 miles).															
	Petrol engine in South Africa	Rotate every 15,000 km (9,375 miles).															
Emergency flat tyre repair kit (if equipped)* ¹⁶	Except below		I		I		I		I		I		I		I		I
	Petrol engine in South Africa	I	I	I	I	I	I	I	I	I	I	I	I	I	I	I	I
Bonnet striker		I	I	I	I	I	I	I	I	I	I	I	I	I	I	I	I
Function of all lights		I	I	I	I	I	I	I	I	I	I	I	I	I	I	I	I

Chart symbols:

I: Inspect: Inspect and clean, repair, adjust, fill up, or replace if necessary.

C: Clean

T: Tighten

R: Replace

Scheduled Maintenance

Remarks:

- *1 Reset the engine oil data whenever replacing the engine oil regardless of the message/wrench indicator light display.
- *2 If the vehicle is driven in very dusty or sandy areas, clean and if necessary, replace the air filter more often than the recommended intervals.
- *3 In the countries below, inspect the spark plugs at every 10,000 km (6,250 miles) or 1 year before replacing them at the said interval.
Algeria, Angola, Bahrain, Bolivia, Burundi, B.Virgin, Cambodia, Cameroon, Chile, Costa Rica, Curacao, El Salvador, Ethiopia, Gabon, Georgia, Ghana, Guatemala, Haiti, Honduras, Hong Kong, Iran, Ivory Coast, Jordan, Kenya, Macau, Madagascar, Malaysia, Mongolia, Mozambique, Myanmar, Nigeria, Nicaragua, Oman, Panama, Papua New Guinea, Paraguay, Peru, Senegal, Seychelles, Syria, Tanzania, The Philippines, UAE, Vietnam, Zaire, Zimbabwe
- *4 If DTC P1200 is stored, clean the fuel system by using Mazda genuine deposit cleaner.
If the required tool (M-MDS) is not available, clean the fuel system by using Mazda genuine deposit cleaner without performing self-test.
Using non-genuine deposit cleaner could cause internal damage to the fuel system.
- *5 If the vehicle is driven primarily under any of the following conditions, perform "Self-test with Mazda Modular Diagnostic System (M-MDS)" at every 5,000 km.
 - a) The vehicle is idled for long periods or driven at low speeds, such as with police cars, taxis, or driver's education school car.
 - b) Driving under extremely high temperature conditions.
- *6 Applicable countries are as follows:
SKYACTIV-G and e-SKYACTIV G: Algeria, Angola, Antigua, Aruba, Bahrain, Barbados, Bermuda, Bolivia, Botswana, Brunei, Burundi, Cambodia, Cameroon, Colombia, Common Wealth of Dominica, Curacao, Ecuador, El Salvador, Ethiopia, Gabon, Ghana, Grenada, Haiti, Honduras, Indonesia, Iran, Iraq, Ivory Coast, Jordan, Kenya, Kuwait, Laos, Lesotho, Libya, Macau, Madagascar, Malaysia, Marshall islands, Mongolia, Morocco, Myanmar, Namibia, Nicaragua, Nigeria, Oman, Paraguay, Peru, Qatar, Senegal, Seychelles, South Africa, Sri Lanka, St. Lucia, St. Martin, St. Vincent, Swaziland, Syria, Tanzania, The Philippines, Trinidad and Tobago, Tunisia, USTT, Vanuatu, Vietnam, Zimbabwe
e-SKYACTIV X: Chile, Hong Kong, Iran, Macau, Mauritius, New Caledonia, Papua New Guinea, Saudi Arabia, Singapore, Thailand, Trinidad and Tobago, UAE
- *7 Top up with new AdBlue® in the urea tank.
- *8 If more than 10,000 km are driven per year, top up with new AdBlue® in the tank.
If less than 10,000 km are driven per year, drain the tank, then fill it up with new AdBlue®.
- *9 If any DTCs are stored, repair malfunction location according to applicable DTC troubleshooting. If M-MDS is not available, check if any warning lights are illuminated or flashing.
- *10 Also inspect the air conditioner drive belts, if equipped.
If the vehicle is driven primarily under any of the following conditions, inspect the drive belts more often than the recommended intervals.
 - a) Driving for long period in extremely wet or heavy rain condition.
- *11 Use of FL-22 is recommended when replacing coolant. Using coolant other than FL-22 may cause serious damage to the engine and cooling system.
- *12 Inspect the battery electrolyte level and outer appearance. The sealed battery only requires an outer appearance inspection.

- *13 Inspection is only subjected for lead-acid battery.
- *14 If the brakes are used extensively (for example, continuous hard driving or mountain driving) or if the vehicle is operated in extremely humid climates, replace the brake fluid annually.
- *15 Inspect a spare tyre if equipped.
- *16 Check the tyre repair fluid expiration date every year when performing the periodic maintenance. Replace the tyre repair fluid bottle with new one before the expiration date.

Scheduled Maintenance

Table 5

Vehicles utilizing the vehicle status monitor feature

The vehicle status monitor feature alerts you of maintenance needs by turning on the wrench indicator light or displaying a message in the instrument panel, or both.

Every maintenance must be done when the display/wrench indication comes on.

The display/wrench indication will come on before reaching the maximum interval.

Maximum interval 10,000 km (6,250 miles) or 12 months, whichever comes first.

Manually set Next Service Distance of Vehicle Status Monitor to a shorter mileage than maximum interval (50 % of maximum mileage is recommended) if the vehicle is driven primarily under any of the following conditions: Refer to the Information section in the Mazda Connect Owner's Manual about the manual setting procedure.

1. The vehicle is idled for long periods or driven at low speeds, such as with police cars, taxis, or driver's education school car.
2. Driving under dusty conditions.
3. Driving for long periods in cold temperatures or driving regularly for short distances only.
4. Driving under extremely high temperature conditions.
5. Driving continuously in mountainous regions.

Maintenance item		Number of times, maintenance was performed.															
		1	2	3	4	5	6	7	8	9	10	11	12	13	14	15	16
Engine oil & filter* ¹		R	R	R	R	R	R	R	R	R	R	R	R	R	R	R	R
Air filter* ²				R			R			R			R			R	
Fuel filter		Replace every 60,000 km (37,500 miles).															
Spark plugs* ³	e-SKYACTIV G	Replace every 64,000 km (40,000 miles).															
	SKYACTIV-G	Replace every 120,000 km (75,000 miles).															
Drive belts* ⁴		I	I	I	I	I	I	I	I	I	I	I	I	I	I	I	I
Coolant level		I	I	I	I	I	I	I	I	I	I	I	I	I	I	I	I
Fuel lines and hoses		I	I	I	I	I	I	I	I	I	I	I	I	I	I	I	I
Vacuum brake booster and hose	With vacuum booster	I	I	I	I	I	I	I	I	I	I	I	I	I	I	I	I
Hoses and tubes for emission			I		I		I		I		I		I		I		I
Exhaust system and heat shields		Inspect every 80,000 km (50,000 miles).															
Coolant* ⁵		Replace at first 200,000 km (125,000 miles) or 10 years; after that, every 100,000 km (62,500 miles) or 5 years.															
Battery* ^{6,7}		I	I	I	I	I	I	I	I	I	I	I	I	I	I	I	I
Brake lines, hoses and connections		I	I	I	I	I	I	I	I	I	I	I	I	I	I	I	I

Maintenance item	Number of times, maintenance was performed.															
	1	2	3	4	5	6	7	8	9	10	11	12	13	14	15	16
Brake & Clutch fluid level	I	I	I	I	I	I	I	I	I	I	I	I	I	I	I	I
Brake fluid* ⁸		R		R		R		R		R		R		R		R
Disc brakes	I	I	I	I	I	I	I	I	I	I	I	I	I	I	I	I
Steering operation and linkages	I	I	I	I	I	I	I	I	I	I	I	I	I	I	I	I
Front and rear suspension, ball joints and wheel bearing axial play	I	I	I	I	I	I	I	I	I	I	I	I	I	I	I	I
Driveshaft dust boots		I		I		I		I		I		I		I		I
Bolts and nuts on chassis and body	T	T	T	T	T	T	T	T	T	T	T	T	T	T	T	T
Body condition (for rust, corrosion and perforation)	I	I	I	I	I	I	I	I	I	I	I	I	I	I	I	I
Cabin air filter (if equipped)	R	R	R	R	R	R	R	R	R	R	R	R	R	R	R	R
Tyre inflation pressure and tyre wear* ⁹	I	I	I	I	I	I	I	I	I	I	I	I	I	I	I	I
Tyre rotation	Rotate every 10,000 km (6,250 miles).															
Emergency flat tyre repair kit (if equipped)* ¹⁰	I	I	I	I	I	I	I	I	I	I	I	I	I	I	I	I
Bonnet striker	I	I	I	I	I	I	I	I	I	I	I	I	I	I	I	I
Function of all lights	I	I	I	I	I	I	I	I	I	I	I	I	I	I	I	I

Chart symbols:

- I:** Inspect: Inspect and clean, repair, adjust, fill up, or replace if necessary.
- C:** Clean
- T:** Tighten
- R:** Replace

Remarks:

- *1 Reset the engine oil data whenever replacing the engine oil regardless of the message/wrench indicator light display.
- *2 If the vehicle is driven in very dusty or sandy areas, clean and if necessary, replace the air filter more often than the recommended intervals.
- *3 For Chile, inspect the spark plugs at every 10,000 km (6,250 miles) or 1 year before replacing them at the said interval.
- *4 Also inspect the air conditioner drive belts, if equipped.
If the vehicle is driven primarily under any of the following conditions, inspect the drive belts more often than the recommended intervals.
 - a) Driving for long period in extremely wet or heavy rain condition.
- *5 Use of FL-22 is recommended when replacing coolant. Using coolant other than FL-22 may cause serious damage to the engine and cooling system.

Scheduled Maintenance

- *6 Inspect the battery electrolyte level and outer appearance. The sealed battery only requires an outer appearance inspection.
- *7 Inspection is only subjected for lead-acid battery.
- *8 If the brakes are used extensively (for example, continuous hard driving or mountain driving) or if the vehicle is operated in extremely humid climates, replace the brake fluid annually.
- *9 Inspect a spare tyre if equipped.
- *10 Check the tyre repair fluid expiration date every year when performing the periodic maintenance. Replace the tyre repair fluid bottle with new one before the expiration date.

Daily Inspection

We highly recommend that these items be inspected before driving.

- Engine Oil Level (page 9-33)
- Coolant Level (page 9-37)
- Brake Fluid Level (page 9-39)
- Washer Fluid Level (page 9-40)
- Lead-acid Battery Maintenance (page 9-41)
- Tyre Inflation Pressure (page 9-52)

Improper or incomplete service may result in problems. This section gives instructions only for items that are easy to perform.

Several procedures can be done only by a qualified service technician with special tools.

Improper do-it yourself maintenance during the warranty period may affect warranty coverage. For details, read the separate Mazda Warranty statement provided with the vehicle. If you are unsure about any servicing or maintenance procedure, have it done by an expert repairer (we recommend an Authorised Mazda Repairer).

There are strict environmental laws regarding the disposal of waste fluids. Please dispose of your waste properly and with due regard to the environment.

Entrust the oil and fluid changes of your vehicle to an expert repairer (we recommend an Authorised Mazda Repairer).

Warnings and Cautions for Daily Inspection

WARNING

Do not perform maintenance work if you lack sufficient knowledge and experience or the proper tools and equipment to do the work. Have maintenance work done by a qualified technician.

Performing maintenance work on a vehicle is dangerous if not done properly. You can be seriously injured while performing some maintenance procedures.

If you must run the engine while working under the bonnet, make certain that you remove all jewellery (especially rings, bracelets, watches, and necklaces) and all neckties, scarves, and similar loose clothing before getting near the cooling fan which may turn on unexpectedly. Working under the bonnet with the engine operating is dangerous. It becomes even more dangerous when you wear jewellery, loose clothing or have long hair or a long beard. Either can become entangled in moving parts and result in injury.

Daily Inspection



Pull over to a safe location, then switch the vehicle power off and make sure the fan is not running before attempting to work near the cooling fan.

Working near the cooling fan when it is running is dangerous. The fan could continue running indefinitely even if the engine has stopped and the engine compartment temperature is high. You could be hit by the fan and seriously injured.

Do not leave items in the motor compartment.

After you have finished checking or doing servicing in the engine compartment, do not forget and leave items such as tools or rags in the motor compartment. Tools or other items left in the engine compartment could cause the engine damage or a fire leading to an unexpected accident.



When using a chassis roller, turn the following systems off to prevent them from mis-operating while the vehicle is running on the chassis roller.

- Mazda Radar Cruise Control (MRCC)
- Mazda Radar Cruise Control with Stop & Go function (MRCC with Stop & Go function)
- Cruising & Traffic Support (CTS)
- Smart Brake Support (SBS)

Checking the Inspection Locations and Inspection Items

SKYACTIV-G

Left-hand drive model

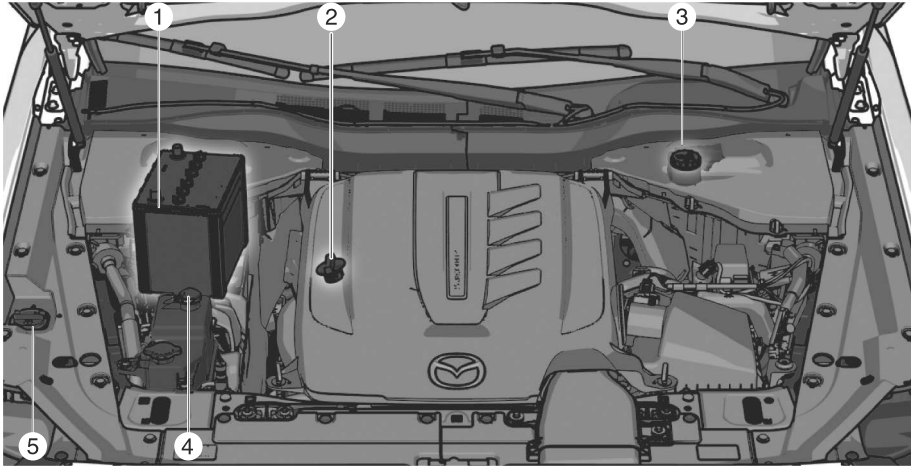

Right-hand drive model

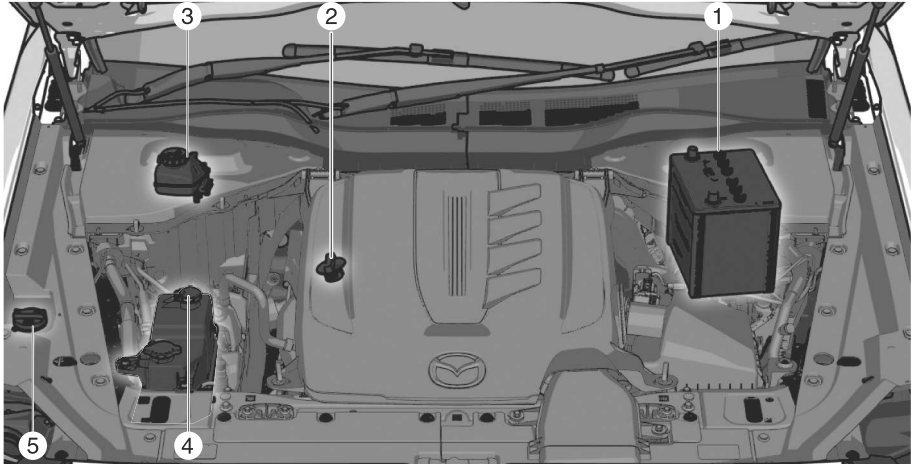

1. Lead-acid battery
2. Engine oil
3. Brake fluid
4. Coolant
5. Windscreen washer fluid

Engine Compartment Inspection

e-SKYACTIV G

Left-hand drive model

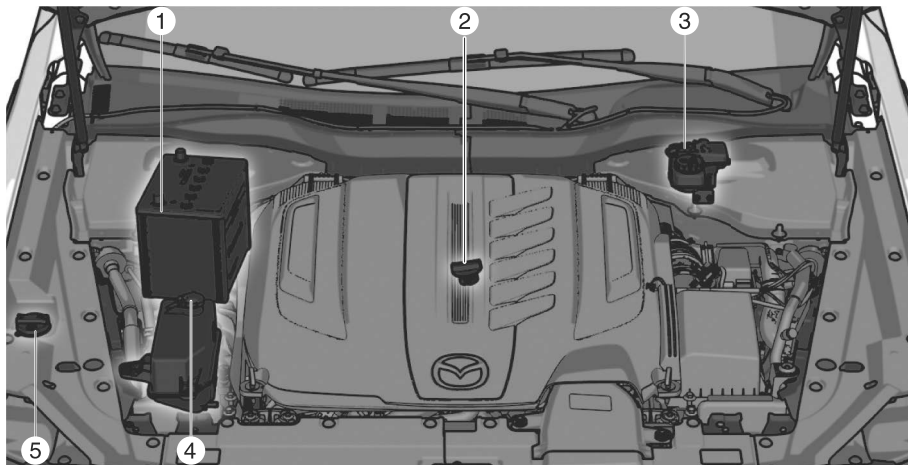

Right-hand drive model

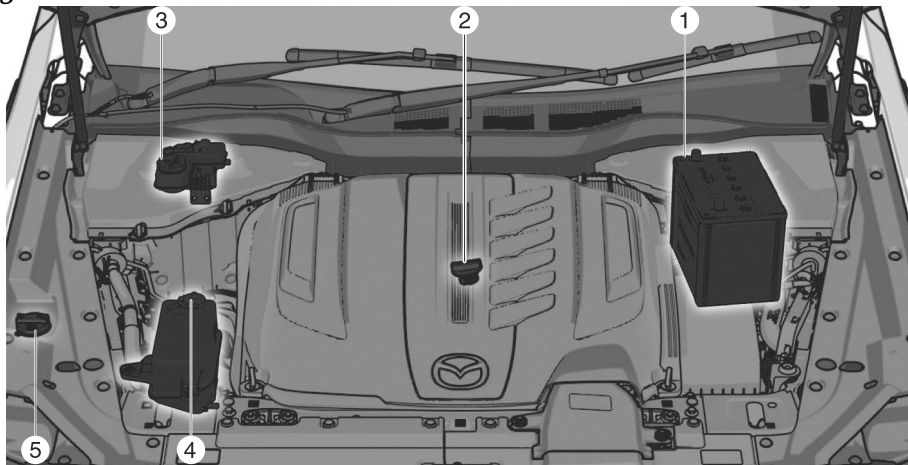

1. Lead-acid battery
2. Engine oil
3. Brake fluid
4. Coolant
5. Windscreen washer fluid

e-SKYACTIV D

Left-hand drive model

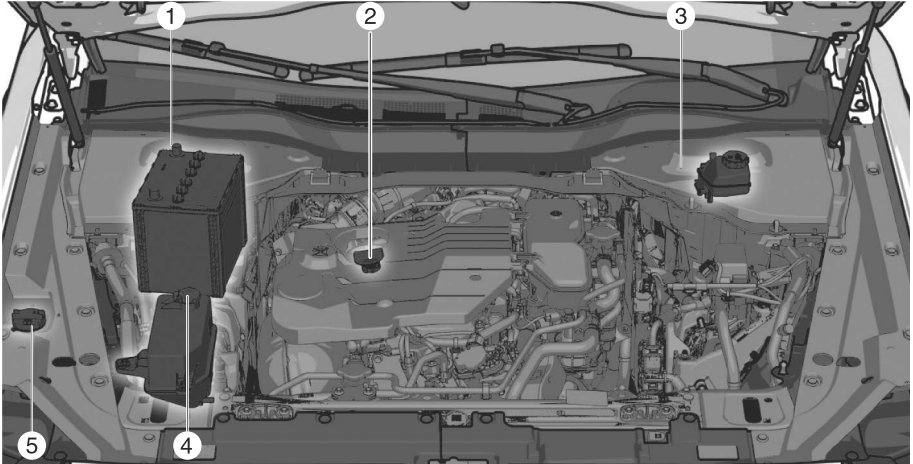

Right-hand drive model

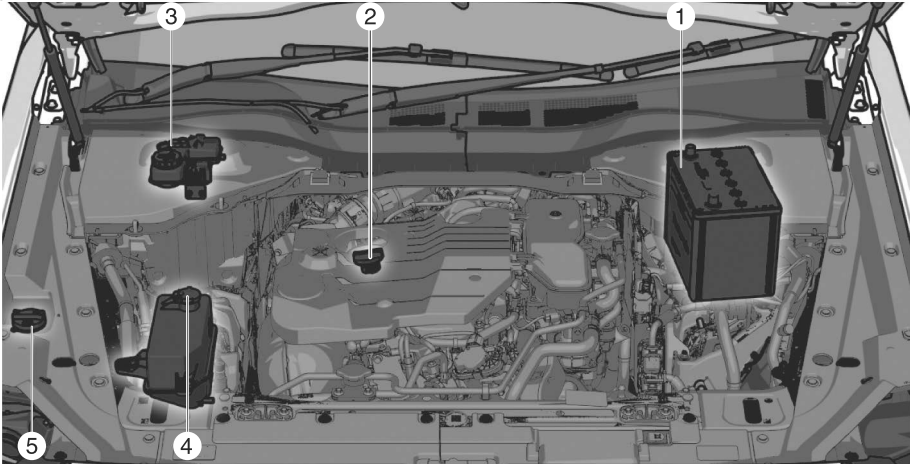

1. Lead-acid battery
2. Engine oil
3. Brake fluid
4. Coolant
5. Windscreen washer fluid

Engine Compartment Inspection

Opening the engine cover

1. Open the bonnet (page 4-27).
- 2.

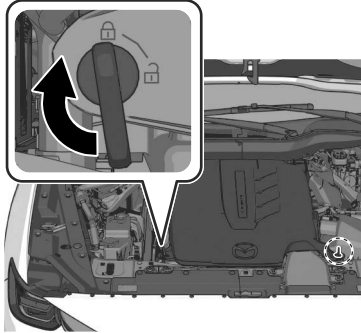

- 3.

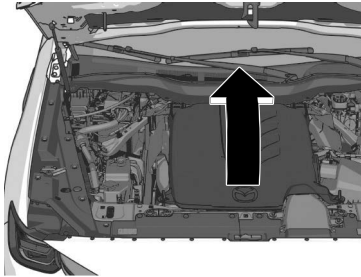

- 4.

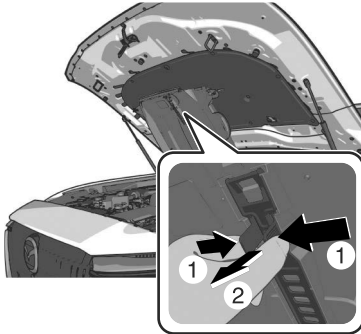

Engine Compartment Inspection

5.

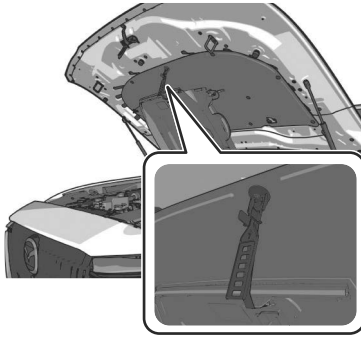
**⚠ CAUTION**

Remove the strap when opening/closing the bonnet. If the bonnet is opened/closed while the strap is engaged, the strap or hook may be damaged.

Closing the engine cover

1.



2. Pinch the strap and press it in until a click sound is heard, and store.

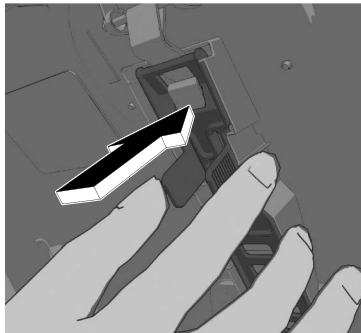

Engine Compartment Inspection

3.

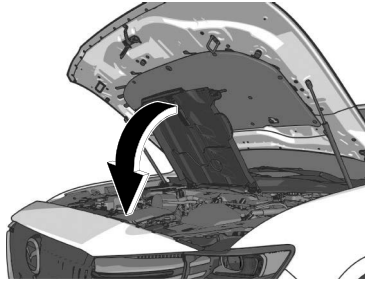

4.

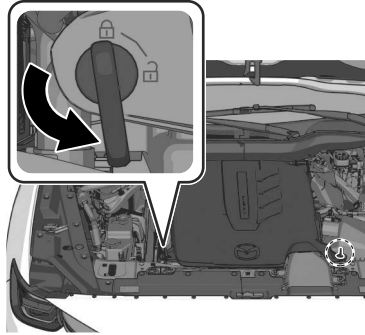

5. Make sure that the engine cover is securely closed.

Inspecting Engine Oil



Do not overfill the engine oil. This may cause engine damage.

Use centre display screen indication to inspect the engine oil level.

1. Make sure the bonnet is closed.
2. Start the engine.
3. Select "Information" on the Home screen to display the vehicle status monitor.
4. Select "Vehicle Status Monitor".
5. Select "Engine Oil Level".
6. Select "Start".

Measurement of the engine oil level begins. Do not depress the accelerator pedal during the measurement.

NOTE

(SKYACTIV-G)

If measurement conditions not shown on the display are not met such as when warm-up operation has not been completed due to low outdoor temperatures, the measurement error screen may be displayed. In this case, drive the vehicle for a certain period of time to complete the warm-up operation, stop the engine and leave it for about 10 minutes, and then perform the measurement procedure again.

(e-SKYACTIV G and e-SKYACTIV D)

If measurement conditions not shown on the display are not met such as when warm-up operation has not been completed due to low outdoor temperatures, "Engine On: No" may be displayed even if the engine is running or the measurement error screen may be displayed after measurement starts. In this case, drive the vehicle for a certain period of time to complete the warm-up operation, stop the engine and leave it for about 10 minutes, and then perform the measurement procedure again.

7. Switch the vehicle power OFF.

NOTE

After the measurement is completed, the engine does not stop automatically.

Recommended Oil

In order to keep the maintenance interval (page 9-5) and to protect the engine from damage caused by poor lubrication, it is vitally important to make use of engine oil with the correct specification. Do not use oils which do not meet the following specifications or requirements. Use of unsuitable oil may lead to engine damage which is not covered by the Mazda Warranty.

Engine Compartment Inspection

Engine oil viscosity, or thickness, has an effect on fuel economy and cold-weather operation (starting and oil flow).

Low-viscosity engine oils can provide improved fuel economy and cold-weather performance.

When choosing an oil, consider the temperature range your vehicle will operate in before the next oil change.

Then select the recommended viscosity from the chart.

SKYACTIV-G

(Taiwan)

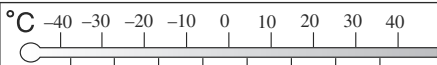
Temperature Range SAE Viscosity Numbers	
Grade	°C -40 -30 -20 -10 0 10 20 30 40 
	°F -40 -20 0 20 40 60 80 100
Recommended Oils	
Mazda Original Oil Supra-X 0W-20	◀ 0W-20 ▶
Mazda Original Oil Ultra 5W-30	◀ 5W-30 ▶
Alternative Oil Quality	
API SN or higher, or ACEA A5/B5	◀ 0W-20 ▶
	◀ 5W-30 ▶

(Except Taiwan)

Temperature Range SAE Viscosity Numbers	
Grade	°C -40 -30 -20 -10 0 10 20 30 40 
	°F -40 -20 0 20 40 60 80 100
API SL or higher*1	◀ 0W-20 0W-30 ▶
	◀ 5W-20 5W-30 ▶
	◀ 10W-30 ▶

*1 Use API SM or higher in Kazakhstan.

Engine Compartment Inspection

e-SKYACTIV G (Taiwan)

Temperature Range SAE Viscosity Numbers	
Grade	
Recommended Oils	
Mazda Original Oil Supra-X 0W-20	
Mazda Original Oil Ultra 5W-30	
Alternative Oil Quality	
API SN or higher, or ACEA A5/B5	0W-20
	5W-30

(Except Taiwan)

Temperature Range SAE Viscosity Numbers	
Grade	
API SN or higher	

Engine Compartment Inspection

e-SKYACTIV D (Europe and Taiwan)

Temperature Range SAE Viscosity Numbers	
Grade	
Recommended oils	
Mazda Original Oil Supra DPF 0W-20/0W-30	
Mazda Original Oil Ultra DPF 5W-30	
Alternative Oil Quality	
ACEA C3	0W-30
	5W-30

(Except Europe and Taiwan)

Temperature Range SAE Viscosity Numbers	
Grade	
ACEA C3	0W-30
	5W-30

CAUTION

- Using oils of viscosity besides those recommended for specific temperature ranges could result in engine damage.
- (e-SKYACTIV D)
e-SKYACTIV D uses specified oil. Please confirm the specification in owner's manual. If engine oil other than the specified oil is used, the Diesel Particulate Filter effective period of use will be shortened or the Diesel Particulate Filter may be damaged.

NOTE

(SKYACTIV-G and e-SKYACTIV G)

It is normal for all engines to consume engine oil under normal driving conditions. Engine oil consumption may be as high as 0.8 L/1,000 km (1 L/800 miles). This may be as a result of evaporation, internal ventilation or burning of the lubricating oil in the working engine. Oil consumption may be higher when the engine is new due to the running-in process. Oil consumption is also dependant on engine speed and engine load. Under extreme driving conditions, oil consumption may be higher.

Inspecting the Coolant

WARNING

Do not use a match or live flame in the engine compartment. DO NOT ADD COOLANT WHEN THE ENGINE IS HOT.

A hot engine is dangerous. If the engine has been running, parts of the engine compartment can become very hot. You could be burned. Carefully inspect the engine coolant in the coolant reservoir, but do not open it.



Pull over to a safe location, then switch the vehicle power off and make sure the fan is not running before attempting to work near the cooling fan.

Working near the cooling fan when it is running is dangerous. The fan could continue running indefinitely even if the engine has stopped and the engine compartment temperature is high. You could be hit by the fan and seriously injured.

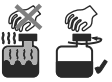

Do not remove either cooling system cap when the engine and radiator are hot.

When the engine and radiator are hot, scalding coolant and steam may shoot out under pressure and cause serious injury.

NOTE

Changing the coolant should be done by an expert repairer (we recommend an Authorised Mazda Repairer).

Inspect the antifreeze protection and coolant level in the coolant reservoir at least once a year—at the beginning of the winter season—and before travelling where temperatures may drop below freezing.

Inspect the condition and connections of all cooling system and heater hoses. Replace any that are swollen or deteriorated.

(SKYACTIV-G)

There are two cooling circuits: one for the automatic transmission, and the other for the engine. Check both circuits.

The coolant should be at full in the radiator and between the F and L marks, and between the FULL and LOW marks on the coolant reservoir when the engine is cool.

There are two coolant reservoir tanks. Check each of them.

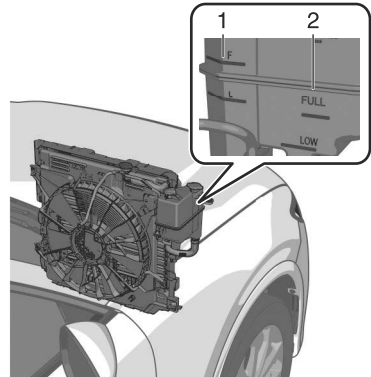

1. The tank for the automatic transmission
2. The tank for the engine

Engine Compartment Inspection

(e-SKYACTIV G and e-SKYACTIV D)

The coolant should be at full in the radiator and between the FULL and LOW marks on the coolant reservoir when the engine is cool.

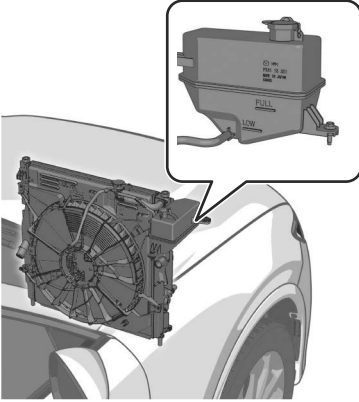

If it is at or near the LOW position, add enough coolant to the coolant reservoir to provide freezing and corrosion protection and to bring the level to FULL.

Securely tighten the coolant reservoir tank cap after adding coolant.

CAUTION

- Radiator coolant will damage paint. Rinse it off quickly if spilled.
- If the "FL22" mark is shown on or near the cooling system cap, use of FL-22 is recommended when replacing engine coolant. Using engine coolant other than FL-22 may cause serious damage to the engine and cooling system.



If the coolant reservoir is empty or new coolant is required frequently, consult an expert repairer (we recommend an Authorised Mazda Repairer).

Inspecting the Brake Fluid

! WARNING

If the brake fluid level is low, have the brakes inspected.

A low brake fluid level is dangerous. A low level could indicate brake lining wear or a brake system leak which could cause the brakes to fail and lead to an accident.

Inspect the fluid level in the reservoir regularly. It should be kept between the MAX and MIN lines.

The level normally drops with accumulated distance, a condition associated with wear of brake linings. If it is excessively low, have the brake system inspected by an expert repairer (we recommend an Authorised Mazda Repairer).

Before inspecting the brake fluid, remove the hole cover.

The position of the brake fluid reservoir differs depending on whether the vehicle is a left-hand or right-hand drive.

Refer to Checking the Inspection Locations and Inspection Items on page 9-27.

Removing the Hole Cover.

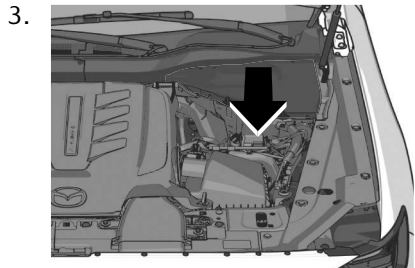
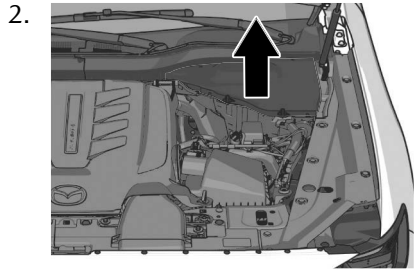
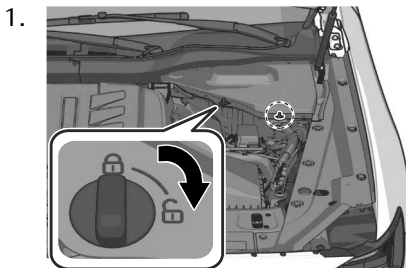

Installing the Hole Cover.

1. Insert the hole cover into the cowl grille.
Make sure that the hole cover holds the cowl grille and the knobs are in the correct position.

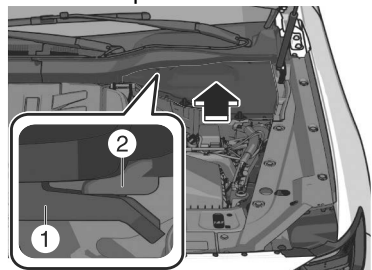

1. The hole cover
2. The cowl grille

Engine Compartment Inspection

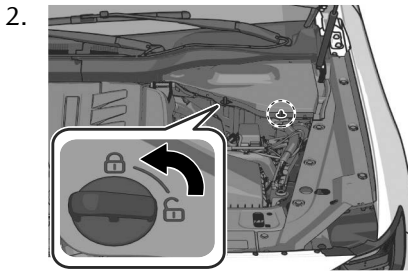

Brake fluid reservoir

SKYACTIV-G

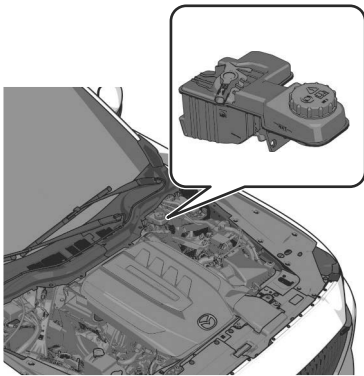

e-SKYACTIV D

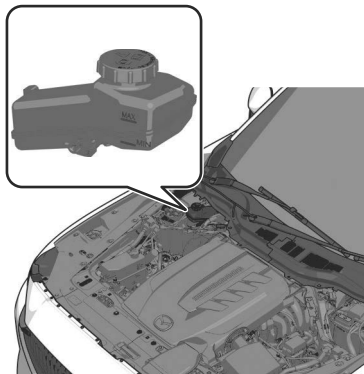

Replenishing Windscreen Washer Fluid

! WARNING

Use only windscreen washer fluid or plain water in the reservoir.

Using radiator antifreeze as washer fluid is dangerous. If sprayed on the windscreen, it will dirty the windscreen, affect your visibility, and could result in an accident.

! CAUTION

Do not use soapy water or engine antifreeze in the reservoir as it could cause paint discolouration or pump damage.

NOTE

Replenish the washer fluid on a flat surface. If the vehicle is tilted, washer fluid may not fill sufficiently.

Add washer fluid under any of the following conditions.

- The top of the fluid level is low.
- The Low Washer Fluid Level Warning Indication/Warning Light (if equipped) turns on.

Engine Compartment Inspection

- The top of the fluid level is lower than L (if equipped).

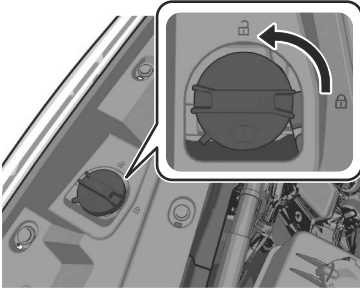

Use plain water if washer fluid is unavailable. But use only washer fluid in cold weather to prevent it from freezing.

Inspecting Lead-acid Battery

WARNING



Read the following precautions carefully before using the lead-acid battery or inspecting to ensure safe and correct handling.



Always wear eye protection when working near the lead-acid battery.

Working without eye protection is dangerous. Lead-acid battery fluid contains SULPHURIC ACID which could cause blindness if splashed into your eyes. Also, hydrogen gas produced during normal lead-acid battery operation, could ignite and cause the lead-acid battery to explode.



Wear eye protection and protective gloves to prevent contact with lead-acid battery fluid.

Spilled lead-acid battery fluid is dangerous.

Lead-acid battery fluid contains SULPHURIC ACID which could cause serious injuries if it gets in eyes, or on the skin or clothing. If this happens, immediately flush your eyes with water for 15 minutes or wash your skin thoroughly and get medical attention.

Engine Compartment Inspection



Always keep lead-acid batteries out of the reach of children.

Allowing children to play near lead-acid batteries is dangerous. Lead-acid battery fluid could cause serious injuries if it gets in the eyes or on the skin.



Keep flames and sparks away from lead-acid battery cells and do not allow metal tools to contact the positive (+) or negative (-) terminal of the lead-acid battery when working near a lead-acid battery. Do not allow the positive (+) terminal to contact the vehicle body.

Flames and sparks near lead-acid battery cells are dangerous. Hydrogen gas, produced during normal lead-acid battery operation, could ignite and cause the lead-acid battery to explode. An exploding lead-acid battery can cause serious burns and injuries. Keep all flames including cigarettes and sparks away from lead-acid battery cells.



Keep all flames and sparks away from lead-acid battery cells because hydrogen gas is produced from lead-acid battery cells while charging the lead-acid battery or adding lead-acid battery fluid.

Flames and sparks near lead-acid battery cells are dangerous. Hydrogen gas, produced during normal lead-acid battery operation, could ignite and cause the lead-acid battery to explode. An exploding lead-acid battery can cause serious burns and injuries. Keep all flames including cigarettes and sparks away from lead-acid battery cells.

Before performing lead-acid battery maintenance, remove the hole cover and the lead-acid battery cover.

Removing the Hole Cover

1.

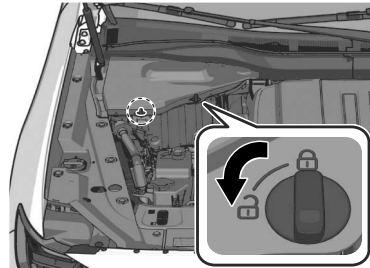

2.

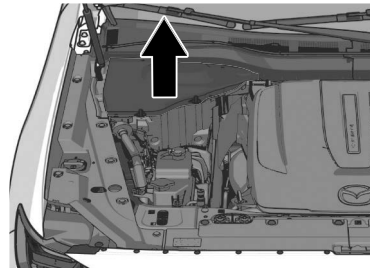

Engine Compartment Inspection

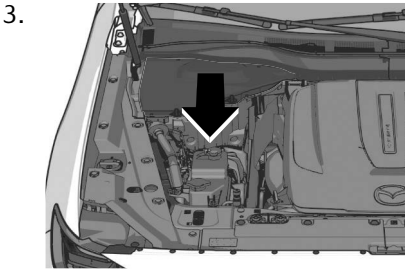

Installing the Hole Cover

1. Insert the hole cover into the cowl grille.
Make sure that the hole cover holds the cowl grille and the knobs are in the correct position.

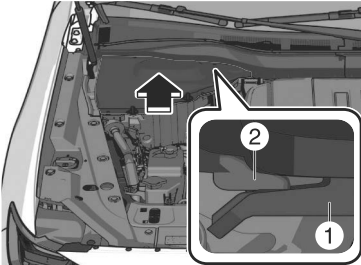

1. The hole cover
2. The cowl grille

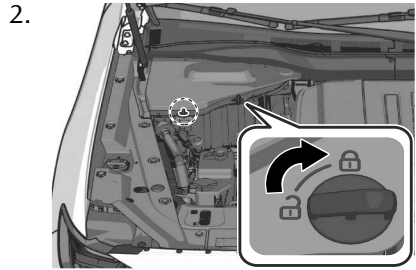

Removing the Lead-acid Battery Cover

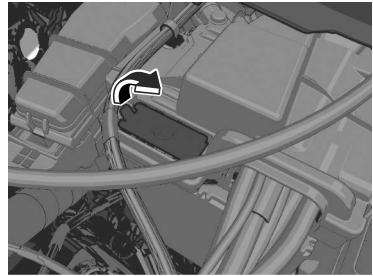

Maintaining Lead-acid Battery

To get the best service from a lead-acid battery:

- Keep it securely mounted.
- Keep the top clean and dry.
- Keep terminals and connections clean, tight, and coated with petroleum jelly or terminal grease.
- Rinse off spilled electrolyte immediately with a solution of water and baking soda.

Engine Compartment Inspection

- If the vehicle will not be used for an extended time, disconnect the lead-acid battery leads and charge the lead-acid battery every 6 weeks.

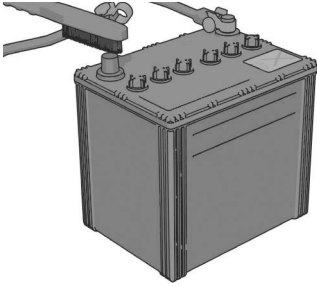

Replacing lead-acid battery

Contact an expert repairer (we recommend an Authorised Mazda Repairer) for lead-acid battery replacement.

Replacing the Fuses

Contact an expert repairer (we recommend an Authorised Mazda Repairer) for fuse replacement.

Replenishing AdBlue® (With Selective Catalytic Reduction (SCR) System)*

CAUTION

- If AdBlue® gets in your mouth, wash your mouth with a large amount of water immediately and seek medical attention. If AdBlue® is mistakenly swallowed, drink 1 to 2 cups of water immediately and seek medical attention.
- If AdBlue® gets in your eyes, rinse them with running water immediately and seek medical attention.
- Do not use AdBlue® when 2 years have elapsed from the production date indicated on the container or the use period has expired. If AdBlue® with an expired use period is used, the Selective Catalytic Reduction (SCR) System may not operate normally.
- Do not store AdBlue® in the vehicle. AdBlue® may deteriorate or the interior may be damaged due to fluid leakage from the container.
- If AdBlue® gets on the painted surface or the interior, wash it off with water or wipe it off with a wet cloth immediately. Otherwise, it may damage the painted surface or the interior.
- If AdBlue® crystals form on the painted surface or the interior, wipe them off with a wet cloth. Otherwise, it may damage the painted surface or the interior.
- Store AdBlue® in a place out of the reach of children.
- Do not put AdBlue® into a different container. There may be foreign matter in the container. If AdBlue® containing foreign matter is used, it could cause a problem with the SCR system. In addition, changing containers is dangerous because it increases the risk of accidental ingestion.
- Use a Mazda genuine product or a product conforming to ISO22241-1 for AdBlue®. If incompatible AdBlue® is used, the Selective Catalytic Reduction (SCR) system may not operate normally. For the recommended AdBlue®, consult the nearest expert repairer (we recommend an Authorised Mazda Repairer).
- Do not dilute AdBlue® with water. If diluted AdBlue® is used, it could cause a problem with the SCR system or damage it.
- Do not add any fluid other than AdBlue® to the urea tank. If any fluid other than AdBlue® is added, it could cause a problem with the SCR system or damage it. Do not switch the ignition ON, and contact an expert repairer (we recommend an Authorised Mazda Repairer).
- When adding AdBlue®, use a bottle with an anti-spill nozzle. If a bottle without an anti-spill nozzle or a commercial dispenser at a petrol station is used, it could cause leakage or the AdBlue® fluid to spray out.
- Do not overfill the AdBlue® fluid. If AdBlue® is added unnecessarily, it could cause a problem with the urea tank or damage it. Always use a bottle with an auto-stop function and stop adding fluid when the auto-stop function operates.

Engine Compartment Inspection

NOTE

- When adding AdBlue® during low temperatures (−11 °C (12 °F) or less), move the vehicle to a warm location. If the AdBlue® starts to freeze, it may not flow correctly and the correct amount may not have been added. In addition, if the fluid freezes in the urea tank, you may not be able to tell if the correct amount of fluid was added.
- Replenishment of AdBlue® by an expert repairer (we recommend an Authorised Mazda Repairer) is recommended. If you want to replenish the AdBlue® yourself, follow the replenishment procedure below.

1. Stop the vehicle on level ground.
2. Switch the vehicle power OFF.
3. Open the fuel-filler flap.
Refer to Refuelling on page 5-120.
4. Open the cap of the AdBlue® filler port.

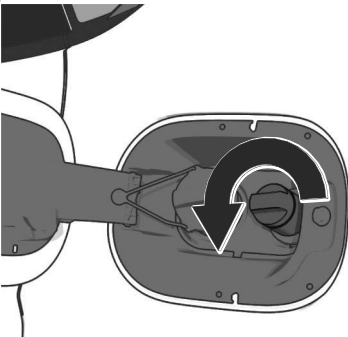

5. Remove the cap of a bottle containing AdBlue®, insert the bottle into the AdBlue® filler port, and screw it in lightly until it stops. The urea tank capacity is 6.7 L (7.0 US qt, 5.8 Imp qt).

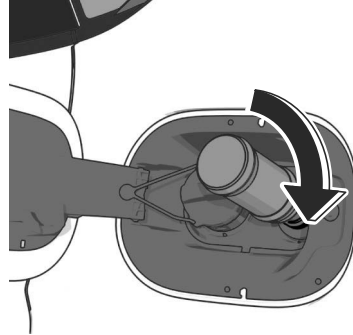

CAUTION

If too much AdBlue® is added, the SCR system might display a warning. Contact an expert repairer (we recommend an Authorised Mazda Repairer) if a warning is displayed. If the warning remains displayed, the urea tank may have a problem or it may be damaged.

NOTE

- If excessive force is applied when pressing in the bottom of the bottle, the bottle or the AdBlue® filler port may be damaged.
- When the urea tank is full, stop adding AdBlue® because the flow from the bottle slows down by the bottle's auto-stop function. If you continue adding AdBlue®, the urea tank will overflow.

6. Press in the bottom of the bottle straight and add AdBlue®.

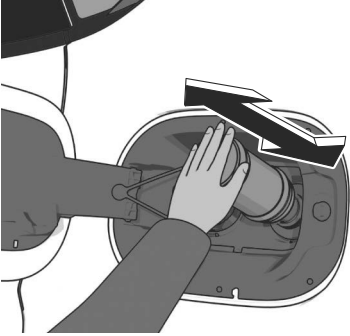

7. Remove the bottle in the reverse order of the insertion. At this time, be careful of AdBlue® dripping from the bottle.
8. Tighten the cap of the AdBlue® filler port until you hear two or more click sounds.
9. Switch the vehicle power ON once.
10. Check no Selective Catalytic Reduction (SCR) Warning Light is displayed on the Multi-information Display while the vehicle is stopped.
11. Switch the ignition OFF.
If the indication remain unchanged even after one minute has passed with the vehicle stopped, contact an expert repairer (we recommend an Authorised Mazda Repairer).

Inspecting Body Lubrication

All moving points of the body, such as door and bonnet hinges and locks, should be lubricated each time the engine oil is changed. Use a non-freezing lubricant on locks during cold weather.

Make sure the bonnet's secondary latch keeps the bonnet from opening when the primary latch is released.

Vehicle Exterior Inspection

Checking the Inspection Locations and Inspection Items

Front

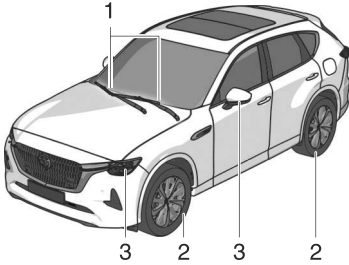

Rear

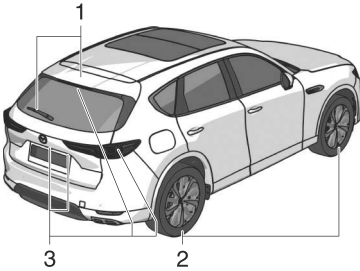

1. Windscreen wipers
2. Tyres
3. Light bulbs

Replacing Windscreen Wiper Blade Rubbers

CAUTION

- Hot waxes applied by automatic car washers have been known to affect the wiper's ability to clean windows.
- An operation malfunction may occur or the wiper effectiveness may be reduced if a water-repellent coating is used.
- To prevent damage to the wiper blades, do not use petrol, paraffin, paint thinner, or other solvents on or near them.
- When the wiper lever is in the AUTO position and the vehicle power is switched ON, the wipers may move automatically in the following cases:
 - If the windscreen above the rain sensor is touched.
 - If the windscreen above the rain sensor is wiped with a cloth.
 - If the windscreen is struck with a hand or other object.
 - If the rain sensor is struck with a hand or other object from inside the vehicle.

Be careful not to pinch hands or fingers as it may cause injury, or damage the wipers. When washing or servicing the vehicle, make sure the wiper lever is in the OFF position.

- Before lifting the windscreen wiper blades off the windscreen, always follow the procedure for moving the windscreen wiper blades. Otherwise, a wiper blade, wiper arm, or the bonnet could be damaged.

Contamination of either the windscreen or the blades with foreign matter can reduce wiper effectiveness. Common sources are insects, tree sap, and hot wax treatments used by some commercial car washes.

If the blades are not wiping properly, clean the window and blades with a good cleaner or mild detergent; then rinse thoroughly with clean water. Repeat if necessary.

NOTE

You can replace the wiper blades yourself, however you cannot replace the wiper arms.

If you want to replace the wiper arms, consult an expert repairer (we recommend an Authorised Mazda Repairer).

Replacing Front Windscreen Wiper Blade rubbers

1. Move the wipers to the service positions using the following procedure.
 - a) Switch the vehicle power ON.
 - b) Switch the vehicle power OFF.
 - c) Press up the wiper switch to the MIST position 2 times within 30 seconds after switching the vehicle power OFF. When the procedure is completed, the wipers operate and they stop at the service positions.
2. Raise the wiper arms.

3. Slide the blade component in the direction of the arrow while pressing the wiper arm tab to remove the blade component from the wiper arm.

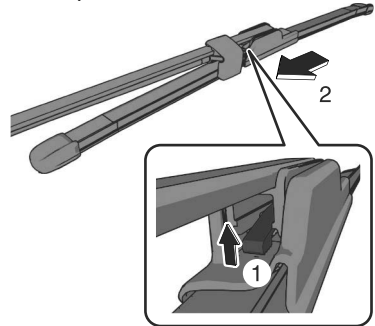

- 4.

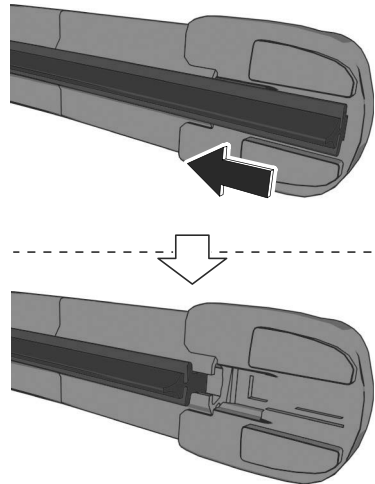

Vehicle Exterior Inspection

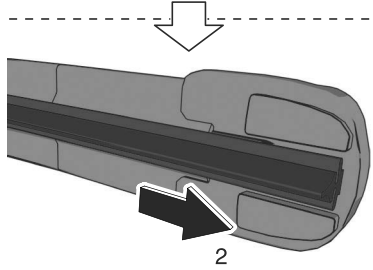
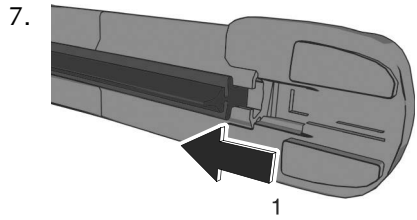
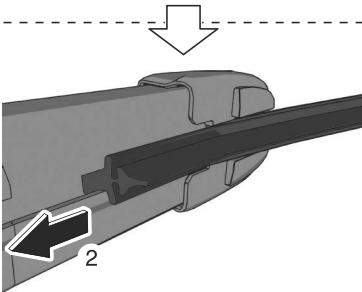
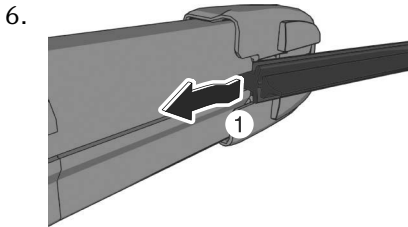
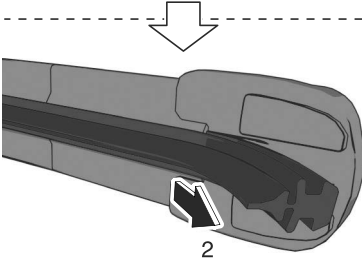
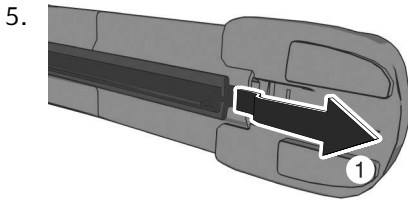

8. Make sure that the blade rubber is correctly installed to the blade holder.

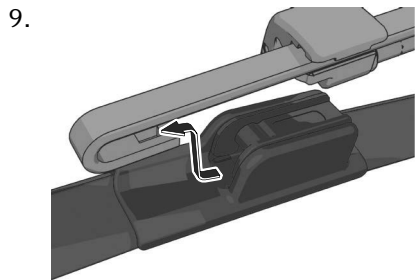

10. Slowly lower the wiper arms onto the windscreen.

 **CAUTION**

To prevent damage to the windscreen let the wiper arm down easily, do not let it slap down on the windscreen.

11. Move the wipers to their initial positions using the following procedure.
 - a) Make sure that the wipers are set on the windscreen.
 - b) Switch the vehicle power ON.
 - c) Press up the wiper switch to the MIST position 2 times.

Replacing Rear Windscreen Wiper Blade rubber

! CAUTION

To prevent damage to the wiper arm and other components, do not move the wiper by hand.

1. Raise the wiper arm and rotate the wiper blade to the right until it unlocks, then remove the blade.

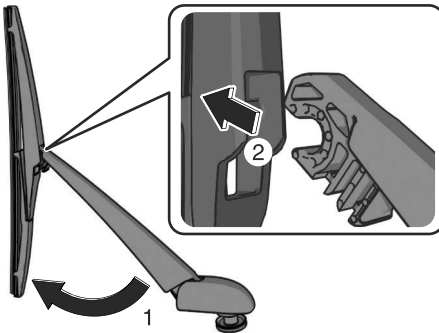

! CAUTION

To prevent damage to the rear window, do not let the wiper arm fall on it.

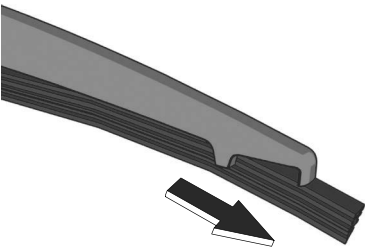
2. 
3. Remove the metal stiffeners from the blade rubber and install them in the new blade rubber.

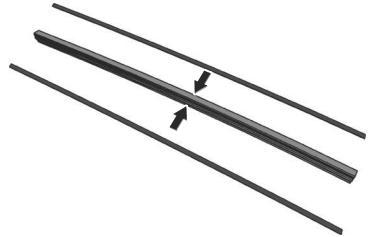

! CAUTION

Do not bend or discard the stiffeners. You need to use them again.

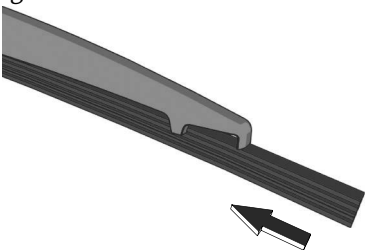
4. 
5. Install the blade assembly in the reverse order of removal.

Inspecting the Tyres

About Tyres

For reasons of proper performance, safety, and better fuel economy, always maintain recommended tyre inflation pressures and stay within the recommended load limits and weight distribution.

WARNING

Using Different Tyre Types.

Driving your vehicle with different types of tyres is dangerous. It could cause poor handling and poor braking; leading to loss of control.

Except for the limited use of the temporary spare tyre, use only the same type tyres (radial, bias-belted, bias-type) on all four wheels.

Using Wrong-Sized Tyres.

Using any other tyre size than what is specified for the vehicle (page 10-91) is dangerous. It could seriously affect ride, handling, ground clearance, tyre clearance, and speedometer calibration. This could cause you to have an accident. Use only tyres that are the correct size specified for the vehicle.

Inspecting tyre inflation pressure

WARNING

Always inflate the tyres to the correct pressure.

Overinflation or underinflation of tyres is dangerous. Adverse handling or unexpected tyre failure could result in a serious accident.

Refer to Tyres on page 10-91.

Use only a Mazda-genuine tyre valve cap.

Use of a non-genuine part is dangerous as the correct tyre air pressure cannot be maintained if the tyre valve becomes damaged. If the vehicle is driven under this condition, the tyre air pressure will decrease which could result in a serious accident. Do not use any part for the tyre valve cap that is not a Mazda-genuine part.

Inspect all tyre pressures monthly (including the spare*) when the tyres are cold. Maintain recommended pressures for the best ride, handling, and minimum tyre wear.

Refer to the specification charts (page 10-91).

NOTE

- Underinflation or overinflation can cause a harsh ride, reduced fuel economy, a greater possibility of damage from road hazards, uneven and accelerated tyre wear, and poor sealing of the tyre bead, which will deform the wheel and cause separation of tyre from rim.
- Keep your tyre pressure at the correct levels. If one frequently needs inflating, have it inspected.

Rotating the Tyres

WARNING

Rotate tyres periodically.

Irregular tyre wear is dangerous. To equalize tread wear for maintaining good performance in handling and braking, rotate the tyres periodically or sooner if irregular wear develops. Please refer to Scheduled maintenance for your tyre rotation interval.

During rotation, inspect them for correct balance.

NOTE

(Without temporary spare tyre)

Because your vehicle is not equipped with a spare tyre, you cannot do a tyre rotation safely with the jack that comes with your vehicle. Have an expert repairer (we recommend an Authorised Mazda Repairer) perform tyre rotation.

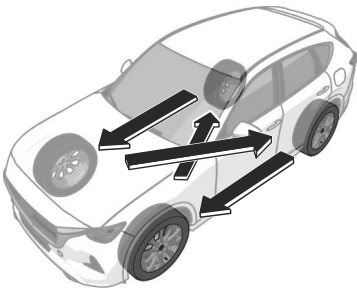

Do not include (TEMPORARY USE ONLY) spare tyre in rotation. Also, inspect them for uneven wear and damage. Abnormal wear is usually caused by one or a combination of the following:

- Incorrect tyre pressure

- Improper wheel alignment
- Out-of-balance wheel
- Severe braking

After rotation, inflate all tyre pressures to specification (page 10-91) and inspect the wheel nuts for tightness.

CAUTION

Rotate unidirectional tyres and radial tyres that have an asymmetrical tread pattern or studs only from front to rear, not from side to side. Tyre performance will be reduced if rotated from side to side.

Replacing a Tyre or a Wheel

WARNING

Always use tyres that are in good condition.

Driving with worn tyres is dangerous. Reduced braking, steering, and traction could result in an accident.

Replace all four tyres at the same time.

Replacing just one tyre is dangerous. It could cause poor handling and poor braking resulting in loss of vehicle control. Mazda strongly recommends that you replace all four tyres at the same time.

Always use wheels of the correct size on your vehicle.

Using a wrong-sized wheel is dangerous. Braking and handling could be affected, leading to loss of control and an accident.

CAUTION

A wrong-sized wheel may adversely affect:

- Tyre fit
- Wheel and bearing life
- Ground clearance
- Snow-chain clearance
- Speedometer calibration
- Headlight aim
- Bumper height
- Tyre Pressure Monitoring System*

If a tyre wears evenly, a wear indicator will appear as a solid band across the tread.

Replace the tyre when this happens.

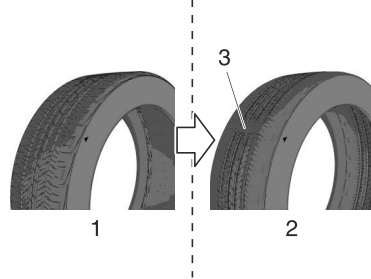

1. New tread
2. Worn tread
3. Tread wear indicator

You should replace the tyre before the band crosses the entire tread.

Inspecting the Emergency Flat Tyre Repair Kit

Inspect the emergency flat tyre repair kit at regular intervals.

- Check the tyre sealant period of effective use.
- Check the operation of the tyre compressor.

NOTE

The tyre sealant has a period of effective use. Check the period of effective use indicated on the bottle label and do not use it if it has expired. Have the tyre sealant replaced at an expert repairer (we recommend an Authorised Mazda Repairer) before the period of effective use has expired.

Replacing Light Bulbs

All the light bulbs are the LED type. The LED bulb cannot be replaced as a single unit because it is an integrated unit.

The LED bulb has to be replaced with the unit. If a replacement is necessary, consult an expert repairer (we recommend an Authorised Mazda Repairer).

Checking the Inspection Locations and Inspection Items

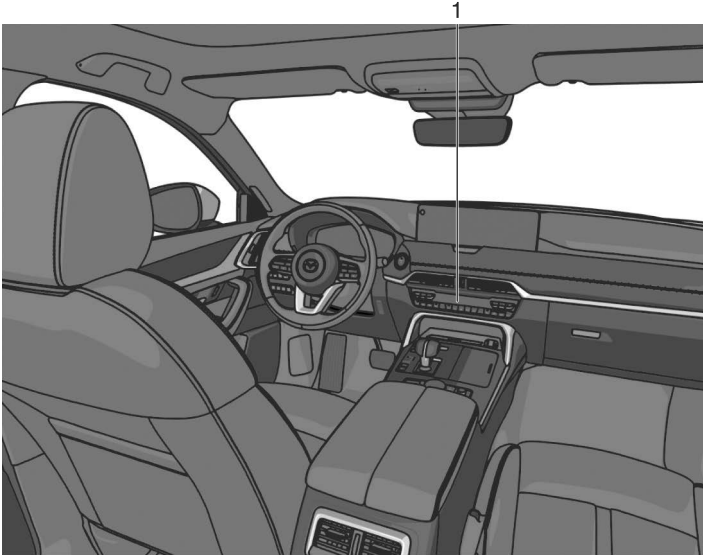

1. Air Conditioner

Air Conditioner Maintenance

Before Using the Air Conditioner

Lack of refrigerant may make the air conditioner less efficient. The refrigerant specifications are indicated on a label attached to the inside of the engine compartment. If the wrong type of refrigerant is used, it could result in a serious malfunction of the air conditioner. Consult a professional, government certified repairer for the inspection or repair because a special device is required for the air conditioner maintenance. For details, consult an expert repairer (we recommend an Authorised Mazda Repairer).

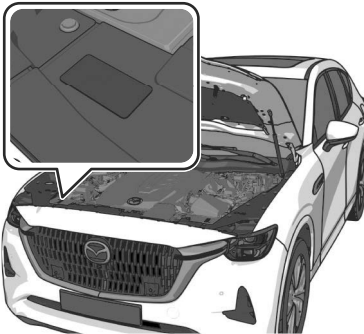

Air filter

An air filter with pollen and dust collecting function is equipped. To ensure safe and comfortable use of the air conditioner, have the air filter replaced periodically. For details, consult an expert repairer (we recommend an Authorised Mazda Repairer).

NOTE

- If the airflow of the air-conditioning system significantly decreases, the air filter may be clogged. Replace the air filter.
- If the vehicle is driven in areas with large amounts of dust and heavy traffic such as in large cities and cold regions, the air filter may need to be replaced more frequently.

Key Inspection

Warning And Caution about Key Replacement

⚠ CAUTION

- Make sure the battery is installed correctly. Battery leakage could occur if it is not installed correctly.
- When replacing the battery, be careful not to touch any of the internal circuitry and electrical terminals, bend the electrical terminals, or get dirt in the transmitter as the transmitter could be damaged.
- There is the danger of explosion if the battery is not correctly replaced.
- Dispose of used batteries according to the following instructions.
 - Insulate the plus and minus terminals of the battery using cellophane or equivalent tape.
 - Never disassemble.
 - Never throw the battery into fire or water.
 - Never deform or crush.
 - Replace only with the same type battery (CR2032 or equivalent).

Replacing the Key Battery

Replace with a new battery before the key becomes unusable.

The following conditions indicate that the battery power is low:

- The KEY indicator light (green) flashes in the instrument cluster.
- The system does not operate and the operation indicator light on the transmitter does not flash when the buttons are pressed.
- The system's operational range is reduced.

Incorrect battery replacement operation may damage the key. Replacing the battery at an expert repairer (we recommend an Authorised Mazda Repairer) is recommended.

If replacing the battery by yourself, heed the following instructions.

1. Remove the lower cover while pressing the knob in the direction of the arrow.

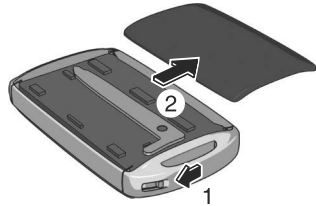

2. Press in the tab to unlock the upper cover.

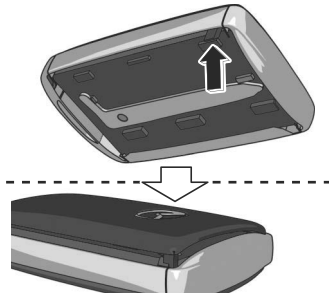

3. Insert a tape-wrapped flathead screwdriver into the gap and slide it.

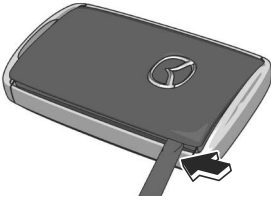

4. Twist the flathead screwdriver and remove the upper cover.

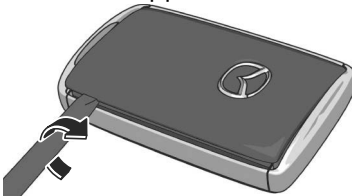

5. Remove the cap using the tape-wrapped flathead screwdriver.

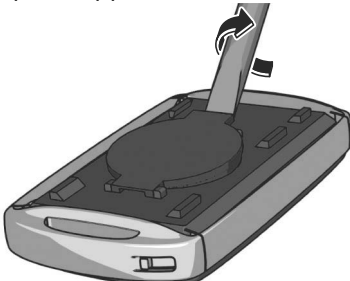

6. Remove the battery using the tape-wrapped flathead screwdriver.

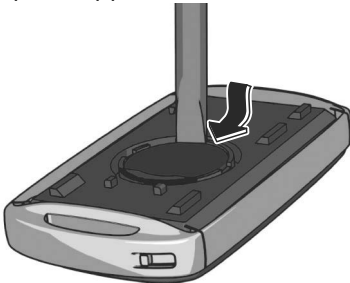

7. Insert a new battery into the key so that the positive pole is facing up.

8. Install the cap.

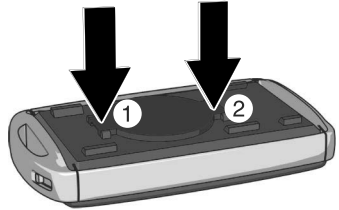

9. Install the upper cover.



10. Attach the lower cover so that its tabs are inserted into the slots of the key.

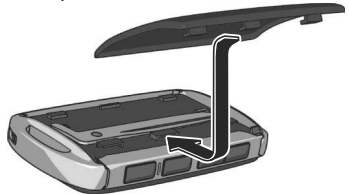

Exterior Maintenance

WARNING

Dry off brakes that have become wet by driving slowly, releasing the accelerator pedal and lightly applying the brakes several times until the brake performance returns to normal.

Driving with wet brakes is dangerous. Increased stopping distance or the vehicle pulling to one side when braking could result in a serious accident. Light braking will indicate whether the brakes have been affected.

CAUTION

- Before lifting the windscreen wiper blades off the windscreen, always follow the procedure for moving the windscreen wiper blades. Otherwise, a wiper blade, wiper arm, or the bonnet could be damaged. Refer to the Replacing Windscreen Wiper Blade Rubbers section (page 9-48) for the procedure on how to move the windscreen wiper blades to the service position.
- When the vehicle power is switched ON and the wiper lever is in the AUTO position, the windscreen wipers may operate automatically in the following cases:
 - The area of the windscreen above the rain sensor is touched or wiped with a cloth.
 - The windscreen or the rain sensor area in the cabin is hit.

When the vehicle power is switched ON and the wiper lever is in the AUTO position, do not touch the windscreen or the windscreen wipers. Otherwise, the windscreen wipers will operate automatically which could catch your fingers or damage the windscreen wipers.

When removing ice or snow, or cleaning the windscreen, always make sure the wiper lever is in the OFF position.

- Do not spray water in the engine compartment. Otherwise, it could result in engine-starting problems or damage to electrical parts.
- When washing and waxing the vehicle, be careful not to apply excessive force to any single area of the vehicle roof. Otherwise, you could dent the vehicle.
- Make sure that the fuel-filler flap is closed and lock the doors. Otherwise, the fuel-filler flap may be forcefully opened by water pressure causing damage to the vehicle or fuel-filler flap.
- **(Vehicles with hands-free liftgate)** When washing or waxing the vehicle, turn off the hands-free liftgate using the Mazda Connect or do not bring the transmitter into the area around the liftgate. Otherwise, the liftgate could open unexpectedly resulting in an accident. Refer to Power Liftgate section (page 4-21).
- Do not use steel wool, abrasive cleaners, or strong detergents containing highly alkaline or caustic agents on chrome-plated or anodised aluminium parts. This may damage the protective coating; also, cleaners and detergents may discolour or deteriorate the paint.

- If organic solvents such as petrol, oil, engine coolant, or battery fluid, get on the exterior, wipe it off immediately.
- Do not use wax containing compounds, organic solvents such as petrol or benzene, alcohols, acidic or alkaline detergents, or bleach for cleaning.

Wheel Maintenance

CAUTION

- If there is seawater or anti-freezing agent on the wheels, wash it off with water as soon as possible.
- Do not use any detergent other than mild detergent. Before using any detergent, verify the ingredients. Otherwise, the product could discolour or stain the aluminium wheels.

Interior Maintenance

WARNING

Do not spray water into the vehicle cabin.

Spraying water into the vehicle cabin is dangerous as electrical devices such as the audio and switches could get wet resulting in a malfunction or vehicle fire.

CAUTION

- Do not use polishing agents. Depending on the product ingredients, they could cause discolouration, stains, cracks or peeling of the coating.
- Do not scrape or scratch the inside of the window glass. It could damage the thermal filaments and the aerial lines.
- When washing the inside of the window glass, use a soft cloth dampened in lukewarm water, gently wiping the thermal filaments and the aerial lines. Use of glass cleaning products could damage the thermal filaments and the aerial lines.
- If liquid such as fragrance is spilled on the interior, wipe it off immediately.
- Do not use wax containing compounds, organic solvents such as petrol or benzene, alcohols, acidic or alkaline solvents, or bleach for cleaning.
- Do not try to rub off the shiny surface panels and the metallic parts with a dry cloth. Otherwise, it may cause scratches.

Instrument Panel Top (Soft pad) Maintenance

Instrument panel maintenance for areas requiring further cleaning.

1. Wipe the soiled area with a soft cloth soaked in a mild detergent diluted with water.
2. Wipe off any detergent and water remaining on the surface using a cloth soaked in water and wrung out well.

Upholstery and Synthetic Leather Maintenance

Fabric

1. Clean the soiled area by lightly dabbing it with a soft cloth soaked in a mild detergent (approx. 5 %) diluted with water.
2. Wipe off the remaining detergent using a cloth soaked in clean water and wrung out well.

Synthetic leather

1. Remove dust and sand using a vacuum cleaner.
2. Wipe the soiled area with a soft cloth soaked in a mild detergent (approx. 5 %) diluted with water.
3. Wipe off the remaining detergent using a cloth soaked in clean water and wrung out well.

Leather Upholstery Maintenance

1. Remove dust and sand using a vacuum cleaner.
2. Wipe off the soiled area with a soft cloth and a suitable, special cleaner or a soft cloth soaked in a mild detergent (about 5%) diluted with water.
3. Wipe off the remaining detergent using a cloth soaked in clean water and wrung out well.
4. Remove moisture with a dry, soft cloth and allow the leather to further dry in a well-ventilated, shaded area. If the leather gets wet such as from rain, remove the moisture and dry it as soon as possible.

NOTE

- Because genuine leather is a natural material, its surface is not uniform and it may have natural scars, scratches, and wrinkles.
- To maintain the quality for as long as possible, periodical maintenance, about twice a year, is recommended.
- If the leather upholstery comes into contact with any of the following, clean it immediately.
Leaving it uncleaned could cause premature wear, mold, or stains.
 - Sand or dirt
 - Grease or oil, such as hand cream
 - Alcohol, such as in cosmetic or hair dressing items
- If the leather upholstery gets wet, promptly remove moisture with a dry cloth. Remaining moisture on the surface may cause deterioration such as hardening and shrinkage.

Interior Maintenance

- Exposure to direct sunlight for long periods may cause deterioration and shrinkage. When parking the car under direct sunlight for long periods, shade the interior using sunshades.
- Do not leave vinyl products on the leather upholstery for long periods. They may affect the leather quality and colouring. If the cabin temperature becomes hot, the vinyl may deteriorate and adhere to the genuine leather.

Maintenance of the Dust-proof Sheet of the Active Driving Display

 **CAUTION**

Do not use detergent to clean the dust-proof sheet. In addition, if a chemical agent gets on the dust-proof sheet, wipe it off immediately. Otherwise, the coating may be damaged.

1. Wipe with a fine, soft cloth such as those used for cleaning eyeglasses.

Seat Belt Maintenance

WARNING

If a seat belt appears frayed or has abrasions, have it replaced by an expert repairer (we recommend an Authorised Mazda Repairer).

If a seat belt is used under such a condition, it cannot function at its full capacity which could result in serious injury or death.

Use a mild detergent to remove soiling from a seat belt.

If organic solvents are used for cleaning the seat belts or they become stained or bleached, there is the possibility of them becoming weakened and as a result, they may not function at their full capacity which could cause serious injury or death.

Do not disassemble, modify, or replace a seat belt.

If a seat belt is used under such a condition, it cannot function at its full capacity which could result in serious injury or death.

Always have your vehicle inspected by an expert repairer (we recommend an Authorised Mazda Repairer) if the vehicle has been involved in an accident.

Seat belts with the pretensioner system and the seat belts with the load-limiter system cannot be reused once they have operated (deployed).

If a seat belt is used under such a condition, it cannot function at its full capacity which could result in serious injury or death.

Always consult an expert repairer (we recommend an Authorised Mazda Repairer) when scrapping the vehicle. If the pretensioner system operates (deploys) unexpectedly, it could result in serious injury or death.

Do not repair the pretensioner system parts or wiring harnesses and do not attempt diagnose the pretensioner system circuits using an electrical tester or similar device.

Otherwise, they may not function normally or they may operate incorrectly, which could result in serious injury or death.

Check periodically that the seat belt systems work properly and are not damaged.

1. Lightly tap with a mild detergent to remove dirt.
2. Wipe with a thoroughly wrung cloth.
3. Allow to dry.
4. Make sure that the seat belt locks when it is pulled rapidly. If it is still not retracting properly, have it inspected at an expert repairer (we recommend an Authorised Mazda Repairer).

NOTE

Clean seat belts diligently if they get dirty. Leaving them uncleaned will make it difficult to clean them later, and it may affect the smooth retracting of the seat belt.

MEMO

10 Specifications/ Customer Information

Warranty.....	10-2	Information on Disposal in the European Union.....	10-75
Registering Your Vehicle in A Foreign Country.....	10-2	Information on Disposal in Other Countries Outside the European Union.....	10-76
Add-On Non-Genuine Parts and Accessories.....	10-2		
Cell Phones.....	10-3	Identification Numbers.....	10-77
Cell Phones Warning.....	10-3	Vehicle Identification Number (South Africa, Arab Gulf Cooperation Council, Iraq, Ghana).....	10-77
Declaration of Conformity.....	10-4	Model Plate.....	10-77
Keyless Entry System/Immobilizer System.....	10-4	Chassis Number/Vehicle Identification Number.....	10-78
Tyre Pressure Monitoring System.....	10-8	Vehicle Emission Control Information Label (Philippines).....	10-78
Front Radar Sensor System.....	10-10	Tyre Pressure Label.....	10-79
Front Side Radar/Rear Side Radar System.....	10-21	Engine Number.....	10-79
Audio System.....	10-24	Conformity Plate (Arab Gulf Cooperation Council, Iraq).....	10-80
Radio System.....	10-34		
Emergency Call System.....	10-43	Vehicle Specification.....	10-81
Mazda ERA-GLONASS.....	10-72	Engine.....	10-81
Wireless Charger (Qi).....	10-73	Mazda M Hybrid Boost Battery (e-SKYACTIV D).....	10-82
Electromagnetic Compatibility.....	10-74	Electrical System.....	10-83
Electromagnetic Compatibility.....	10-74	Lubricant Quality.....	10-84
Collection/Disposal of Old Equipment/Used Battery.....	10-75	Cleaner.....	10-86
Information for Users on Collection and Disposal of Old Equipment and Used Batteries.....	10-75	Capacities.....	10-87
		Dimensions.....	10-89
		Light Bulbs.....	10-90
		Tyres.....	10-91
		Brakes.....	10-93

Registering Your Vehicle in A Foreign Country

Registering your vehicle in a foreign country may be problematic depending on whether it meets the specific emission and safety standards of the country in which the vehicle will be driven. Consequently, your vehicle may require modifications at personal expense in order to meet the regulations.

In addition, you should be aware of the following issues:

Satisfactory vehicle servicing may be difficult or impossible in another country.

The fuel specified for your vehicle may be unavailable.

Parts, servicing techniques, and tools necessary to maintain and repair your vehicle may be unavailable.

There might not be an expert repairer (we recommend an Authorised Mazda Repairer) in the country you plan to take your vehicle.

The Mazda warranty is valid only in certain countries.

Add-On Non-Genuine Parts and Accessories

Please note that technical alterations to the original state of your Mazda vehicle can affect the safety of the vehicle. Such technical alterations include not only the use of unsuitable spare parts, but also accessories, fittings or attachments, including rims and tyres.

Genuine Mazda Parts and Genuine Mazda Accessories have been specifically designed for Mazda vehicles.

Other parts and accessories than those mentioned above have not been examined and approved by Mazda unless explicitly stated by Mazda. We cannot certify the suitability of such products. Mazda is not liable for any damage caused by the use of such products.

WARNING

Be very careful in choosing and installing add-on electrical equipment, such as mobile telephones, two-way radios, stereo systems, and car alarm systems.

Incorrectly choosing or installing improper add-on equipment or choosing an improper installer is dangerous. Essential systems could be damaged, causing engine stalling, air-bag (SRS) activation, ABS/TCS/DSC inactivation, or a fire in the vehicle.

Mazda assumes no responsibility for death, injury, or expenses that may result from the installation of add-on non-genuine parts or accessories.

Cell Phones Warning

WARNING

Please comply with the legal regulations concerning the use of communication equipment in vehicles in your country.

Use of any electrical devices such as cell phones, computers, portable radios, vehicle navigation or other devices by the driver while the vehicle is moving is dangerous. Dialing a number on a cell phone while driving also ties-up the driver's hands. Use of these devices will cause the driver to be distracted and could lead to a serious accident. If a passenger is unable to use the device, pull off the right-of-way to a safe area before use. If use of a cell phone is necessary despite this warning, use a hands-free system to at least leave the hands free to drive the vehicle. Never use a cell phone or other electrical devices while the vehicle is moving and, instead, concentrate on the full-time job of driving.

Declaration of Conformity

Keyless Entry System/Immobilizer System

[EN] English	Hereby, MITSUBISHI ELECTRIC CORPORATION, HIMEJI WORKS, declares that the radio equipment type Keyless System (SKE11E-01, SKE114-01, SKE116-01) is in compliance with Directive 2014/53/EU.
[BG] Bulgarian	С настоящото MITSUBISHI ELECTRIC CORPORATION, HIMEJI WORKS декларира, че този тип радиосъоръжение Keyless System (SKE11E-01, SKE114-01, SKE116-01) е в съответствие с Директива 2014/53/ЕС.
[ES] Spanish	Por la presente, MITSUBISHI ELECTRIC CORPORATION, HIMEJI WORKS declara que el tipo de equipo radioeléctrico Keyless System (SKE11E-01, SKE114-01, SKE116-01) es conforme con la Directiva 2014/53/UE.
[CS] Czech	Tímto MITSUBISHI ELECTRIC CORPORATION, HIMEJI WORKS prohlašuje, že typ rádiového zařízení Keyless System (SKE11E-01, SKE114-01, SKE116-01) je v souladu se směrnicí 2014/53/EU.
[DA] Danish	Hermed erklærer MITSUBISHI ELECTRIC CORPORATION, HIMEJI WORKS, at radioudstyrtypen Keyless System (SKE11E-01, SKE114-01, SKE116-01) er i overensstemmelse med direktiv 2014/53/EU.
[DE] German	Hiermit erkläre MITSUBISHI ELECTRIC CORPORATION, HIMEJI WORKS, dass der Funkanlagentyp Keyless System (SKE11E-01, SKE114-01, SKE116-01) der Richtlinie 2014/53/EU entspricht.
[ET] Estonian	Käesolevaga deklareerib MITSUBISHI ELECTRIC CORPORATION, HIMEJI WORKS, et käesolev raadioseadme tüüp Keyless System (SKE11E-01, SKE114-01, SKE116-01) vastab direktiivi 2014/53/EL nõuetele.
[EL] Greek	Με την παρούσα ο/η MITSUBISHI ELECTRIC CORPORATION, HIMEJI WORKS, δηλώνει ότι ο ραδιοεξοπλισμός Keyless System (SKE11E-01, SKE114-01, SKE116-01) πληροί την οδηγία 2014/53/ΕΕ.
[FR] French	Le soussigné, MITSUBISHI ELECTRIC CORPORATION, HIMEJI WORKS, déclare que l'équipement radioélectrique du type Keyless System (SKE11E-01, SKE114-01, SKE116-01) est conforme à la directive 2014/53/UE.
[HR] Croatian	MITSUBISHI ELECTRIC CORPORATION, HIMEJI WORKS ovime izjavljuje da je radijska oprema tipa Keyless System (SKE11E-01, SKE114-01, SKE116-01) u skladu s Direktivom 2014/53/EU.
[IT] Italian	Il fabbricante, MITSUBISHI ELECTRIC CORPORATION, HIMEJI WORKS, dichiara che il tipo di apparecchiatura radio Keyless System (SKE11E-01, SKE114-01, SKE116-01) è conforme alla direttiva 2014/53/UE.
[LV] Latvian	Ar šo MITSUBISHI ELECTRIC CORPORATION, HIMEJI WORKS deklarē, ka radioiekārta Keyless System (SKE11E-01, SKE114-01, SKE116-01) atbilst Direktīvai 2014/53/ES.
[LT] Lithuanian	As, MITSUBISHI ELECTRIC CORPORATION, HIMEJI WORKS, patvirtinu, kad radijo įrenginių tipas Keyless System (SKE11E-01, SKE114-01, SKE116-01) atitinka Direktyvą 2014/53/ES.
[HU] Hungarian	MITSUBISHI ELECTRIC CORPORATION, HIMEJI WORKS igazolja, hogy a Keyless System (SKE11E-01, SKE114-01, SKE116-01) típusú rádióberendezés megfelel a 2014/53/EU irányelvnek.
[MT] Maltese	B'dan, MITSUBISHI ELECTRIC CORPORATION, HIMEJI WORKS, niddikjara li dan it-tip ta' tagħmir tar-radju Keyless System (SKE11E-01, SKE114-01, SKE116-01) huwa konformi mad-Direttiva 2014/53/UE.
[NL] Dutch	Hierbij verklaar ik, MITSUBISHI ELECTRIC CORPORATION, HIMEJI WORKS, dat het type radioapparaatuur Keyless System (SKE11E-01, SKE114-01, SKE116-01) conform is met Richtlijn 2014/53/EU.
[PL] Polish	MITSUBISHI ELECTRIC CORPORATION, HIMEJI WORKS niniejszym oświadczam, że typ urządzenia radiowego Keyless System (SKE11E-01, SKE114-01, SKE116-01) jest zgodny z dyrektywą 2014/53/UE.
[PT] Portuguese	O abaixo assinado MITSUBISHI ELECTRIC CORPORATION, HIMEJI WORKS declara que o presente tipo de equipamento de rádio Keyless System (SKE11E-01, SKE114-01, SKE116-01) está em conformidade com a Diretiva 2014/53/UE.
[RO] Romanian	Prin prezenta, MITSUBISHI ELECTRIC CORPORATION, HIMEJI WORKS declară că tipul de echipamente radio Keyless System (SKE11E-01, SKE114-01, SKE116-01) este în conformitate cu Directiva 2014/53/UE.

[SK] Slovak	MITSUBISHI ELECTRIC CORPORATION, HIMEJI WORKS týmto vyhlasuje, že rádiové zariadenie typu Keyless System (SKE11E-01, SKE114-01, SKE116-01) je v súlade so smernicou 2014/53/EÚ.
[SL] Slovenian	MITSUBISHI ELECTRIC CORPORATION, HIMEJI WORKS potrjuje, da je tip radijske opreme Keyless System (SKE11E-01, SKE114-01, SKE116-01) skladen z Direktivo 2014/53/EU.
[FI] Finnish	MITSUBISHI ELECTRIC CORPORATION, HIMEJI WORKS vakuuttaa, että radiolaitetyyppi Keyless System (SKE11E-01, SKE114-01, SKE116-01) on direktiivin 2014/53/EU mukainen.
[SV] Swedish	Härmed försäkras MITSUBISHI ELECTRIC CORPORATION, HIMEJI WORKS att denna typ av radioutrustning Keyless System (SKE11E-01, SKE114-01, SKE116-01) överensstämmer med direktiv 2014/53/EU.

The full text of the EU declaration of conformity is available at the following internet address: <http://www.mitsubishielectric.com/bu/automotive/doc/re.html>

UK



[EN] English	Hereby, MITSUBISHI ELECTRIC CORPORATION, HIMEJI WORKS, declares that the radio equipment type Keyless System (SKE11E-01, SKE114-01, SKE116-01) is in compliance with the relevant statutory requirements. The full text of the EU declaration of conformity is available at the following internet address: http://www.mitsubishielectric.com/bu/automotive/doc/ukgb.html
-----------------	--

Manufacturer: MITSUBISHI ELECTRIC CORPORATION, HIMEJI WORKS
 840, Chiyoda-machi, Himeji, Hyogo 670-8677, Japan

Model: SKE11E-01

Operation frequency : 433.92 MHz

Maximum output power : 10mW

Model: SKE114-01

Operation frequency : 125 kHz

Maximum output power: 107dB μ V/m at 10 meters

Model: SKE116-01

Operation frequency : 433.92 MHz

CAUTION - Danger of explosion if battery is incorrectly replaced.

Replace only with the same or equivalent type.

Please check and obey all local laws and regulations for the disposal of batteries or accumulations.

Never dispose of battery in fire or mechanical crushing or cutting.

If battery is incorrectly discarded or heated to high temperature (100 °C(212°F) or higher), gas may be generated inside battery, causing electrolyte leak, internal short circuit, heat generation, explosion and violent flaring.

CAUTION - Do not expose Hand Unit to excessive heat such as sunshine, fire or the like.

WARNING

Do not ingest the battery, Chemical Burn Hazard

This product contains a coin/button cell battery. If the coin/button cell battery is swallowed, it can cause severe internal burns in just 2 hours and can lead to death. Keep new and used batteries away from children. If the battery compartment does not close securely, stop using the product and keep it away from children. If you think batteries might have been swallowed or placed inside any part of the body, seek immediate medical attention.

The caution mark of ISO 7000-0434 is located on the internal case.



This symbol is intended to alert the user to the presence of important operating and maintenance (servicing) instructions in the literature accompanying the appliance.

Declaration of Conformity

Moldova	<p>Prin prezenta, MITSUBISHI ELECTRIC CORPORATION, HIMEJI WORKS declară că tipul de echipamente radio (SKE11E-01, SKE114-01, SKE116-01) este în conformitate cu Reglementarea tehnică „Punerea la dispoziție pe piață a echipamentelor radio”.</p> <p>Textul integral al declarației de conformitate este disponibil la următoarea adresă de Internet: http://www.mitsubishielectric.com/bu/automotive/doc/mda.html</p>
Україна	<p>справжнім MITSUBISHI ELECTRIC CORPORATION, HIMEJI WORKS заявляє, що тип радіобладнання (SKE11E-01, SKE114-01) відповідає Технічному регламенту радіобладнання.</p> <p>Повний текст декларації про відповідність доступний на веб-сайті за такою адресою: http://www.mitsubishielectric.com/bu/automotive/doc/ukr.html</p>
Беларусь	<p>Назва прадукту: Сістэма бязключавога доступу</p> <p>Мэта выкарыстання: замыканне або разблакоўка дзвярэй аўтамабіля і запуск рухавіка</p> <p>Радые спецыфікацыя</p> <p>Прымперадатчык</p> <ul style="list-style-type: none"> - Мадэль: SKE11E-01 - Рабочая частата: 433,92 МГц - Максімальная магутнасць: 10 мВт <p>Прымёнік</p> <ul style="list-style-type: none"> - Мадэль: SKE116-01 - Рабочая частата: 433,92 МГц <p>Устаноўка: устаноўлена ў транспартным сродку</p> <p>Правілы і інфармацыя аб бяспецы выкарыстання: апісаны ў гэтым кіраўніцтве</p> <p>Спосаб рамонту: звязаныся з пакупніком транспартнага сродку</p> <p>Вытворца: MITSUBISHI ELECTRIC CORPORATION, HIMEJI WORKS 840, Chiyoda-machi, Himeji, Hyogo 670-8677, Japan</p> <p>Мясцовы прадстаўнік-агент</p> <ul style="list-style-type: none"> - Кампанія: Friendly LLC - Адрас: 220007, г. Мінск, вул. Валадзько, 6, Рэспубліка Беларусь - Тэлефонны нумар: + 375 17 2205545 - Кантактная асоба: Aleksey Moroz - Эл. Пошта: moroz.aleksey@friendly.by <p>Дата вырабу: Паказець на прадукце</p>

FCC CAUTION

Changes or modifications not expressly approved by the party responsible for compliance could void the user's authority to operate the equipment.

FCC

















This device complies with Part 15 of the FCC Rules. Operation is subject to the following two conditions: (1) this device may not cause harmful interference, and (2) this device must accept any interference received, including interference that may cause undesired operation.

This product has been Type Approved by Jamaica: SMA -SKE11D-01 / SKE114-01 / SKE115-01.

低功率射頻器材技術規範

『取得審驗證明之低功率射頻器材，非經核准，公司、商號或使用者均不得擅自變更頻率、加大功率或變更原設計之特性及功能。
低功率射頻器材之使用不得影響飛航安全及干擾合法通信；經發現有干擾現象時，應立即停用，並改善至無干擾時方得繼續使用。
前述合法通信，指依電信管理法規定作業之無線電通信。
低功率射頻器材須忍受合法通信或工業、科學及醫療用電波輻射性電機設備之干擾。』

Keyless System Radio approval Marking

<p>Complies with IMDA Standards DA100926</p>												
<table border="1" style="width: 100%; border-collapse: collapse;"> <tr> <td style="text-align: center;">Oman - TRA</td> </tr> <tr> <td style="text-align: center;">D090024</td> </tr> <tr> <td>R/5590/18:SKE11E-01</td> </tr> <tr> <td>R/5655/18:SKE114-01</td> </tr> <tr> <td>R/5659/18:SKE116-01</td> </tr> </table>	Oman - TRA	D090024	R/5590/18:SKE11E-01	R/5655/18:SKE114-01	R/5659/18:SKE116-01	<p>BOCRA REGISTERED No: BOCRA/TA/2020/3919:SKE11E-01 BOCRA/TA/2020/3918:SKE114-01 BOCRA/TA/2020/3917:SKE116-01</p>						
Oman - TRA												
D090024												
R/5590/18:SKE11E-01												
R/5655/18:SKE114-01												
R/5659/18:SKE116-01												
<table style="width: 100%;"> <tr> <td style="text-align: center;">SKE11E-01</td> <td style="text-align: center;">SKE118-01</td> <td style="text-align: center;">SKE114-01</td> <td style="padding-left: 20px;">Ghana</td> </tr> <tr> <td style="text-align: center;"></td> <td style="text-align: center;"></td> <td style="text-align: center;"></td> <td style="padding-left: 20px;"> SKE11E-01 NCA APPROVED: BR3-HS-GE2-05A SKE114-01 NCA APPROVED: BR3-1M-GE2-05B </td> </tr> </table>	SKE11E-01	SKE118-01	SKE114-01	Ghana				SKE11E-01 NCA APPROVED: BR3-HS-GE2-05A SKE114-01 NCA APPROVED: BR3-1M-GE2-05B				
SKE11E-01	SKE118-01	SKE114-01	Ghana									
			SKE11E-01 NCA APPROVED: BR3-HS-GE2-05A SKE114-01 NCA APPROVED: BR3-1M-GE2-05B									
<table style="width: 100%;"> <tr> <td style="text-align: center;">  NR: 2021-02-10-070 Model: SKE11E-01 NR: 2021-02-10-071 Model: SKE114-01 </td> </tr> </table>					 NR: 2021-02-10-070 Model: SKE11E-01 NR: 2021-02-10-071 Model: SKE114-01							
 NR: 2021-02-10-070 Model: SKE11E-01 NR: 2021-02-10-071 Model: SKE114-01												

Nigeria

**Connection and use of this communications
 equipment is permitted by the Nigerian
 Communications Commission**

Israel

51-80389(SKE11E-01) - "מספר אישור התאמה מטעם משרד התקשורת";
 51-79883(SKE114-01) - "מספר אישור התאמה מטעם משרד התקשורת";
 51-80851(SKE116-01) - "מספר אישור התאמה מטעם משרד התקשורת";
 "חל איסור לבצע פעולות במכשיר אשר יש בהן כדי לשנות את תכונותיו
 האלחוטיות של המכשיר, ובכלל זה החלפת אנטנה מקורית או החלפת
 אפשרות לחיבור לאנטנה חיצונית ללא קבלת אישור משרד התקשורת,
 בשל החשש להפרעות אלחוטיות".

Declaration of Conformity

Tyre Pressure Monitoring System

[EU, Ukraine]

<https://continental-homologation.com/mazda>

[Taiwan]

低功率電波輻射性電機管理辦法

第十二條 經型式認證合格之低功率射頻電機，非經許可，公司、商號或使用者均不得擅自變更頻率、加大功率或變更原設計之特性及功能。

第十四條 低功率射頻電機之使用不得影響飛航安全及干擾合法通信；經發現有干擾現象時，應立即停用，並改善至無干擾時方得繼續使用。前項合法通信，指依電信法規定作業之無線電通信。低功率射頻電機須忍受合法通信或工業、科學及醫療用電波輻射性電機設備之干擾。

[Moldova]



[Jordan]

Manufacturer Name : Continental Automotive GmbH
Model, Type Number : TIS-15
Serial Number
TRC type approval's number : TRC/LPD/2017/560

[UAE]

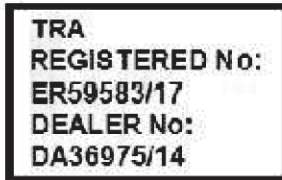

[Indonesia]



[Russia]



[Serbia]



Декларация о соответствии ТР ТС 020/2011 ЕАЭС № RU Д-DE.ЭМ03.В.00148 от 05.03.2018, действительна по 04.03.2023, зарегистрирована органом по сертификации продукции ФГУП Ордена Трудового Красного Знамени научно-исследовательский институт радио «Испытательный центр «Омега»

[Israel]

- א. השימוש במכשיר הוא על בסיס "משני" ופטור מרישיון הפעלה אלחוטי. כלומר - לא מוגן מהפרעות, וללא הפר למערכות אחרות.
- ב. רק "בפעולות בדיקה" לשימוש עצמי של הלקוח בלבד, הציוד פטור מרישיון הפעלה אלחוטי. מתן "שרות בדיקה" לצד ג' מחייב רישיון מיוחד ממשרד התקשורת
- ג. אסור להחליף את האנטנה המקורית של המכשיר, ולא לעשות בו כל שינוי טכני אחר.

Declaration of Conformity

Front Radar Sensor System

EU

Manufacturer Postal Address

	ADC Automotive Distance Control Systems GmbH Peter-Dornier-Strasse 10, 88131 Lindau, Germany
--	---

01_RED_BG_Bulgarian

ОПРОСТЕНА ЕС ДЕКЛАРАЦИЯ ЗА СЪОТВЕТСТВИЕ	С настоящото ADC Automotive Distance Control Systems GmbH декларира, че този тип радиосъоръжение ARS 4-B е в съответствие с Директива 2014/53/ЕС. Цялостният текст на ЕС декларацията за съответствие може да се намери на следния интернет адрес: http://continental.automotive-approvals.com/
	радиочестотната лента или ленти, в която или които работи радиосъоръжението: 76–77 GHz
	максималната радиочестотна мощност, излъчвана в радиочестотната лента или ленти, в която или които работи радиосъоръжението.: 3.16W (35dBm RMS EIRP)

02_RED_ES_Spanish

DECLARACIÓN UE DE CONFORMIDAD SIMPLIFICADA	Por la presente, ADC Automotive Distance Control Systems GmbH declara que el tipo de equipo radioeléctrico ARS 4-B es conforme con la Directiva 2014/53/UE. El texto completo de la declaración UE de conformidad está disponible en la dirección Internet siguiente: http://continental.automotive-approvals.com/
	Banda o bandas de frecuencia en las que opera el equipo radioeléctrico: 76–77 GHz
	Potencia máxima de radiofrecuencia transmitida en la banda o bandas de frecuencia en las que opera el equipo radioeléctrico: 3.16W (35dBm RMS EIRP)

03_RED_CS_Czech

ZJEDNODUŠENÉ EU PROHLÁŠENÍ O SHODĚ	Tímto ADC Automotive Distance Control Systems GmbH prohlašuje, že typ rádiového zařízení ARS 4-B je v souladu se směrnicí 2014/53/EU. Úplné znění EU prohlášení o shodě je k dispozici na této internetové adrese: http://continental.automotive-approvals.com/
	Kmitočtové pásmo (kmitočtová pásma), v němž (v nichž) rádiové zařízení pracuje: 76–77 GHz
	Maximální radiofrekvencní výkon vysílaný v kmitočtovém pásmu (v kmitočtových pásmech), v němž (v nichž) je rádiové zařízení provozováno: 3.16W (35dBm RMS EIRP)

04_RED_DA_Danish

FORENKLET EU- OVERENSSTEMMELSE SERKLÆRING	Hiermed erklærer ADC Automotive Distance Control Systems GmbH, at radioudstyrstypen ARS 4-B er i overensstemmelse med direktiv 2014/53/EU. EU-overensstemmelseserklæringens fulde tekst kan findes på følgende internetadresse: http://continental.automotive-approvals.com/
	Frekvensbånd, som radioudstyret fungerer på: 76–77 GHz
	Maksimal radiofrekvenseffekt, der udsendes i de frekvensbånd, som radioudstyret fungerer på: 3.16W (35dBm RMS EIRP)

05_RED_DE_German

VEREINFACHTE EU- KONFORMITÄTSEK- KLÄRUNG	Hiermit erklärt ADC Automotive Distance Control Systems GmbH, dass der Funkanlagentyp ARS 4-B der Richtlinie 2014/53/EU entspricht. Der vollständige Text der EU-Konformitätserklärung ist unter der folgenden Internetadresse verfügbar: http://continental.automotive-approvals.com/
	Das Frequenzband oder die Frequenzbänder, in dem bzw. denen die Funkanlage betrieben wird: 76–77 GHz
	Die in dem Frequenzband oder den Frequenzbändern, in dem bzw. denen die Funkanlage betrieben wird, abgestrahlte maximale Sendeleistung: 3.16W (35dBm RMS EIRP)

06_RED_ET_Estonian

LIHTSUSTATUD ELI VASTAVUSDEKLARATSIOON	Käesolevaga deklareerib ADC Automotive Distance Control Systems GmbH, et käesolev raadioseadme tüüp ARS 4-B vastab direktiivi 2014/53/EÜ nõuetele. ELI vastavusdeklaratsiooni täielik tekst on kättesaadav järgmisel Internetiaadressil: http://continental.automotive-approvals.com/
	Sagedusriba(d), millel raadioseade töötab: 76–77 GHz
	Raadioseadme töösagedus(t)el edastatav maksimaalne saatevõimsus: 3.16W (35dBm RMS EIRP)

07_RED_EL_Greek

ΑΠΛΟΥΣΤΕΥΜΕΝΗ ΔΗΛΩΣΗ ΣΥΜΜΟΡΦΩΣΗΣ ΕΕ	Με την παρούσα ο/η ADC Automotive Distance Control Systems GmbH, δηλώνει ότι ο ραδιοεξοπλισμός ARS 4-B πληροί την οδηγία 2014/53/ΕΕ. Το πλήρες κείμενο της δηλώσης συμμόρφωσης ΕΕ διατίθεται στην ακόλουθη ιστοσελίδα στο διαδίκτυο: http://continental.automotive-approvals.com/
	Οι ζώνες συχνοτήτων στις οποίες λειτουργεί ο ραδιοεξοπλισμός: 76–77 GHz
	η μέγιστη ραδιοηλεκτρική ισχύς στις ζώνες συχνοτήτων στις οποίες λειτουργεί ο ραδιοεξοπλισμός: 3.16W (35dBm RMS EIRP)

08_RED_EN_English

SIMPLIFIED EU DECLARATION OF CONFORMITY	Hereby, ADC Automotive Distance Control Systems GmbH declares that the radio equipment type ARS 4-B is in compliance with Directive 2014/53/EU. The full text of the EU declaration of conformity is available at the following internet address: http://continental.automotive-approvals.com/
	Frequency band(s) in which the radio equipment operates: 76–77 GHz
	Maximum radio-frequency power transmitted in the frequency band(s) in which the radio equipment operates: 3.16W (35dBm RMS EIRP)

09_RED_FR_French

DECLARATION UE DE CONFORMITE SIMPLIFIEE	Le soussigné, ADC Automotive Distance Control Systems GmbH, déclare que l'équipement radioélectrique du type ARS 4-B est conforme à la directive 2014/53/UE. Le texte complet de la déclaration UE de conformité est disponible à l'adresse internet suivante: http://continental.automotive-approvals.com/
	Bandes de fréquences utilisées par l'équipement radioélectrique: 76–77 GHz
	Puissance de radiofréquence maximale transmise sur les bandes de fréquences utilisées par l'équipement radioélectrique: 3.16W (35dBm RMS EIRP)

11_RED_HR_Croatian

POJEDNOSTAVLJENA EU IZJAVA O SUKLADNOSTI	ADC Automotive Distance Control Systems GmbH ovime izjavljuje da je radijska oprema tipa ARS 4-B u skladu s Direktivom 2014/53/EU. Cjeloviti tekst EU izjave o sukladnosti dostupan je na sljedećoj Internetskoj adresi: http://continental.automotive-approvals.com/
	Frekvencijski pojas (frekvencijski pojasi) u kojem (kojima) radijska oprema radi: 76–77 GHz
	Najveća radiofrekvencijska snaga koja se prenosi u frekvencijskom pojasu (frekvencijskim pojasma) u kojem (kojima) radijska oprema radi: 3.16W (35dBm RMS EIRP)

12_RED_IT_Italian

DICHIARAZIONE DI CONFORMITÀ UE SEMPLIFICATA	Il fabbricante, ADC Automotive Distance Control Systems GmbH, dichiara che il tipo di apparecchiatura radio ARS 4-B è conforme alla direttiva 2014/53/UE. Il testo completo della dichiarazione di conformità UE è disponibile al seguente indirizzo Internet: http://continental.automotive-approvals.com/
	Bande di frequenza di funzionamento dell'apparecchiatura radio: 76–77 GHz
	Massima potenza a radiofrequenza trasmessa nelle bande di frequenza in cui opera l'apparecchiatura radio: 3.16W (35dBm RMS EIRP)

Specifications/Customer Information

Declaration of Conformity

13_RED_LV_Latvian

VĪENKĀRŠĒTA ES ATBILSTĪBAS DEKLARĀCIJA	Aš šo ADC Automotive Distance Control Systems GmbH deklarē, ka radioiekārta ARS 4-B atbilst Direktīvai 2014/53/ES. Plāns ES atbilstības deklarācijas teksts ir pieejams šādā interneta vietnē: http://continental.automotive-approvals.com/
	Frekvencu joslu(-as), kurā(-ās) radioiekārta darbojas: 76–77 GHz
	Frekvencu joslā(-ās), kurā(-ās) darbojas radioiekārta, maksimālo pārraidītā signāla jaudu.: 3.16W (35dBm RMS EIRP)

14_RED_LT_Lithuanian

SUPAPRĀSTĪNTA ES ATITIKTĪBAS DEKLARĀCIJA	Aš, ADC Automotive Distance Control Systems GmbH, patvirtinu, kad radioj ierīgu tipas ARS 4-B atbilst Direktīvai 2014/53/ES. Visas ES atitiktības deklarācijas teksts pieejams šīo interneta adresē: http://continental.automotive-approvals.com/
	Dažņu juosta (-os), kurioje (-iose) veikia radijo ierīginiai: 76–77 GHz
	Didžiausia radijo dažnių galia, perduodama toje (tose) dažnių juostoje (-ose), kurioje (-iose) veikia radijo ierīginiai: 3.16W (35dBm RMS EIRP)

15_RED_HU_Hungarian

EGYSZERŰSÍTETT EU-MEGFELELŐSÉGI NYILATKOZAT	ADC Automotive Distance Control Systems GmbH igazolja, hogy a ARS 4-B típusú rádióberendezés megfelel a 2014/53/EU irányelvnek. Az EU-megfelelőségi nyilatkozat teljes szövege elérhető a következő internetes címen: http://continental.automotive-approvals.com/
	Az(ok) a frekvenciasáv(ok), amely(ek)en a rádióberendezés működik: 76–77 GHz
	Az abban a frekvenciasávban vagy azokban a frekvenciasávokban továbbított maximális jelerősség, amely(ek)ben a rádióberendezés üzemel: 3.16W (35dBm RMS EIRP)

16_RED_MT_Maltese

DIKJARAZZJONI SSIMPLIFIKATA TA' KONFORMITÀ TAL-UE	B'dan, ADC Automotive Distance Control Systems GmbH, niddikjara li dan it-tip ta' tagħmir tar-radju ARS 4-B huwa konformi mad-Direttiva 2014/53/UE. It-test kollu tad-dikjarazzjoni ta' konformità tal-UE huwa disponibbli f'dan l-indirizz tal-Internet li ġej: http://continental.automotive-approvals.com/
	Il-medda/meded tal-frekwenza li jaħdem fihom it-tagħmir tar-radju: 76–77 GHz
	Il-potenza massima tal-frekwenza tar-radju trażmessa fil-medda/meded tal-frekwenza li jaħdem fihom it-tagħmir tar- radju: 3.16W (35dBm RMS EIRP)

17_RED_NL_Dutch

VEREENVOUDIGDE EU-CONFORMITEITSVERKLARING	Hierbij verklaar ik, ADC Automotive Distance Control Systems GmbH, dat het type radioapparaat ARS 4-B conform is met Richtlijn 2014/53/EU. De volledige tekst van de EU-conformiteitsverklaring kan worden geraadpleegd op het volgende internetadres: http://continental.automotive-approvals.com/
	Frequentieband(en) waarin de radioapparaat functioneert: 76–77 GHz
	Maximaal radiofrequent vermogen uitgezonden in de frequentieband(en) waarin de radioapparaat functioneert: 3.16W (35dBm RMS EIRP)

18_RED_PL_Polish

UPROSZCZONA DEKLARACJA ZGODNOŚCI UE	ADC Automotive Distance Control Systems GmbH niniejszym oświadcza, że typ urządzenia radiowego ARS 4-B jest zgodny z dyrektywą 2014/53/UE. Pełny tekst deklaracji zgodności UE jest dostępny pod następującym adresem internetowym: http://continental.automotive-approvals.com/
	Zakres(-ów) częstotliwości, w którym (których) pracuje urządzenie radiowe: 76–77 GHz

19_RED_PT_Portuguese

DECLARAÇÃO UE DE CONFORMIDADE SIMPLIFICADA	O(a) abaixo assinado(a) ADC Automotive Distance Control Systems GmbH declara que o presente tipo de equipamento de rádio ARS 4-B está em conformidade com a Diretiva 2014/53/UE. O texto integral da declaração de conformidade está disponível no seguinte endereço de Internet: http://continental.automotive-approvals.com/
	A(s) banda(s) de frequências em que o equipamento de rádio funciona: 76-77 GHz
	A potência máxima de radiofrequências transmitida na(s) banda(s) de frequências em que o equipamento de rádio funciona: 3.16W (35dBm RMS EIRP)

20_RED_RO_Romanian

DECLARAȚIA UE DE CONFORMITATE SIMPLIFICATA	Prin prezenta, ADC Automotive Distance Control Systems GmbH declară că tipul de echipamente radio ARS 4-B este în conformitate cu Directiva 2014/53/UE. Textul integral al declarației UE de conformitate este disponibil la următoarea adresă internet: http://continental.automotive-approvals.com/
	Banda (benzile) de frecvențe în care funcționează echipamentul radio: 76-77 GHz
	Puterea maximă de radiofrecvență transmisă în banda (benzile) de frecvențe în care funcționează echipamentul radio: 3.16W (35dBm RMS EIRP)

21_RED_SK_Slovak

ZJEDNODUŠENÉ EU VYHLASENIE O ZHODE	ADC Automotive Distance Control Systems GmbH týmto vyhlasuje, že rádiové zariadenie typu ARS 4-B je v súlade so smernicou 2014/53/EÚ. Úplné EU vyhlásenie o zhode je k dispozícii na tejto internetovej adrese: http://continental.automotive-approvals.com/
	Frekvenčné pásmo resp. pásma, v ktorých rádiové zariadenie pracuje: 76-77 GHz
	Maximálny vysokofrekvenčný výkon prenášaný vo frekvenčnom pásme, resp. pásmach, v ktorých rádiové zariadenie pracuje: 3.16W (35dBm RMS EIRP)

22_RED_SL_Slovenian

POENOSTAVLJENA IZJAVA EU O SKLADNOSTI	ADC Automotive Distance Control Systems GmbH potrjuje, da je tip radijske opreme ARS 4-B skladen z Direktivo 2014/53/EU. Celotno besedilo izjave EU o skladnosti je na voljo na naslednjem spletnem naslovu: http://continental.automotive-approvals.com/
	Frekvenčni pas ali pasovi, na katerih deluje radijska oprema: 76-77 GHz
	Največja energija za radijsko frekvenco, preneseno po frekvenčnem pasu ali pasovih, na katerih radijska oprema deluje: 3.16W (35dBm RMS EIRP)

23_RED_FI_Finnish

YKSINKERTAISTETTU EU-VAATIMUSTENMUKAISUUSVAKUUTUS	ADC Automotive Distance Control Systems GmbH vakuuttaa, että radiolaitetyyppi ARS 4-B on direktiivin 2014/53/EU mukainen. EU-vaatimustenmukaisuusvakuutuksen täysimittainen teksti on saatavilla seuraavassa internetosoitteessa: http://continental.automotive-approvals.com/
	Radiotaajuudet, joilla radiolaitte toimii: 76-77 GHz
	Suurin mahdollinen lähetytsto radiotaajuuksilla, joilla radiolaitte toimii: 3.16W (35dBm RMS EIRP)

24_RED_SV_Swedish

FÖRENKLAD EU-FÖRSÄKRAN OM ÖVERENSSTÄMMELSE	Härmed försäkrar ADC Automotive Distance Control Systems GmbH att denna typ av radioustrüstning ARS 4-B överensstämmer med direktiv 2014/53/EU. Den fullständiga texten till EU-försäkran om överensstämmelse finns på följande webbadress: http://continental.automotive-approvals.com/
	Det eller de frekvensband där radioustrüstningen arbetar: 76-77 GHz
	Den maximala radiofrekvenseffekt som överförs inom det eller de frekvensband där radioustrüstningen arbetar: 3.16W (35dBm RMS EIRP)

Declaration of Conformity

01_RED_IS_Icelandic

EINFÖLDUÐ ESB SAMRÆMISYFIRLÝSING	Hér með lýsir ADC Automotive Distance Control Systems GmbH því yfir, að fjarskiptabúnaðurinn að gerð ARS 4-B er í samræmi við tilskipun 2014/53/ ESB. Textinn í fullri lengd um Samræmisyfirlýsingu ESB er aðgengilegur á eftirfarandi veffangi: http://continental.automotive-approvals.com/
	Bandbreidd(ir), sem fjarskiptabúnaðurinn starfar í: 76–77 GHz
	Hámarks fjarskiptatöni sendistyrkleika í bandbreiddinni/bandbreiddunum sem fjarskiptabúnaðurinn starfar í: 3.16W (35dBm RMS EIRP)

01_RED_TR_Turkish

BASITLEŞTİRİLMİŞ AB UYGUNLUK BEYANI	İşbu belge ile, ADC Automotive Distance Control Systems GmbH şirketi ARS 4-B tipi radyo ekipmanının 2014/53/AB sayılı direktife uygun olduğunu beyan eder. AB uygunluk beyanının tam metni aşağıdaki internet adresinde mevcuttur: http://continental.automotive-approvals.com/
	Radyo cihazının çalıştığı frekans bandı/bantları: 76–77 GHz
	Radyo ekipmanının çalıştığı frekans bandında/bantlarında iletilen maksimum radyo frekansı gücü: 3.16W (35dBm RMS EIRP)

RUSSIA,KAZAKHSTAN,BELARUS



Serbia



Morocco

AGREE PAR L'ANRT MAROC
Numéro d'agrément : MR 9778 ANRT 2014
Date d'agrément : 2014-11-11

Bahrain

The Equipment Identified hereon is approved for use under the following rules

- 1- This equipment must not cause harmful interference to other services.
- 2- This equipment is subject to harmful interference, and the owner of this equipment must not claim for protection.

NIGERIA

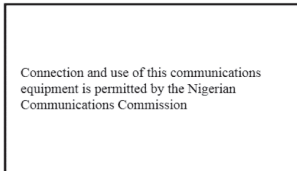

INDONESIA

68161/R/SDPPI/2021



8032

UKRAINE



справжнім (найменування виробника ADC Automotive Distance Control Systems GmbH) заявляє, що тип радіообладнання (позначення типу радіообладнання ARS4-B) відповідає Технічному регламенту радіообладнання; повний текст декларації про відповідність доступний на веб-сайті за такою адресою: <http://continental.automotive-approvals.com/>

3* sDoC_RED_Ukrainian

найменування та адресу виробника	ADC Автомобілі Дістанс Контрол Системс ГмбХ Пітер-Дорнієр-Штрассе 10, 88131, Ліндау, Німеччина (ADC Automotive Distance Control Systems GmbH Peter-Dornier-Strasse 10, 88131, Lindau, Germany)
СПРОЩЕНА ДЕКЛАРАЦІЯ ЄС ПРО ВІДПОВІДНІСТЬ	Цим ADC Automotive Distance Control Systems GmbH заявляє, що радіообладнання типу ARS4-B відповідає вимогам Директиви 2014/53/EU. Повний текст декларації ЄС про відповідність доступний за наступною адресою в мережі Інтернет: http://continental.automotive-approvals.com/
	Частотний діапазон(-и), в якому працює радіообладнання: 76-77 ГГц
	Максимальна потужність радіочастотного сигналу, що передається у частотному діапазоні(-ях), в якому працює радіообладнання: 3.16 Вт (35 дБм середньоквадратична ефективна потужність випромінювання)

ARS4-B has been registered with: UA RF: 1CONT 0001

JORDAN

"Name of the manufacturer

ADC Automotive Distance Control Systems GmbH

Address of the manufacturer: Peter-Dornier-Strasse 10, 88131 Lindau, Germany

Brand,Model

Continental, ARS4-B , "

Specifications/Customer Information
Declaration of Conformity

Singapore

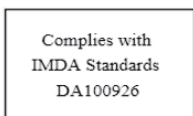

South Africa



Taiwan

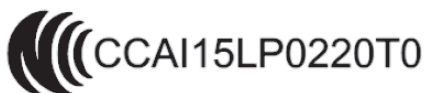

「取得審驗證明之低功率射頻器材，非經核准，公司、商號或使用者均不得擅自變更頻率、加大功率或變更原設計之特性及功能。低功率射頻器材之使用不得影響飛航安全及干擾合法通信；經發現有干擾現象時，應立即停用，並改善至無干擾時方得繼續使用。前述合法通信，指依電信管理法規定作業之無線電通信。低功率射頻器材須忍受合法通信或工業、科學及醫療用電波輻射性電機設備之干擾。」

Botswana



OMAN

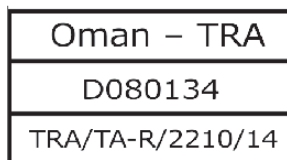

DOMINICAN REPUBLIC / EL SALVADOR / PALAU

Model: ARS4-B

IC: 4135A-ARS4B

FCC ID: OAYARS4B

This device complies with Part 15 of the FCC Rules and with Industry Canada licence-exempt RSS standard(s). Operation is subject to the following two conditions:

- (1) This device may not cause harmful interference, and
- (2) This device must accept any interference received, including interference that may cause undesired operation.

Le présent appareil est conforme aux CNR d'Industrie Canada applicables aux appareils radio exempts de licence. L'exploitation est autorisée aux deux conditions suivantes:

- (1) l'appareil ne doit pas produire de brouillage, et
- (2) l'utilisateur de l'appareil doit accepter tout brouillage radioélectrique subi, même si le brouillage est susceptible d'en compromettre le fonctionnement.

Radiofrequency radiation exposure information:

This equipment complies with FCC and IC radiation exposure limits set forth for an uncontrolled environment. This equipment should be installed and operated with minimum distance of 30 cm between the radiator and your body.

This transmitter must not be co located or operating in conjunction with any other antenna or transmitter.

Cet équipement est conforme aux limites d'exposition aux rayonnements IC établies pour un environnement non contrôlé. Cet équipement doit être installé et utilisé avec un minimum de 30 cm de distance entre la source de rayonnement et votre corps.

FCC Notice

Changes or modifications not expressly approved by the party responsible for compliance could void the user's authority to operate the equipment.

THAILAND

“ เครื่องโทรคมนาคมและอุปกรณ์นี้ มีความสอดคล้องตามมาตรฐานหรือข้อกำหนดของ กสทช. ”

“ เครื่องโทรคมนาคมที่มีระดับการแผ่คลื่นแม่เหล็กไฟฟ้าสอดคล้องตามมาตรฐานความปลอดภัยต่อสุขภาพของมนุษย์จากการใช้
เครื่องโทรคมนาคมที่คณะกรรมการโทรคมนาคมแห่งชาติประกาศกำหนด ”

Specifications/Customer Information
Declaration of Conformity

Malaysia



MOLDOVA

Manufacturer Postal Address

	ADC Automotive Distance Control Systems GmbH Peter-Dornier-Strasse 10, 88131 Lindau, Germany
--	---

01_MD_Romanian

DECLARAȚIA UE DE CONFORMITATE SIMPLIFICATĂ	Prin prezenta, ADC Automotive Distance Control Systems GmbH declară că tipul de echipamente radio ARS4-B este în conformitate cu Reglementarea tehnică „Punerea la dispoziție pe piață a echipamentelor radio”. Textul integral al declarației de conformitate este disponibil la următoarea adresă de Internet: http://continental-automotive-approvals.com/ .
	Banda (benzile) de frecvențe în care funcționează echipamentul radio: 76–77 GHz

	Puterea maximă de radiofrecvență transmisă în banda (benzile) de frecvențe în care funcționează echipamentul radio: 3.16W (35dBm RMS EIRP)
--	---

VIETNAM



UK

A) Generic information:

Manufacturer Postal Address

ADC Automotive Distance Control Systems GmbH
Peter-Dornier-Straße 10, 89131 Lindau, Germany

01_UK_English

**SIMPLIFIED UK
DECLARATION OF
CONFORMITY**

Hereby, ADC Automotive Distance Control Systems GmbH declares that the radio equipment type AR64-B is in compliance with Radio Equipment Regulations of the United Kingdom. The full text of the UK declaration of conformity is available at the following internet address:
<http://conformity.adc-automotive-approvals.com/>

Frequency band(s) in which the radio equipment operates:
70-77 GHz

Maximum radio-frequency power transmitted in the frequency band(s) in which the radio equipment operates:
3.16W (25dBm RMS EIRP)



Importer Information

Name: Mazda Motors UK Limited

Address: Victory Way, Crossways Business Park, Dartford, Kent, DA2 6DT, UK

Paraguay



CONATEL

NR: 2019-07-I-0353

Garden MPY S.A.

Republica Argentina y Facundo Machain, Asuncion, PARAGUAY

Declaration of Conformity

ISRAEL

חל איסור לבצע פעולות במכשיר שיש בהן כדי לשנות את תכונותיו האלחוטיות של המכשיר, ובכלל זה שינויי תוכנה, החלפת אנטנה מקורית או הוספת אפשרות לחיבור לאנטנה חיצונית, בלא קבלת אישור משרד התקשורת, בשל החשש להפרעות אלחוטיות.

SENEGAL

AGREE PAR ARTP SENEGAL
Numéro d'agrément : N° 072193 / AG / ER



Front Side Radar/Rear Side Radar System

We, FURUKAWA AUTOMOTIVE SYSTEMS INC., hereby declare, at our sole responsibility, that the following product conforms to the Essential Requirements of Radio Equipment Directive 2014/53/EU. The latest Declaration of Conformity is available at the following address:

address: <http://www.furukawaas.co.jp/english/approval/>

English	Frequency range : 24.05 GHz to 24.25 GHz Maximum radiated peak power(e.i.r.p) : -10 dBm Temperature range : -40°C to +85°C
Bulgarian	Честотен диапазон: 24,05 GHz до 24,25 GHz Максимално излъчвана върхова мощност (е.им): -10 dBm Температурен диапазон: -40°C до +85°C
Czech	Frekvenční rozsah: 24,05 GHz až 24,25 GHz Maximum vyzářeného výkonu (e.i.r.p): -10 dBm Teplotní rozsah: -40°C až +85°C
Danish	Frekvensinterval: 24,05 GHz til 24,25 GHz Maksimalt udstrålede spidseffekt (e.i.r.p): -10 dBm Temperaturinterval: -40°C til +85°C
German	Frequenzbereich: 24,05 GHz bis 24,25 GHz Max. Strahlung sleistungspiegel (EIRP): -10 dBm Temperaturbereich: -40°C bis +85°C
Estonian	Sagedusala: 24,05 GHz kuni 24,25 GHz Maksimaalne kiirguse tipvõimsus (ekvivalentne isotroopne kiirgusvõimsus): -10 dBm Temperatuurivahemik: -40 °C kuni +85 °C
Gaeilge	Raon minicíochta: idir 24.05 GHz agus 24.25 GHz Buaic-chumhacht radaithe uasta (e.i.r.p): -10 dBm Raon teochta: -40°C to +85°C
Greek	Περιοχή συχνοτήτων: 24,05 GHz έως 24,25 GHz Μέγιστη ακτινοβολούμενη ισχύς αιχμής (EIRP): -10 dBm Έυρος θερμοκρασίας: -40°C έως +85°C
Spanish	Rango de Frecuencia: 24,05 GHz a 24,25 GHz Potencia Isótropa Radiada Equivalente (e.i.r.p, por sus siglas en inglés): -10 dBm Rango de temperatura: -40°C a +85°C
French	Bande de fréquence: 24,05 GHz to 24,25 GHz Puissance maximale de crête rayonnée (e.i.r.p): -10 dBm Écart de température: -40°C à +85°C
hrvatski	Frekvencijski raspon: 24,05 GHz do 24,25 GHz Maksimalna emitirana vršna snaga (e.i.r.p): -10 dBm Raspon temperatura: -40°C do +85°C
Italian	Gamma di frequenza : da 24,05 GHz ta 24,25 GHz Picco massimo delle potenza irradiata (e.i.r.p): -10 dBm Escursione termica: da -40°C a +85°C
Latvian	Frekvences diapazons: 24,05 GHz līdz 24,25 GHz Maksimālā izstarotā maksimālā jauda (e.i.r.p): -10 dBm Temperatūras diapazons: -40°C līdz +85°C
Lithuania	Dažnio intervalas: 24,05–24,25 GHz Didžiausioji spinduliuotės galia (EIRP): -10 dBm Temperatūros intervalas: -40 – +85 °C
Lëtzebuergesch	Frequenzberäich: 24.05 GHz bis 24.25 GHz Maximal ausgestraalt Spëtztzeleeschung (e.i.r.p): -10 dBm Temperaturberäich: -40°C bis +85°C
Hungarian	Frekvenciatartomány: 24,05 GHz - 24,25 GHz Maximum sugárzott csúcsteljesítmény (e.i.r.p): -10 dBm Hőmérsékleti tartomány: -40 °C - +85 °C

Declaration of Conformity

Maltese	Medda tal-frekwenza: 24.05 GHz sa 24.25 Ghz L-ogħla qawwa rradjata massima (e.i.r.p): -10 dBm Firxa tat-Temperaturatura: -40°C sa +85°C
Dutch	Frequentiebereik: 24,05 GHz tot 24,25 GHz Maximaal uitgezonden vermogen (EIRP): -10 dBm Temperatuurbereik: -40°C tot +85°C
German	Frequenzbereich: 24,05 GHz bis 24,25 GHz Max. Strahlung sleistungspegel (EIRP): -10 dBm Temperaturbereich: -40°C bis +85°C
Polish	Zakres częstotliwości: od 24,05 GHz do 24,25 GHz Maksymalna wypromieniowana moc (EIRP): -10 dBm Zakres temperatur: od -40°C do +85°C
Portuguese	Alcance de frequência: 24,05 GHz a 24,25 GHz Máximo Potência de pico irradiada (e.i.r.p): -10 dBm Faixa de temperatura: -40°C a +85°C
Rumanian	Interval de frecvență: 24,05 GHz - 24,25 GHz Putere de vârf maximă radiată (e.i.r.p): -10 dBm Interval de temperatură: -40 °C - +85 °C
Slovenian	Frekvenčni razpon: 24,05 GHz do 24,25 GHz Maksimalna zračena moč (e.i.r.p): -10 dBm Temperaturni razpon: -40°C to +85°C
Slovakian	Frekvenčný rozsah: 24,05 GHz až 24,25 GHz Maximum efektívneho izotropného vyžiarého výkonu (e.i.r.p): -10 dBm Teplotný rozsah: -40°C zž +85°C
Finnish	Taajuusalue: 24,05 – 24,25 GHz Maksimi säteilyhuipputeho (e.i.r.p): -10 dBm Lämpötila-alue: -40°C - +85°C
Swedish	Frekvensintervall: 24,05 GHz till 24,25 GHz Högsta utstrålade maximal effekt (e.i.r.p): -10 dBm Temperaturintervall: -40°C till +85°C
Serbia	 ИО38 21
United Kingdom	 FURUKAWA AUTOMOTIVE SYSTEMS INC., hereby declare, at our sole responsibility, that 24GMMR20 conforms to the essential requirements of the radio equipment regulations of the United Kingdom. The UK Declaration of Conformity is available at the following address : http://www.furukawaas.co.jp/english/approval/
Ukraine	 MODEL:24GMMR20 FURUKAWA ELECTRIC CO.,Ltd. Адреса виробника : FURUKAWA AUTOMOTIVE SYSTEMS INC. 1000, Amago, Koura-cho, Inukami-gun, Shiga, JAPAN справжнім(FURUKAWA AUTOMOTIVE SYSTEMS INC.) заявляє, що тип радіобладнання (Радіолокатор периферійного безперервного нагляду діапазоном 24 ГГц) відповідає Технічному регламенту радіобладнання; повний текст декларації про відповідність доступний на веб-сайті за такою адресою http://www.furukawaas.co.jp/english/approval/ Діапазон частот: від 24,05 до 24,25 ГГц Максимальна пікова потужність випромінювання (еквівалентна ізотропній потужності): -10дБм Діапазон температур: від -40 °C до + 85 °C

Ghana	NCA Approved: 7E5-7M-109-RDR		
Nigeria	Connection and use of this communications equipment is permitted by the Nigerian Communications Commission		
Paraguay		Marca: FURUKAWA Modelo: 24GMMR20 Fabricante: Furukawa Automotive Systems INC. Número del Registro: 2021-07-I-0394	
Taiwan	 警語 取得實驗證明之低功率射頻器材，非經核准，公司，商號或使用者均不得擅自變更頻率，加大功率或變更原設計之特性及功能。低功率射頻器材之使用不得影響飛航安全及干擾合法通信；經發現有干擾現象時，應立即停用，並改善至無干擾時方得繼續使用。前述合法通信，指依電信管理法規作業之無線電通信。低功率射頻器材須忍受合法通信或工業、科學及醫療用電波輻射性電機設備之干擾。		
Vietnam	 		
INDONESIA	77980/SDPPI/2021 PLG ID:8032   <p style="font-size: small; text-align: right;">Dilarang melakukan perubahan spesifikasi yang dapat menimbulkan gangguan bagi peralatan komunikasi lainnya yang sejenis.</p>		
Malaysia	 HIDF18000266	South Africa	 TA-2021/1522 APPROVED
Oman	OMAN-TRA R/11893/21 D172338	Singapore	 Complies with IMDA Standards DA100926
Israel	מספר אישור התאמה מטעם משרד התקשורת-5183926 חל אישור לבצע פעולות במכשיר שיש בהן כדי לשנות את תכונותיו האלחוטיות של המכשיר, ובכלל זה שינוי תוכנה, החלפת אנטנה מקורית או הספת אפסות לחיבור לאנטנה חיצונית, בלא קבלת אישור משרד התקשורת, בשל החשש להפרעות אלחוטיות. חל אישור על הפעלת המכשיר מחוץ למבנה, בשל חשש להפרעות אלחוטיות.		

Declaration of Conformity

Audio System

[*] : CL-MM6CE0JT, CL-MM6CE1JT, CL-MM6CA0JT

Cyprus, Canary Islands, Austria, Greece, Italy, Switzerland, Belgium, Denmark, Finland, Norway, Portugal, Spain, Sweden, Hungary, Germany, Poland, Bulgaria, Croatia, Slovenia, Luxembourg, Slovakia, Latvia, Lithuania, France, Czech, Estonia, Iceland, Romania, Netherlands, Malta, Ireland, Liechtenstein, Albania, French Guiana, Guadeloupe, Virgin Islands, St. Martin, Martinique, Faeroe Islands, Reunion

Manufacturer

•Name : Panasonic Automotive Systems Co., Ltd.
•Address : 4261 Ikonobe-cho, Tsuzuki-ku, Yokohama-shi, Kanagawa-ken, 224-8520, Japan

Importer, Address :

Mazda Motor Logistics Europe NV
Blaasveldstraat 162, 2830 Willebroek, België
Mazda Motor Poland sp.zo.o.
ul. Postępu 14B, 02-676 Warsaw, Poland
Mazda Motor Czech, s.r.o.
Türkova 2319/5b, Chodov, 149 00 Prague 4, Czech Republic
Mazda Motor Slovakia, s.r.o.
LINDNER II, Galvaniho 7/B, Bratislava - Ružinov 821 04, Slovak Republic
Mazda Motor Logistics Europe NV Merkezi Belçika Türkiye İstanbul Şubesi
Merdivenköy Mah. Dikyoł Sok. Business İstanbul B Blok No:2/72, 34732 Kadıköy- İstanbul, Turkey

Model No.[*]

<CL-MM6CE0JT, CL-MM6CE1JT, CL-MM6CA0JT>

Specifications of Bluetooth

Frequency band : 2402-2480MHz

Maximum radio-frequency power : 100mW Max

<CL-MM6CE0JT, CL-MM6CE1JT, CL-MM6CA0JT>

Specifications of WLAN

Frequency band : 2412-2472MHz

Maximum radio-frequency power : 100mW Max

<CL-MM6CE0JT>

Specifications of WLAN

Frequency band : 5725-5875MHz

Maximum radio-frequency power : 25mW Max

Hereby, Panasonic Automotive Systems Co., Ltd. declares that the radio equipment type [*] is in compliance with Directive 2014/53/EU.

The full text of the EU declaration of conformity is available at the following internet address:

<https://www.ptc.panasonic.eu/>

Me anë të kësaj, Panasonic Automotive Systems Co., Ltd. deklaron se pajisjet e radios [*] janë në përputhje me Direktivën 2014/53 / BE.

Teksti i plotë i deklaratës së BE-së për konformitetin është në dispozicion në adresën e mëposhtme të internetit:

<https://www.ptc.panasonic.eu/>

С настоящото Panasonic Automotive Systems Co., Ltd. декларира, че този тип радиосъоръжение [*] е в съответствие с Директива 2014/53/ЕС.
Цялостният текст на ЕС декларацията за съответствие може да се намери на следния интернет адрес:
<https://www.ptc.panasonic.eu/>

Tímto Panasonic Automotive Systems Co., Ltd. prohlašuje, že typ rádiového zařízení [*] je v souladu se směrnicí 2014/53/EU.
Úplné znění EU prohlášení o shodě je k dispozici na této internetové adrese:
<https://www.ptc.panasonic.eu/>

Hermed erklærer Panasonic Automotive Systems Co., Ltd. , at radioudstyrstypen [*] er i overensstemmelse med direktiv 2014/53/EU.
EU-overensstemmelseserklæringens fulde tekst kan findes på følgende internetadresse:
<https://www.ptc.panasonic.eu/>

Hiermit erklárt Panasonic Automotive Systems Co., Ltd. , dass der Funkanlagentyp [*] der Richtlinie 2014/53/EU entspricht.
Der vollständige Text der EU-Konformitätserklärung ist unter der folgenden Internetadresse verfügbar:
<https://www.ptc.panasonic.eu/>

Με την παρούσα ο/η Panasonic Automotive Systems Co., Ltd. , δηλώνει ότι ο ραδιοεξοπλισμός [*] πληροί την οδηγία 2014/53/ΕΕ.
Το πλήρες κείμενο της δήλωσης συμμόρφωσης ΕΕ διατίθεται στην ακόλουθη ιστοσελίδα στο διαδίκτυο:
<https://www.ptc.panasonic.eu/>

Por la presente, Panasonic Automotive Systems Co., Ltd. declara que el tipo de equipo radioeléctrico [*] es conforme con la Directiva 2014/53/UE.
El texto completo de la declaración UE de conformidad está disponible en la dirección Internet siguiente:
<https://www.ptc.panasonic.eu/>

Käesolevaga deklareerib Panasonic Automotive Systems Co., Ltd. , et käesolev raadioseadme tüüp [*] vastab direktiivi 2014/53/EL nõuetele.
Eli vastavusdeklaratsiooni täielik tekst on kättesaadav järgmisel internetiaadressil:
<https://www.ptc.panasonic.eu/>

Panasonic Automotive Systems Co., Ltd. vakuuttaa, että radiolaitetyypit [*] on direktiivin 2014/53/EU mukainen.
EU-vaatimustenmukaisuusvakuutuksen täysimittainen teksti on saatavilla seuraavassa internetosoitteessa:
<https://www.ptc.panasonic.eu/>

Le soussigné, Panasonic Automotive Systems Co., Ltd. , déclare que l'équipement radioélectrique du type [*] est conforme à la directive 2014/53/UE.
Le texte complet de la déclaration UE de conformité est disponible à l'adresse internet suivante:
<https://www.ptc.panasonic.eu/>

Declaration of Conformity

Panasonic Automotive Systems Co., Ltd. ovime izjavljuje da je radijska oprema tipa [*] u skladu s Direktivom 2014/53/EU.

Cjeloviti tekst EU izjave o sukladnosti dostupan je na sljedećoj internetskoj adresi:

<https://www.ptc.panasonic.eu/>

Panasonic Automotive Systems Co., Ltd. igazolja, hogy a [*] típusú rádióberendezés megfelel a 2014/53/EU irá nyelvnek.

Az EU-megfelelőségi nyilatkozat teljes szövege elérhető a következő internetes címen:

<https://www.ptc.panasonic.eu/>

Hér með lýsir Panasonic Automotive Systems Co., Ltd. því yfir að gerð útvarpsbúnaðarins [*] sé í samræmi við tilskipun 2014/53 / ESB.

Heildartexti samræmisýfirlýsingar ESB er að finna á eftirfarandi internetið:

<https://www.ptc.panasonic.eu/>

Il fabbricante, Panasonic Automotive Systems Co., Ltd. , dichiara che il tipo di apparecchiatura radio [*] è conforme alla direttiva 2014/53/UE.

Il testo completo della dichiarazione di conformità UE è disponibile al seguente indirizzo Internet:

<https://www.ptc.panasonic.eu/>

Aš, Panasonic Automotive Systems Co., Ltd. , patvirtinu, kad radijo įrenginių tipas [*] atitinka Direktivą 2014/53/ES.

Visas ES atitikties deklaracijos tekstas prieinamas šiuo interneto adresu:

<https://www.ptc.panasonic.eu/>

Ar šo Panasonic Automotive Systems Co., Ltd. deklarė, ka radioiekārta [*] atbilst Direktīvai 2014/53/ES.

Pilns ES atbilstības deklarācijas teksts ir pieejams šādā interneta vietnē:

<https://www.ptc.panasonic.eu/>

B'dan, Panasonic Automotive Systems Co., Ltd. , niddikjara li dan it-tip ta' taghmir tar-radju [*] huwa konformi mad-Direttiva 2014/53/UE.

It-test kollu tad-dikjarazzjoni ta' konformità tal-UE huwa disponibbli f'dan l-indirizz tal-Internet li ġej:

<https://www.ptc.panasonic.eu/>

Herved erklærer Panasonic Automotive Systems Co., Ltd. at radioutstyrtypen [*] er i samsvar med direktiv 2014/53 / EU.

Hele teksten til EU-samsvarserklæringen er tilgjengelig på følgende internetadresse:

<https://www.ptc.panasonic.eu/>

Hierbij verklaar ik, Panasonic Automotive Systems Co., Ltd. , dat het type radioapparatuur [*] conform is met Richtlijn 2014/53/EU.

De volledige tekst van de EU-conformiteitsverklaring kan worden geraadpleegd op het volgende internetadres:

<https://www.ptc.panasonic.eu/>

Panasonic Automotive Systems Co., Ltd. niniejszym oświadcza, że typ urządzenia radiowego [*] jest zgodny z dyrektywą 2014/53/UE.
Pełny tekst deklaracji zgodności UE jest dostępny pod następującym adresem internetowym:
<https://www.ptc.panasonic.eu/>

O(a) abaixo assinado(a) Panasonic Automotive Systems Co., Ltd. declara que o presente tipo de equipamento de rádio [*] está em conformidade com a Diretiva 2014/53/UE.
O texto integral da declaração de conformidade está disponível no seguinte endereço de Internet:
<https://www.ptc.panasonic.eu/>

Prin prezenta, Panasonic Automotive Systems Co., Ltd. declară că tipul de echipamente radio [*] este în conformitate cu Directiva 2014/53/UE.
Textul integral al declarației UE de conformitate este disponibil la următoarea adresă internet:
<https://www.ptc.panasonic.eu/>

Ovim, Panasonic Automotive Systems Co., Ltd., deklariše da je [*] u skladu sa osnovnim zahtevima i ostalim relevantnim odredbama Direktive 2014/53/EU
Pun tekst EU deklaracije o usaglašenosti dostupan je na sledećoj internet adresi:
<https://www.ptc.panasonic.eu/>

Panasonic Automotive Systems Co., Ltd. týmto vyhlasuje, že rádiové zariadenie typu [*] je v súlade so smernicou 2014/53/EÚ.
Úplné EÚ vyhlásenie o zhode je k dispozícii na tejto internetovej adrese:
<https://www.ptc.panasonic.eu/>

Panasonic Automotive Systems Co., Ltd. potrjuje, da je tip radijske opreme [*] skladen z Direktivo 2014/53/EU.
Celotno besedilo izjave EU o skladnosti je na voljo na naslednjem spletnem naslovu:
<https://www.ptc.panasonic.eu/>

Härmed försäkrar Panasonic Automotive Systems Co., Ltd. att denna typ av radioutrustning [*] överensstämmer med direktiv 2014/53/EU.
Den fullständiga texten till EU-försäkran om överensstämmelse finns på följande webbadress:
<https://www.ptc.panasonic.eu/>

Panasonic Automotive Systems Co., Ltd. , [*] türü telsiz ekipmanının 2014/53/EU Direktifine uygun olduğunu beyan etmektedir.
AB uygunluk beyanının tam metnine aşağıdaki internet adresinden ulaşılabilir:
<https://www.ptc.panasonic.eu/>

Declaration of Conformity

[*] : CL-MM6CE0JT

UK

Manufacturer

•Name : Panasonic Automotive Systems Co., Ltd.

•Address : 4261 Ikonobe-cho, Tsuzuki-ku, Yokohama-shi, Kanagawa-ken, 224-8520, Japan

Importer, Address :

Mazda Motors UK Limited

Crossways Business Park, Victory Way, Dartford DA2 6DT, Kent, UK

Model No.[*]

<CL-MM6CE0JT>

Specifications of Bluetooth

Frequency band : 2402-2480MHz

Maximum radio-frequency power : 100mW Max

<CL-MM6CE0JT>

Specifications of WLAN

Frequency band : 2412-2472MHz

Maximum radio-frequency power : 100mW Max

<CL-MM6CE0JT>

Specifications of WLAN

Frequency band : 5725-5875MHz

Maximum radio-frequency power : 25mW Max

Hereby, Panasonic Automotive Systems Co., Ltd. declares that the radio equipment type[*] is in compliance with The Radio Equipment Regulations 2017.

The full text of the UK declaration of conformity is available at the following internet address:

<https://www.ptc.panasonic.eu/>



Moldova

Producător

Numele : Panasonic Automotive Systems Co., Ltd.

Adresa : 4261 Ikonobe-cho, Tsuzuki-ku, Yokohama-shi, Kanagawa-ken, 224-8520, Japonia

Importatorii Numele :

Denumirea comercială înregistrată : Mazda Austria Gesellschaft m. b. H.

Adresa poștală : Ernst Diez Strasse 3, 9020 Klagenfurt, Österreich

Numarul modelului.[*]

<CL-MM6CE0JT>

Bluetooth

Banda de frecvență : 2402-2480MHz

Puterea maximă a frecvenței radio : 100mW Max

<CL-MM6CE0JT>

WLAN

Banda de frecvență : 2412-2472MHz

Puterea maximă a frecvenței radio : 100mW Max

<CL-MM6CE0JT>

WLAN

Banda de frecvență : 5725-5875MHz

Puterea maximă a frecvenței radio : 25mW Max

Prin prezenta, Panasonic Automotive Systems Co., Ltd. declară că tipul de echipamente radio [*] este în conformitate cu Reglementarea tehnică „Punerea la dispoziție pe piață a echipamentelor radio”.

Textul integral al declarației de conformitate este disponibil la următoarea adresă de Internet:

<https://service.panasonic.ua>

Declaration of Conformity

[*] : CL-MM6CE1JT

Ukraine

Виробники

назву компанії; Panasonic Automotive Systems Co., Ltd.
адресу ; 4261 Ikonobe-cho, Tsuzuki-ku, Yokohama-shi, Kanagawa-ken, 224-8520, Japan

Імпортери

назву компанії; SC AUTO International
адресу ; 22А, Stepana Bandery ave, Kiev, 04655, Ukraine

моделі;[*]

Bluetooth

смугу радіочастот, в якій працює радіообладнання; 2402-2480MHz
максимальну потужність випромінювання в смузі радіочастот, в якій працює радіообладнання; 100mW

WLAN

смугу радіочастот, в якій працює радіообладнання; 2412-2472MHz
максимальну потужність випромінювання в смузі радіочастот, в якій працює радіообладнання; 100mW

справжнім Panasonic Automotive Systems Co., Ltd. заявляє, що тип радіообладнання [*] відповідає Технічному регламенту радіообладнання;
повний текст декларації про відповідність доступний на веб-сайті за такою адресою:
<https://service.panasonic.ua/>
(розділ «Технічне регулювання»)

Mongolia



ID: A19000702



ID: A21000516

Kazakhstan, Armenia, Russia, Belarus



Russia

Local representative

"Uniservis" Ltd.

1st Vladimirovskaya street, building 20A, 1st floor, premises 1, room 17, Moscow 111123, Russia. OGRN 5107746076873.

ООО «Юнисервис»

Россия, 111123, г. Москва, ул. 1-ая Владимирова, д. 20А, этаж 1 пом. 1, комн. 17, ОГРН 5107746076873.

Declaration of Conformity

This telecommunication equipment conforms to the standard or technical requirements of NBTC.

取得審驗證明之低功率射頻器材，非經核准，公司、商號或使用者均不得擅自變更頻率、加大功率或變更原設計之特性及功能。
 低功率射頻器材之使用不得影響飛航安全及干擾合法通信；經發現有干擾現象時，應立即停用，並改善至無干擾時方得繼續使用。
 前述合法通信，指依電信管理法規定作業之無線電通信。
 低功率射頻器材須忍受合法通信或工業、科學及醫療用電波輻射性電機設備之干擾。

TRA
REGISTERED No:
ER04654/22
DEALER No:
DA0052708/10

מספר אישור התאמה מטעם משרד התקשורת: 55-10553
 חל איסור לבצע פעולות במכשיר אשר יש בהן כדי לשנות את תכונותיו האלחוטיות של המכשיר,
 ובכלל זה החלפת אנטנה מקורית או הוספת אפשרות לחיבור לאנטנה חיצונית ללא קבלת אישור
 משרד התקשורת, בשל החשש להפרעות אלחוטיות

Complies with
IMDA Standards
DA100926

NCA APPROVED:7E5-BH-1CB-RDR

Connection and use of this communications
equipment is permitted by the Nigerian
Communications Commission

BOCRA
REGISTERED No:
BOCRA/TA/2021/6533

TRC/LPD/2018/305



PARAGUAY

Garden MPY S.A.
Republica Argentina y Facundo Machain, Asuncion,
PARAGUAY

This device complies with part 15 of the FCC Rules. Operation is subject to the following two conditions:

- (1) This device may not cause harmful interference, and
- (2) this device must accept any interference received, including interference that may cause undesired operation.

NOTE :

Properly shielded and grounded cables and connectors must be used for connection to host computers and / or peripherals in order to meet FCC emission limits.

WARNING :

RF Exposure

This equipment complies with FCC radiation exposure limits set forth for an uncontrolled environment and meets the FCC radio frequency (RF) Exposure Guidelines. This equipment has very low levels of RF energy that it deemed to comply without maximum permissive exposure evaluation (MPE). [But it is desirable that it should be installed and operated keeping the radiator at least 20cm or more away from person's body.]

This transmitter must not be co-located or operated in conjunction with any other antenna or transmitter.

FCC CAUTION :

Changes or modifications not expressly approved by the party responsible for compliance could void the user's authority to operate the equipment.

Declaration of Conformity

Radio System



Model No.: CQ-TM6CE04M / CQ-TM6CE14M

Bland : Panasonic

Country of origin : Malaysia

No.355.2017(Ukraine)

Виробники:

назву компанії: Panasonic Automotive Systems Co., Ltd.

адресу: 4261 Ikonobe-cho, Tsuzuki-ku, Yokohama-shi, Kanagawa-ken, 224-8520, Japan

Імпортер:

назву компанії: Auto International

адресу: 04073, 22-а Степана Бандери Ave., Kiev, Ukraine

справжнім Panasonic Corporation заявляє, що тип радіообладнання [*]
відповідає Технічному регламенту радіообладнання;
повний текст декларації про відповідність доступний на веб-сайті за такою
адресою:
<https://service.panasonic.ua/>
(розділ «Технічне регулювання»)
[*] CQ-TM6CE04M / CQ-TM6CE14M

With DAB radio

Manufacture, Address:

Üretici, Adres:

Prodhimi, Adresa:

Panasonic Corporation.

4261 Ikonobe-cho, Tsuzuki-ku, Yokohama-City Kanagawa-ken 224-8520, Japan

Importer, Address:

İthalatçı, Adres:

Importuesi, Adresa:

Mazda Motor Logistics Europe NV

Blaasveldstraat 162, 2830 Willebroek, België

Mazda Motor Poland sp.z.o.o.

ul. Postępu 14B, 02-676 Warsaw, Poland

Mazda Motor Czech, s.r.o.

Tůrkova 2319/5b, Chodov, 149 00 Prague 4, Czech Republic

Mazda Motor Slovakia, s.r.o.

LINDNER II, Galvaniho 7/B, Bratislava - Ružinov 821 04, Slovak Republic

Model. No.: CQ-TM6CE04M

[English]	Hereby, Panasonic Corporation declares that the radio equipment type [CQ-TM6CE04M] is in compliance with The Radio Equipment Regulations 2017. The full text of the UK declaration of conformity is available at the following internet address: https://www.ptc.panasonic.eu/
-----------	---

**UK
CA**

Specifications/Customer Information

Declaration of Conformity

Albania	<p>Me anë të kësaj dokumenti, "Panasonic Corporation" deklaron se radioapajisja e tipit të listuar më lart është në përputhshmëri me Direktivën 2014/53/EU.</p> <p>Hyni në http://www.ptc.panasonic.eu/, klikoni "Declaration of Conformity (Deklarata e përputhshmërisë)", shkruani termin kyç në kutinë e kërkimit të termave kyçe dhe mund të shkarkoni versionin e fundit të "DECLARATION OF CONFORMITY (DEKLARATËN E PËRPUTHSHMËRISË)" (DoC).</p> <p>Termi kyç: CQ-TMBC04M</p>
Bulgarian	<p>С настоящото Panasonic Corporation декларира че радиооборудването от типа посочен по-горе е в съответствие с Директива 2014/53/ЕС.</p> <p>Отидете на http://www.ptc.panasonic.eu/, щракнете върху „Declaration of Conformity (Декларация за съответствие)“, въведете ключовата дума, дадена по-долу в полето за търсене по ключова дума и ще можете да изтеглите най-новата „DECLARATION OF CONFORMITY (ДЕКЛАРАЦИЯ ЗА СЪОТВЕ ТВИЕ)“ (DoC).</p> <p>Ключова дума: CQ-TMBC04M</p>
Czech	<p>Tímto společnost Panasonic Corporation prohlašuje, že výše uvedeně radiové zařízení typu CQ-TMBC04M je v souladu se směrnicí 2014/53/EU.</p> <p>Když přejdete na stránku http://www.ptc.panasonic.eu/, klikněte na „Declaration of Conformity (Prohlášení o shodě)“ a zadáte číslo modelu CQ-TMBC04M do pole pro vyhledávání podle klíčového slova, budete si moci stáhnout nejnovější verzi „DECLARATION OF CONFORMITY (PROHLÁŠENÍ O SHODĚ)“ (DoC).</p>
Danish	<p>Herved erklærer Panasonic Corporation, at radioudstyret af typen nævnt ovenfor er i overensstemmelse med direktiv 2014/53/EU.</p> <p>Du kan hente den seneste "DECLARATION OF CONFORMITY (OVERENSSTEMMELSESERKLÆRING)" (DoC) ved at besøge http://www.ptc.panasonic.eu/, klikke på "Declaration of Conformity (Overensstemmelseerklæring)" og indtaste nedensående nøgleord i feltet til nøgleordssøgning.</p> <p>Nøgleord: CQ-TMBC04M</p>
German	<p>Hiermit erklärt Panasonic Corporation, dass der obengenannte Funknagel typ der Richtlinie 2014/53/EU entspricht.</p> <p>Klicken Sie unter http://www.ptc.panasonic.eu/ auf „Declaration of Conformity“ (Konformitätserklärung), geben Sie das nachstehende Schlüsselwort in die Schlüsselwortsuche ein und laden Sie die aktuelle „DECLARATION OF CONFORMITY (Konformitätserklärung)“ (DoC) herunter.</p> <p>Schlüsselwort: CQ-TMBC04M</p>
Greek	<p>Με την παρούσα, η Panasonic Corporation δηλώνει το ραδιοεξοπλισμός που παρατίθεται και η μ συσκευών να είναι εν συνάρτηση με την οδηγία 2014/53/ΕΕ.</p> <p>Ελ σκεθθήτε εν σφ πολίητο http://www.ptc.panasonic.eu/, κλίντε κλίσ στο «Declaration of Conformity (Δήλωση συμμόρφωσης)», καταγράστε εν παρούσα κ έθελθθ στο πλάσο αναί ποίς, κ έθελθθ ταν για να κατέθ έστε εν π ο πρ σφάση «DECLARATION OF CONFORMITY (ΔΗΛΩΣΗ ΣΥΜΜΟΡΦΩΣΗΣ)» (DoC).</p> <p>Κ έθελθθ CQ-TMBC04M</p>
English	<p>Hereby, Panasonic Corporation declares that the radio equipment type Listed above is in compliance with Directive 2014/53/EU.</p> <p>Access to http://www.ptc.panasonic.eu/, click "Declaration of Conformity", enter the below Keyword into the keyword search box, you can download the latest "DECLARATION OF CONFORMITY" (DoC).</p> <p>Keyword: CQ-TMBC04M</p>
Spanish	<p>Por la presente, Panasonic Corporation declara que el equipo de radio del tipo citado más arriba cumple con lo establecido en la Directiva 2014/53/UE.</p> <p>Acceda a http://www.ptc.panasonic.eu/, haga clic en "Declaration of Conformity (Declaración de conformidad)", introduzca la palabra clave indicada a continuación en el cuadro de búsqueda y podrá descargar la última "DECLARATION OF CONFORMITY (Declaración de conformidad)" (DoC).</p> <p>Palabra clave: CQ-TMBC04M</p>
Estonia	<p>Käesolevaks deklareerib Panasonic Corporation, et eelmainitud raadioseadme tüüp vastab direktiivi 2014/53/EÜ nõuetele.</p> <p>Ming eesbilehele http://www.ptc.panasonic.eu/, klõpsake välkult „Declaration of Conformity“ (Vastavusdeklaratsioon), sisestage alltoodud märksõna spetsiaalse otsing väljale ning laadige alla dokumendi „DECLARATION OF CONFORMITY“ (Vastavusdeklaratsioon) (DoC) viimane versioon.</p> <p>Märksõna: CQ-TMBC04M</p>

Finnish	<p>Panasonic Corporation vakuuttaa, että edellä lueteltu radiolaitetyyppi täyttää direktiivissä 2014/53/EU asetetut vaatimukset.</p> <p>Vimeisin "DECLARATION of CONFORMITY (VAATIMUSTENMUKAISUUSVAKUUTUS)" (DoC) on ladattavissa verkkosivulla http://www.ptc.panasonic.eu/ valitsemalla kohta "Declaration of Conformity (vaatimustenmukaisuusvakuutus)" ja syöttämällä alle mainittu hakusana hakukenttään.</p> <p>Hakusana: CO-TMBCE04M</p>
French	<p>Par la présente, Panasonic Corporation déclare que le type d'équipement radio répertorié ci-dessous est en conformité avec la directive 2014/53/UE.</p> <p>Pour télécharger la dernière « DECLARATION of CONFORMITY (DÉCLARATION DE CONFORMITÉ) » (DoC), rendez-vous sur http://www.ptc.panasonic.eu/, cliquez sur « Declaration of Conformity (Déclaration de conformité) », puis saisissez le mot clé ci-dessous dans le champ de recherche par mots clés.</p> <p>Mot clé: CO-TMBCE04M</p>
Croatian	<p>Övime Panasonic Corporation izjavljaju da je navedena oprema vidno navedene iznad u skladu s Direktivom 2014/53/EU.</p> <p>Pristup za: http://www.ptc.panasonic.eu/ kliknite „Declaration of Conformity“ (izjava o sukladnosti), unesite ključnu riječ koja je navedena u nastavku, u okviru za pretraživanje ključne riječi, možete preuzeti najnoviju „DECLARATION of CONFORMITY (IZJAVA O SUKLADNOSTI)“ (DoC).</p> <p>Ključna riječ: CO-TMBCE04M</p>
Hungarian	<p>A Panasonic Corporation szívesen nyilatkozik arról, hogy a fent megadott típusú rádiós berendezés(ek) megfelel(nek) a 2014/53/EU irányelv előírásainak.</p> <p>Értesítjük a http://www.ptc.panasonic.eu/ oldalán, kattintson a „Declaration of Conformity” (Megfeleléségi nyilatkozat) elemre, és írja be az alábbi kulcsszót a kulcsszó keresőmezőbe, ha szeretné letölteni a legújabb „DECLARATION of CONFORMITY” (Megfeleléségi nyilatkozat) dokumentumot (doc-fáj).</p> <p>Kulcsszó: CO-TMBCE04M</p>
Iceland	<p>Hér með lýsir Panasonic Corporation þú yfir að órángreindur útlærslaþúdur er í samræmi við tiltekið 2014/53/ESB.</p> <p>Farið á http://www.ptc.panasonic.eu/ smelltu á „Declaration of Conformity (Samræmisvirkning)”, sláðu eftirfarandi tegundarnúmer inn í leitarniðir og þú áurðu sýnt.</p> <p>Þú gætst „DECLARATION of CONFORMITY (SAMRÆMISVIRKINGUNA)” (DoC).</p> <p>Tegundarnúmer: CO-TMBCE04M</p>
Italian	<p>Il fabbricante, Panasonic Corporation, dichiara che il tipo di apparecchio radio elencato sopra è conforme alla direttiva 2014/53/UE.</p> <p>Accedere al sito http://www.ptc.panasonic.eu/, fare clic su "Declaration of Conformity (Dichiarazione di Conformità)" e inserire la parola chiave seguita nella casella di ricerca per parole chiave per poter scaricare la "DECLARATION of CONFORMITY (Dichiarazione di Conformità)" (DoC) più recente.</p> <p>Parola chiave: CO-TMBCE04M</p>
Lithuanian	<p>Šiuo dokumentu „Panasonic Corporation“ pareiškia, kad pirmiau pateiktas tipo radijo įrenginys atitinka direktyvą 2014/53/ES.</p> <p>Atsisiųskite http://www.ptc.panasonic.eu/ puslapyje „Declaration of Conformity“ (Atitikties deklaracija), įrašykite žodį paieškos laukelyje ir paspauskite mygtuką „Atsisiųskite naujausią „DECLARATION of CONFORMITY“ (ATITIKTIES DEKLARACIJĄ)“.</p> <p>Raktažodis: CO-TMBCE04M</p>
Latvian	<p>Ar šis Panasonic Corporation deklarē, ka iepriekš minētais radioiekārtas atbilst Direktīvas 2014/53/ES prasībām.</p> <p>Doklētās uz vietas http://www.ptc.panasonic.eu/, noklikšķiniet uz sadaļas "Declaration of Conformity" (Atbilstības deklarācija) un atbilstošu meklēšanas lauku ievadiet turpmāk minēto atbilstošu vārdu, lai lejupielādētu jaunāko "DECLARATION of CONFORMITY (DoC)" (ATBILSTĪBAS DEKLARĀCIJU).</p> <p>Atbilstošais: CO-TMBCE04M</p>
Maltese	<p>Ħdan, Panasonic Corporation tiddikjara li tip ta' tagħmir tarrazzu elettroniku hawn fuq huwa konformi mad-Direttiva 2014/53/UE.</p> <p>Access għall-http://www.ptc.panasonic.eu/ ikklikja "Declaration of Conformity (Dikjarazzjoni ta' Konformità)", dan huwa il-Kelma Muflin ta' tagħmir tarrazzu ta' Hilem muflin, tista' tniżel id-"DECLARATION of CONFORMITY (DIKJARAZZJONI TA' KONFORMITÀ)" l-aktar riċenti (DoC).</p> <p>Kelma Muflin: CO-TMBCE04M</p>
Norway	<p>Panasonic Corporation erklærer herved at radioutrusten tyten nevnt ovenfor er i samsvar med direktiv 2014/53/EU.</p> <p>Ved å gå til http://www.ptc.panasonic.eu/ klikke på "Declaration of Conformity (samsvarserklæring)" og taste inn nedestående nøkkelord i søkkelordssøkeboksen, kan du laste ned den nyeste "DECLARATION of CONFORMITY (SAMSVARSEKRLÆRINGEN)" (DoC).</p> <p>Nøkkelord: CO-TMBCE04M</p>
Dutch	<p>Hierbij verklaart, Panasonic Corporation, dat radioapparatuur van het hierboven vermelde type conform is met Richtlijn 2014/53/EU.</p> <p>Ga naar http://www.ptc.panasonic.eu/, klik op "Declaration of Conformity (conformiteitsverklaring)", vul in het vak Keyword Search de onderzande code in en dan kunt u de recentste "DECLARATION of CONFORMITY (conformiteitsverklaring)" (DoC) downloaden.</p> <p>Code: CO-TMBCE04M</p>

Specifications/Customer Information
Declaration of Conformity

Polish	<p>Niniejszym firma Panasonic oświadcza, że podany powyżej typ urządzeń radiowych jest zgodny z dyrektywą 2014/53/UE.</p> <p>Wejść na stronę http://www.ptc.panasonic.eu/, kliknij „Declaration of Conformity (Declaracja zgodności)”, w polu wyszukiwania słów kluczowych wprowadź podane poniżej słowo kluczowe i pobierz najnowszą wersję „DECLARATION of CONFORMITY (DEKLARACJA ZGODNOŚCI)” (DoC).</p> <p>Słowo kluczowe: CQ-TM6CE04M</p>
Portuguese	<p>Pela presente, a Panasonic Corporation declara que o equipamento de rádio do tipo listado acima se encontra em conformidade com a Diretiva 2014/53/UE.</p> <p>Aceda a http://www.ptc.panasonic.eu/, clique em “Declaration of Conformity (Declaração de Conformidade)”;</p> <p>Introduza a palavra-chave indicada abaixo na caixa de pesquisa de palavras-chave para descarregar a mais recente “DECLARATION of CONFORMITY (DECLARAÇÃO DE CONFORMIDADE)” (DoC).</p> <p>Palavra-chave: CQ-TM6CE04M</p>
Romanian	<p>Prin prezentul document, Panasonic Corporation declară că echipamentul radio de tipul enumerat mai sus este în conformitate cu Directiva 2014/53/UE.</p> <p>Accesați http://www.ptc.panasonic.eu/, faceți clic pe „Declaration of Conformity (Declarație de conformitate)”;</p> <p>Introduceți cuvântul cheie de mai jos în căsuța de căutare după cuvintele cheie și puteți să descărcați cea mai recentă „DECLARATION of CONFORMITY (DECLARAȚIE DE CONFORMITATE)” (DoC).</p> <p>Cuvântul cheie: CQ-TM6CE04M</p>
Serbia	<p>Ovim kompanija Panasonic Corporation izjavljuje da je ova navedena radio oprema tipa u skladu sa odredbama direktive 2014/53/UE.</p> <p>Pristupite stranici http://www.ptc.panasonic.eu/, kliknite na „Declaration of Conformity (Izjava o usklađenosti)”, dodeljenu ključnu reč unesite u polje za pretrag uključnih reči i onda možete da preuzmete najnoviji dokument „DECLARATION of CONFORMITY (Izjava o usklađenosti)” (DoC – izjava o usklađenosti).</p> <p>Ključna reč: CQ-TM6CE04M</p>
Slovak	<p>Spoločnosť Panasonic Corporation týmto vyhlasuje, že rádiové zariadenie vyššie uvedené typu je v súlade so smernicou 2014/53/EÚ.</p> <p>Na lokalite http://www.ptc.panasonic.eu/ môžete kliknúť na možnosť „Declaration of Conformity (Vyhlasenie o zhode)”, zadajte nižšie uvedené kľúčové slovo do vyhľadávacieho poľa a prevziať si najnovšie „DECLARATION of CONFORMITY (VYHLÁSENIE O ZHODE)” (DoC).</p> <p>Kľúčové slovo: CQ-TM6CE04M</p>
Slovene	<p>Panasonic Corporation potrjuje, da je zgoraj navedeni tip radijske opreme skladen z Direktivo 2014/53/UE.</p> <p>Obiščite http://www.ptc.panasonic.eu/, kliknite “Declaration of Conformity (Izjava o skladnosti)”, v okence za iskanje vnesite spodnjo ključno besedo in prenesite najnovjšo Izjavo o skladnosti – “DECLARATION of CONFORMITY (IZJAVA O SKLADNOSTI)” (DoC).</p> <p>Ključna beseda: CQ-TM6CE04M</p>
Swedish	<p>Härmed intyg av Panasonic Corporation att radioutrustning erovan uppfyller direktiv 2014/53/UE.</p> <p>Gå till http://www.ptc.panasonic.eu/, klicka på “Declaration of Conformity (försäkran om överensstämmelse)” och ang enyckelordet nedan i sökrutan. Sedan kan du ladda ned den senaste “DECLARATION of CONFORMITY (försäkran om överensstämmelse)” (DoC).</p> <p>Nyckelord: CQ-TM6CE04M</p>
Turkey	<p>İşbu belge ile Panasonic Corporation, yukarıda listelenen radyo ekipmanı tipinin 2014/53/AB Direktifine uyur olduğunu beyan etmektedir.</p> <p>http://www.ptc.panasonic.eu/ adresinden “Declaration of Conformity (Uygünlük beyanı)” başlığına tıklayarak sonra, aşağıdaki anahtar kelimeyi arama kutusuna girerek en son “DECLARATION of CONFORMITY (UYGÜNLÜK BEYANI)”nı (DoC) indirebilirsiniz.</p> <p>Anahtar kelime: CQ-TM6CE04M</p>

Without DAB radio

Manufacture, Address:

Üretici, Adres:

Prodhimi, Adresa:

Panasonic Corporation.

4261 Ikonobe-cho, Tsuzuki-ku, Yokohama-City Kanagawa-ken 224-8520, Japan

Importer, Address:

İthalatçı, Adres:

Importuesi, Adresa:

Mazda Motor Logistics Europe NV

Blaasveldstraat 162, 2830 Willebroek, België

Mazda Motor Poland sp.zo.o.

ul. Postępu 14B, 02-676 Warsaw, Poland

Mazda Motor Czech, s.r.o.

Türkova 2319/5b, Chodov, 149 00 Prague 4, Czech Republic

Mazda Motor Slovakia, s.r.o.

LINDNER II, Galvaniho 7/B, Bratislava – Ružinov 821 04, Slovak Republic

Model. No.: CQ-TM6CE14M

Specifications/Customer Information
Declaration of Conformity

Albania	<p>Me anë të këtij dokumenti, "Panasonic Corporation" deklaron se radio pajisja e tipit të listuar më lart është në përputhshmëri me Direktivën 2014/53/EU.</p> <p>Hyrni në http://www.ptc.panasonic.eu/, klikoni "Declaration of Conformity (Deklarata e përputhshmërisë)", shkruani termin kyç në kutinë e kërkimit të temave kyçe dhe mund të shkarkoni versionin e fundit të "DECLARATION OF CONFORMITY (DEKLARATËN E PËRPUTHSHMËRISË)" (DoC).</p> <p>Termi kyç: CQ-TM6CE14M</p>
Bulgarian	<p>С настоящото Panasonic Corporation декларира, че радиооборудването от типа, посочен по-горе, е в съответствие с Директива 2014/53/EU.</p> <p>Отидете на http://www.ptc.panasonic.eu/, щракнете върху „Declaration of Conformity (Декларация за съответствие)“, въведете ключовата дума, дадена по-долу, в полето за търсене по ключова дума и ще можете да изтеглите най-новата „DECLARATION OF CONFORMITY (ДЕКЛАРАЦИЯ ЗА СЪОТВЕТСТВИЕ)“ (DoC).</p> <p>Ключова дума: CQ-TM6CE14M</p>
Czech	<p>Tímto společnost Panasonic Corporation prohlašuje, že výše uvedeně radiové zařízení typu CQ-TM6CE14M je v souladu se směrnicí 2014/53/EU.</p> <p>Když přejdete na stránku http://www.ptc.panasonic.eu/, kliknete na „Declaration of Conformity (Prohlášení o shodě)“ a zadáte číslo modelu CQ-TM6CE14M do pole pro vyhledávání podle klíčového slova, budete si moci stáhnout nejnovější verzi „DECLARATION OF CONFORMITY (PROHLÁŠENÍ O SHODĚ)“ (DoC).</p>
Danish	<p>Hermed erklærer Panasonic Corporation, at radioudstyret af typen nævnt ovenfor er i overensstemmelse med direktiv 2014/53/EU.</p> <p>Du kan hente den seneste "DECLARATION OF CONFORMITY (OVERENSSTEMMELSESERKLÆRING)" (DoC) ved at besøge http://www.ptc.panasonic.eu/, klikke på "Declaration of Conformity (Overensstemmelseserklæring)" og indtaste nedenstående nøgleord i feltet til nøgleordsøgning.</p> <p>Nøgleord: CQ-TM6CE14M</p>
German	<p>Hiermit erklärt Panasonic Corporation, dass der obengenannte Funkanlagentyp der Richtlinie 2014/53/EU entspricht.</p> <p>Klicken Sie unter <a "="" href="http://www.ptc.panasonic.eu/auf„Declaration of Conformity“ (Konformitätserklärung), geben Sie das nachstehende Schlüsselwort in die Schlüsselwortsuche ein und laden Sie die aktuelle „DECLARATION OF CONFORMITY (Konformitätserklärung)“ (DoC) herunter.</p> <p>Schlüsselwort: CQ-TM6CE14M</p> </td> </tr> <tr> <td>Greek</td> <td> <p>Με την παρούσα η Panasonic Corporation δηλώνει το ραδιοεξοπλισμό που παραθέτουμε να συμμορφώνεται με την οδηγία 2014/53/ΕΕ.</p> <p>Επισκεφθείτε τον σελ http://www.ptc.panasonic.eu/, κάντε κλικ στο „Declaration of Conformity (Δήλωση συμμόρφωσης)“, εισαγάγετε την παρούσα λέξη-κλειδί στο πλαίσιο αναζήτησης λέξης-κλειδί για να μπορέσετε να κατεβάσετε την πιο πρόσφατη „DECLARATION OF CONFORMITY (ΔΗΛΩΣΗ ΣΥΜΜΟΡΦΩΣΗΣ)“ (DoC).</p> <p>Λέξη-κλειδί: CQ-TM6CE14M</p>
English	<p>Hereby, Panasonic Corporation declares that the radio equipment type Listed above is in compliance with Directive 2014/53/EU.</p> <p>Access to http://www.ptc.panasonic.eu/, click "Declaration of Conformity", enter the below Keyword into the keyword search box, you can download the latest "DECLARATION OF CONFORMITY" (DoC).</p> <p>Keyword: CQ-TM6CE14M</p>
Spanish	<p>Por la presente, Panasonic Corporation declara que el equipo de radio del tipo citado más arriba cumple con lo establecido en la Directiva 2014/53/UE.</p> <p>Acceda a http://www.ptc.panasonic.eu/, haga clic en "Declaration of Conformity (Declaración de conformidad)", introduzca la palabra clave indicada a continuación en el cuadro de búsqueda y podrá descargar la última "DECLARATION OF CONFORMITY (Declaración de conformidad)" (DoC).</p> <p>Palabra clave: CQ-TM6CE14M</p>
Estonia	<p>Käesolevaks deklareerb Panasonic Corporation, et eelmainitud raadioseadme tüüp vastab direktiivi 2014/53/EU nõuetele.</p> <p>Ming soovilehele http://www.ptc.panasonic.eu/, klõpsake välkuli „Declaration of Conformity“ (Vastavusdeklaratsioon), sisestage alltoodud märksõna spetsiaalse otsing väljale ning laadige alla dokumenti „DECLARATION OF CONFORMITY“ (Vastavusdeklaratsioon) (DoC) viimase versioon.</p> <p>Märksõna: CQ-TM6CE14M</p>

<p>Finnish</p>	<p>Panasonic Corporation vakuuttaa, että edellä lueteltu radiolaitetyyppi täyttää direktiivissä 2014/53/EU asetetut vaatimukset</p> <p>Väiteisin "DECLARATION OF CONFORMITY (VAATIMUSTENMUKAISUUSVAKUUTUS)" (DoC) on ladattavissa verkkosivulla http://www.ptc.panasonic.eu/</p> <p>yllälistämällä kohta "Declaration of Conformity (vaatimustenmukaisuusvakuutus)" ja syöttämällä alla mainittu hakusana hakukenttään.</p> <p>Hakusana: CO-TM6CE14M</p>
<p>French</p>	<p>Par la présente, Panasonic Corporation déclare que le type d'équipement radio répertorié ci-dessus est en conformité avec la directive 2014/53/UE.</p> <p>Pour télécharger le document « DECLARATION OF CONFORMITY (DÉCLARATION DE CONFORMITÉ) » (DoC), rendez-vous sur http://www.ptc.panasonic.eu/, cliquez sur « Declaration of Conformity (Déclaration de conformité) », puis saisissez le mot clé ci-dessus dans le champ de recherche par mots clés.</p> <p>Mot-clé : CO-TM6CE14M</p>
<p>Croatian</p>	<p>Övime Panasonic Corporation izjavljuje da je radijska oprema vrste navedene iznad u skladu s Direktivom 2014/53/EU.</p> <p>Pristup za: http://www.ptc.panasonic.eu/, kliknite „Declaration of Conformity“ (Izjava o sukladnosti), unesite ključnu riječ koja je navedena u nastavku, u okviru za pretraživanje ključne riječi, možete preuzeti najnoviju „DECLARATION OF CONFORMITY (IZJAVA O SUKLADNOSTI)“ (DoC).</p> <p>Ključna riječ: CO-TM6CE14M</p>
<p>Hungarian</p>	<p>A Panasonic Corporation ezennel nyilatkozik arról, hogy a fent megadott típusú rádiós berendezés(ek) megfelel(nek) a 2014/53/EU irányelv előírásainak.</p> <p>Lépjön a http://www.ptc.panasonic.eu/ oldalra, kattintson a „Declaration of Conformity“ (Megfelelőségi nyilatkozat) elemre, és írja be az alábbi Kulcsszót a kulcsszó keresőmezőbe, ha szeretné letölteni a legújabb „DECLARATION OF CONFORMITY“ (Megfelelőségi nyilatkozat) dokumentumot (doctag).</p> <p>Kulcsszó: CO-TM6CE14M</p>
<p>Icelandic</p>	<p>Hér með lýsir Panasonic Corporation því yfir á öfbrigðisindur útvörum únaður er í samræmi við tilskilin 2014/53/ESB.</p> <p>Firðu á http://www.ptc.panasonic.eu/ smelltu á „Declaration of Conformity (Samræmisvörðun)“.</p> <p>CO-TM6CE14M not séu undanfærðir inn í leitarreit og þú getur sáðu eftir.</p> <p>Í justu „DECLARATION OF CONFORMITY (SAMRÆMISYFIRLÝSINGUNA)“ (DoC).</p> <p>Tegundamer: CO-TM6CE14M</p>
<p>Italian</p>	<p>Il fabbricante, Panasonic Corporation, dichiara che il tipo di apparecchio radio elencato sopra è conforme alla direttiva 2014/53/UE.</p> <p>Accedere al sito http://www.ptc.panasonic.eu/, fare clic su "Declaration of Conformity (Dichiarazione di Conformità)" e inserire la parola chiave seguita nella casella di ricerca per parole chiave per poter scaricare la "DECLARATION OF CONFORMITY (Dichiarazione di Conformità)" (DoC) più recente.</p> <p>Parola chiave: CO-TM6CE14M</p>
<p>Lithuanian</p>	<p>Šiuo dokumentu „Panasonic Corporation“ pareiškia, kad pirmiau pateiktas tipo radijo ryšio įrenginys atitinka direktyvą 2014/53/ES.</p> <p>Atsivirkite http://www.ptc.panasonic.eu/ puslapyje klaukite „Declaration of Conformity“ (Atitikties deklaracija), įrašykite žodį paieškos laukelyje įveskite toliau pateiktą raktažodį ir spauskite paieškos mygtuką „DECLARATION OF CONFORMITY“ (ATITIKTIES DEKLARACIJA)</p> <p>Raktažodis: CO-TM6CE14M</p>
<p>Latvian</p>	<p>Ar šis Panasonic Corporation deklarē, ka iepriekš minētais radioiekārtu atbilst Direktīvas 2014/53/ES prasībām.</p> <p>Dotiesies uz vietni http://www.ptc.panasonic.eu/, noklikšķiniet uz sadales „Declaration of Conformity“ (Atbilstības deklarācija) un atbilstošu meklēšanas lauku ievadiet turpmāk minēto atbilstošu, lai lejupielādētu jaunāko „DECLARATION OF CONFORMITY (DoC)“ (ATBILSTĪBAS DEKLARĀCIJU).</p> <p>Atbilstošs: CO-TM6CE14M</p>
<p>Maltese</p>	<p>Bydan, Panasonic Corporation iddikjara li tip ta' tagħmir tar-radju elenkat hawn fuq huwa konformi mad-Direttiva 2014/53/UE.</p> <p>Access għall-http://www.ptc.panasonic.eu/ il-ikkinja "Declaration of Conformity (Dikjarazzjoni ta' Konformità)", għal li-Kelma Muftiethawn ta' li-parti tar-rerarka tal-kliem muftiethawn ta' biżżejjed id-"DECLARATION OF CONFORMITY (DIKJARAZZJONI TA' KONFORMITÀ)" Iskrar nienti (DoC).</p> <p>Kelma Muftieth: CO-TM6CE14M</p>
<p>Norway</p>	<p>Panasonic Corporation erklærer herved at radioutstyret av typen nevnt ovenfor er i samsvar med direktiv 2014/53/EU.</p> <p>Ved å gå til http://www.ptc.panasonic.eu/, klikke på "Declaration of Conformity (samsvarserklæring)" og taste inn nedensstående nøkkelord i søkefeltet.</p> <p>Nøkkelord: "DECLARATION OF CONFORMITY (SAMSVARSERKLÆRINGEN)" (DoC).</p> <p>Nøkkelord: CO-TM6CE14M</p>
<p>Dutch</p>	<p>Hierbij verklaart, Panasonic Corporation, dat radioapparatuur van het hierboven vermelde type conform is met Richtlijn 2014/53/EU.</p> <p>Ga naar http://www.ptc.panasonic.eu/, klik op "Declaration of Conformity (conformiteitsverklaring)", vul in het veld Keyword Search de ordersaende code in en dan kunt u de recentste "DECLARATION OF CONFORMITY (conformiteitsverklaring)" (DoC) downloaden.</p> <p>Code: CO-TM6CE14M</p>

Specifications/Customer Information
Declaration of Conformity

Polish	<p>Niniejszym firma Panasonic oświadcza, że podany powyżej typ urządzeń radiowych jest zgodny z dyrektywą 2014/53/UE.</p> <p>Wejść na stronę http://www.ptc.panasonic.eu/, kliknij „Declaration of Conformity (Deklaracja zgodności)”, w polu wyszukiwania słów kluczowych wprowadź podane poniżej słowo kluczowe i pobierz najnowszy wersję „DECLARATION of CONFORMITY (DEKLARACJA ZGODNOŚCI)” (DoC).</p> <p>Słowo kluczowe: CQ-TM6CE14M</p>
Portuguese	<p>Para presente, a Panasonic Corporation declara que o equipamento de rádio do tipo listado acima se encontra em conformidade com a Diretiva 2014/53/UE.</p> <p>Acceda a http://www.ptc.panasonic.eu/, clique em “Declaration of Conformity (Declaração de Conformidade)”, introduza a palavra-chave indicada abaixo na caixa de pesquisa de palavras-chave para descarregar a mais recente “DECLARATION of CONFORMITY (DECLARAÇÃO DE CONFORMIDADE)” (DoC).</p> <p>Palavra-chave: CQ-TM6CE14M</p>
Romanian	<p>Prin prezentul document, Panasonic Corporation declară că echipamentul radio de tipul enumerat mai sus este în conformitate cu Directiva 2014/53/UE.</p> <p>Accesați http://www.ptc.panasonic.eu/, faceți clic pe „Declaration of Conformity (Declarația de conformitate)”, introduceți cuvântul cheie de mai jos în căsuța de căutare după cuvintele cheie și puteți să descărcați cea mai recentă „DECLARATION of CONFORMITY (DECLARAȚIE DE CONFORMITATE)” (DoC).</p> <p>Cuvânt cheie: CQ-TM6CE14M</p>
Serbia	<p>Ovim kompanija Panasonic Corporation izjavljuje da je ova navedena radio oprema tipa u skladu sa odredbama direktive 2014/53/UE.</p> <p>Pristupite stranici http://www.ptc.panasonic.eu/, kliknite na „Declaration of Conformity (Izjava o usklađenosti)”, dodeljenu ključnu reč unesite u polje za pretraživanje ključnih reči i onda možete da preuzmete najnoviji dokument „DECLARATION of CONFORMITY (Izjava o usklađenosti)” (DoC – izjava o usklađenosti).</p> <p>Ključna reč: CQ-TM6CE14M</p>
Slovak	<p>Spoločnosť Panasonic Corporation týmto vyhlasuje, že rádiové zariadenie vyššie uvedené typu je v súlade so smernicou 2014/53/EÚ.</p> <p>Na lokalite http://www.ptc.panasonic.eu/ môžete kliknúť na možnosť „Declaration of Conformity (Vyhlásenie o zhode)”, za dať nižšie uvedené kľúčové slovo do vyhľadávacieho poľa a prevziať si najnovšie „DECLARATION of CONFORMITY (VYHLÁSENIE O ZHODE)” (DoC).</p> <p>Kľúčové slovo: CQ-TM6CE14M</p>
Slovene	<p>Panasonic Corporation potrjuje, da je zgoraj navedeni tip radijske opreme skladen z Direktivo 2014/53/UE.</p> <p>Obiščite http://www.ptc.panasonic.eu/, kliknite “Declaration of Conformity (Izjava o skladnosti)”, v okence za iskanje vnesite spodnjo ključno besedo in prenesite najnovjšo Izjavo o skladnosti – “DECLARATION of CONFORMITY (IZJAVA O SKLADNOSTI)” (DoC).</p> <p>Ključna beseda: CQ-TM6CE14M</p>
Swedish	<p>Härmed intyg av Panasonic Corporation att radioutrustning erovan uppfyller direktiv 2014/53/UE.</p> <p>Gå till http://www.ptc.panasonic.eu/, klicka på “Declaration of Conformity (Försäkran om överensstämmelse)” och ange nyckelordet nedan i sökrutan. Sedan kan du ladda ned den senaste “DECLARATION of CONFORMITY (Försäkran om överensstämmelse)” (DoC).</p> <p>Nyckelord: CQ-TM6CE14M</p>
Turkey	<p>İşbu belge ile Panasonic Corporation, yukarıda listelenen radyo ekipmanlarının 2014/53/AB Direktifine uygu olduğunu beyan etmektedir.</p> <p>http://www.ptc.panasonic.eu/ adresinden “Declaration of Conformity (Uygu tutuk beyanı)” başlığında tıklayarak sonra, aşağıdaki anahtar kelimeleri arama kutusuna girerek en son “DECLARATION of CONFORMITY (UYGUNLUK BEYANI)” ni (DoC) indirebilirsiniz.</p> <p>Anahtar kelime: CQ-TM6CE14M</p>

Emergency Call System

Information of the radio device: Type FT0127C

1. Name and postal address of the manufacturer

Name: DENSO TEN Limited
 Address: 2-28, Goshō-dori 1-chome, Hyogo-ku, Kobe,
 652-8510 Japan

2. Simplified EU declaration of conformity

С настоящото DENSO TEN Limited декларира, че този тип радиосъоръжение FT0127C е в съответствие с Директива 2014/53/ЕС.

Цялостният текст на ЕС декларацията за съответствие може да се намери на следния интернет адрес:

https://www.denso-ten.com/support/regulation/eu_doc/

Функция	Работна честотна лента	Максимална радиочестотна мощност
GSM	880~915 MHz	35dBm e.i.r.p.
	1710~1785 MHz	32dBm e.i.r.p.
UMTS	880~915 MHz	25dBm e.i.r.p.
	1710~1785 MHz	25dBm e.i.r.p.
	1920~1980 MHz	25dBm e.i.r.p.

Ovim putem, DENSO TEN Limited izjavljuje da je vrsta radio opreme FT0127C u saglasnosti s Direktivom 2014/53/EU.

Cijeli tekst EC deklaracije o usaglašenosti je dostupan na sljedećoj internetskoj adresi:

https://www.denso-ten.com/support/regulation/eu_doc/

Funkcija	Radni frekvencijski pojas	Maksimalna radiofrekvencijska snaga
GSM	880~915 MHz	35dBm e.i.r.p.
	1710~1785 MHz	32dBm e.i.r.p.
UMTS	880~915 MHz	25dBm e.i.r.p.
	1710~1785 MHz	25dBm e.i.r.p.
	1920~1980 MHz	25dBm e.i.r.p.

Declaration of Conformity

Tímto DENSO TEN Limited prohlašuje, že typ rádiového zařízení FT0127C je v souladu se směrnicí 2014/53/EU.

Úplné znění EU prohlášení o shodě je k dispozici na této internetové adrese:

https://www.denso-ten.com/support/regulation/eu_doc/

Funkce	Provozní frekvenční pásma	Maximální radiofrekvenční výkon
GSM	880~915 MHz	35dBm e.i.r.p.
	1710~1785 MHz	32dBm e.i.r.p.
UMTS	880~915 MHz	25dBm e.i.r.p.
	1710~1785 MHz	25dBm e.i.r.p.
	1920~1980 MHz	25dBm e.i.r.p.

Hermed erklærer DENSO TEN Limited, at radioudstyrstypen FT0127C er i overensstemmelse med direktiv 2014/53/EU.

EU-overensstemmelseserklæringens fulde tekst kan findes på følgende internetadresse:

https://www.denso-ten.com/support/regulation/eu_doc/

Funktion	Driftsfrekvensbandet	Maksimal radio-frekvens effekt
GSM	880~915 MHz	35dBm e.i.r.p.
	1710~1785 MHz	32dBm e.i.r.p.
UMTS	880~915 MHz	25dBm e.i.r.p.
	1710~1785 MHz	25dBm e.i.r.p.
	1920~1980 MHz	25dBm e.i.r.p.

Hiermit erklart DENSO TEN Limited, dass der Funkanlagentyp FT0127C der Richtlinie 2014/53/EU entspricht.

Der vollständige Text der EU-Konformitätserklärung ist unter der folgenden Internetadresse verfügbar:

https://www.denso-ten.com/support/regulation/eu_doc/

Funktion	Betriebsfrequenzband	Maximale Hochfrequenzleistung
GSM	880~915 MHz	35dBm e.i.r.p.
	1710~1785 MHz	32dBm e.i.r.p.
UMTS	880~915 MHz	25dBm e.i.r.p.
	1710~1785 MHz	25dBm e.i.r.p.
	1920~1980 MHz	25dBm e.i.r.p.

Declaration of Conformity

Με την παρούσα ο/η DENSO TEN Limited, δηλώνει ότι ο ραδιοεξοπλισμός FT0127C πληροί την οδηγία 2014/53/ΕΕ.
Το πλήρες κείμενο της δήλωσης συμμόρφωσης ΕΕ διατίθεται στην ακόλουθη ιστοσελίδα στο διαδίκτυο:
https://www.denso-ten.com/support/regulation/eu_doc/

Λειτουργία	Ζώνη συχνοτήτων λειτουργίας	Μέγιστη ισχύς ραδιοσυχνότητας
GSM	880~915 MHz 1710~1785 MHz	35dBm e.i.r.p. 32dBm e.i.r.p.
UMTS	880~915 MHz 1710~1785 MHz 1920~1980 MHz	25dBm e.i.r.p. 25dBm e.i.r.p. 25dBm e.i.r.p.

Hereby, DENSO TEN Limited declares that the radio equipment type FT0127C is in compliance with Directive 2014/53/EU.
The full text of the EU declaration of conformity is available at the following internet address:
https://www.denso-ten.com/support/regulation/eu_doc/

Function	Operating frequency band	Maximum radio-frequency power
GSM	880~915 MHz 1710~1785 MHz	35dBm e.i.r.p. 32dBm e.i.r.p.
UMTS	880~915 MHz 1710~1785 MHz 1920~1980 MHz	25dBm e.i.r.p. 25dBm e.i.r.p. 25dBm e.i.r.p.

Por la presente, DENSO TEN Limited declara que el tipo de equipo radioeléctrico FT0127C es conforme con la Directiva 2014/53/UE.
El texto completo de la declaración UE de conformidad está disponible en la dirección Internet siguiente:
https://www.denso-ten.com/support/regulation/eu_doc/

Función	Banda de frecuencia operativa	Potencia máxima de la radiofrecuencia
GSM	880~915 MHz 1710~1785 MHz	35dBm e.i.r.p. 32dBm e.i.r.p.
UMTS	880~915 MHz 1710~1785 MHz 1920~1980 MHz	25dBm e.i.r.p. 25dBm e.i.r.p. 25dBm e.i.r.p.

Declaration of Conformity

Käesolevaga deklareerib DENSO TEN Limited, et käesolev raadioseadme tüüp FT0127C vastab direktiivi 2014/53/EL nõuetele. ELi vastavusdeklaratsiooni täielik tekst on kättesaadav järgmisel internetiaadressil:
https://www.denso-ten.com/support/regulation/eu_doc/

Funktsioon	Töösageduse lainela	Maksimaalne raadiosageduslik võimsus
GSM	880~915 MHz	35dBm e.i.r.p.
	1710~1785 MHz	32dBm e.i.r.p.
UMTS	880~915 MHz	25dBm e.i.r.p.
	1710~1785 MHz	25dBm e.i.r.p.
	1920~1980 MHz	25dBm e.i.r.p.

DENSO TEN Limited vakuuttaa, että radiolaitetyyppi FT0127C on direktiivin 2014/53/EU mukainen. EU-vaatimustenmukaisuusvakuutuksen täysimittainen teksti on saatavilla seuraavassa internetosoitteessa:
https://www.denso-ten.com/support/regulation/eu_doc/

Toiminto	Toimintataajuuskaista	Maksimi radiotaajuusteho
GSM	880~915 MHz	35dBm e.i.r.p.
	1710~1785 MHz	32dBm e.i.r.p.
UMTS	880~915 MHz	25dBm e.i.r.p.
	1710~1785 MHz	25dBm e.i.r.p.
	1920~1980 MHz	25dBm e.i.r.p.

Le soussigné, DENSO TEN Limited, déclare que l'équipement radioélectrique du type FT0127C est conforme à la directive 2014/53/UE. Le texte complet de la déclaration UE de conformité est disponible à l'adresse internet suivante:

https://www.denso-ten.com/support/regulation/eu_doc/

Fonction	Bande de fréquence de fonctionnement	Puissance maximale de la radiofréquence
GSM	880~915 MHz	35dBm e.i.r.p.
	1710~1785 MHz	32dBm e.i.r.p.
UMTS	880~915 MHz	25dBm e.i.r.p.
	1710~1785 MHz	25dBm e.i.r.p.
	1920~1980 MHz	25dBm e.i.r.p.

Leis seo, dearbhaíonn DENSO TEN Limited go gcomhlíonann an cineál trealaimh raidió FT0127C Treoir 2014/53/EU.

Tá an téacs iomlán den dearbhú comhréireachta AE ar fáil ag an seoladh Idirlin seo a leanas:

https://www.denso-ten.com/support/regulation/eu_doc/

Feidhm	Banda minicíochta oibriúcháin	Uaschumhacht radaimhnicíochta
GSM	880~915 MHz	35dBm e.i.r.p.
	1710~1785 MHz	32dBm e.i.r.p.
UMTS	880~915 MHz	25dBm e.i.r.p.
	1710~1785 MHz	25dBm e.i.r.p.
	1920~1980 MHz	25dBm e.i.r.p.

DENSO TEN Limited ovime izjavlja da je radijska oprema tipa FT0127C u skladu s Direktivom 2014/53/EU.

Cjeloviti tekst EU izjave o sukladnosti dostupan je na sljedećoj internetskoj adresi:

https://www.denso-ten.com/support/regulation/eu_doc/

Funkcija	Radni frekvencijski pojas	Maksimalna radiofrekvencijska snaga
GSM	880~915 MHz	35dBm e.i.r.p.
	1710~1785 MHz	32dBm e.i.r.p.
UMTS	880~915 MHz	25dBm e.i.r.p.
	1710~1785 MHz	25dBm e.i.r.p.
	1920~1980 MHz	25dBm e.i.r.p.

DENSO TEN Limited igazolja, hogy a FT0127C típusú rádióberendezés megfelel a 2014/53/EU irányelvnek.

Az EU-megfelelőségi nyilatkozat teljes szövege elérhető a következő internetes címen:

https://www.denso-ten.com/support/regulation/eu_doc/

Funkció	Üzemi frekvencia-tartomány	Maximális rádiófrekvenciás teljesítmény
GSM	880~915 MHz	35dBm e.i.r.p.
	1710~1785 MHz	32dBm e.i.r.p.
UMTS	880~915 MHz	25dBm e.i.r.p.
	1710~1785 MHz	25dBm e.i.r.p.
	1920~1980 MHz	25dBm e.i.r.p.

Declaration of Conformity

Hér með, lýsir DENSO TEN Limited því yfir að gerð útværpsbúnaðarins FT0127C samræmist tilskipun 2014/53/EU.

Allur texti ESB-samræmisýfirlýsingarinnar er aðgengilegur á eftirfarandi veffangi:

https://www.denso-ten.com/support/regulation/eu_doc/

Aðgerð	Notkunartíðni hljómsveit	Hámarks útværp-tíðni vald
GSM	880~915 MHz	35dBm e.i.r.p.
	1710~1785 MHz	32dBm e.i.r.p.
UMTS	880~915 MHz	25dBm e.i.r.p.
	1710~1785 MHz	25dBm e.i.r.p.
	1920~1980 MHz	25dBm e.i.r.p.

Il fabbricante, DENSO TEN Limited, dichiara che il tipo di apparecchiatura radio FT0127C è conforme alla direttiva 2014/53/UE.

Il testo completo della dichiarazione di conformità UE è disponibile al seguente indirizzo Internet:

https://www.denso-ten.com/support/regulation/eu_doc/

Funzione	Frequenza operativa	Massima potenza a radiofrequenza
GSM	880~915 MHz	35dBm e.i.r.p.
	1710~1785 MHz	32dBm e.i.r.p.
UMTS	880~915 MHz	25dBm e.i.r.p.
	1710~1785 MHz	25dBm e.i.r.p.
	1920~1980 MHz	25dBm e.i.r.p.

Aš, DENSO TEN Limited, patvirtinu, kad radijo įrenginių tipas FT0127C atitinka Direktyvą 2014/53/ES.

Visas ES atitikties deklaracijos tekstas prieinamas šiuo interneto adresu:

https://www.denso-ten.com/support/regulation/eu_doc/

Funkcija	Veikimo dažnių juosta	Maksimalus radijo dažnių galingumas
GSM	880~915 MHz	35dBm e.i.r.p.
	1710~1785 MHz	32dBm e.i.r.p.
UMTS	880~915 MHz	25dBm e.i.r.p.
	1710~1785 MHz	25dBm e.i.r.p.
	1920~1980 MHz	25dBm e.i.r.p.

Ar šo DENSO TEN Limited deklarē, ka radioiekārta FT0127C atbilst Direktīvai 2014/53/ES.

Pilns ES atbilstības deklarācijas teksts ir pieejams šādā interneta vietnē:
https://www.denso-ten.com/support/regulation/eu_doc/

Funkcija	Darba frekvences josla	Maksimālā radiofrekvences jauda
GSM	880~915 MHz	35dBm e.i.r.p.
	1710~1785 MHz	32dBm e.i.r.p.
UMTS	880~915 MHz	25dBm e.i.r.p.
	1710~1785 MHz	25dBm e.i.r.p.
	1920~1980 MHz	25dBm e.i.r.p.

Со ова, DENSO TEN Limited изјавува дека радио опремата од типот FT0127C е во согласност со Директивата 2014/53/EU.

Целиот текст на ЕУ изјавата за сообразност е достапен на следната интернет адреса:

https://www.denso-ten.com/support/regulation/eu_doc/

Функција	Работен фреквенциски опсег	Максимална радио-фреквенциска моќ
GSM	880~915 MHz	35dBm e.i.r.p.
	1710~1785 MHz	32dBm e.i.r.p.
UMTS	880~915 MHz	25dBm e.i.r.p.
	1710~1785 MHz	25dBm e.i.r.p.
	1920~1980 MHz	25dBm e.i.r.p.

Ovim, DENSO TEN Limited izjavljuje da je tip radio opreme FT0127C u skladu sa Direktivom 2014/53/EU.

Cjelokupan tekst EU deklaracije o usklađenosti dostupan je na sljedećoj internet adresi:

https://www.denso-ten.com/support/regulation/eu_doc/

Funkcija	Operativni frekvencijski opseg	Maksimalna jačina radio frekvencije
GSM	880~915 MHz	35dBm e.i.r.p.
	1710~1785 MHz	32dBm e.i.r.p.
UMTS	880~915 MHz	25dBm e.i.r.p.
	1710~1785 MHz	25dBm e.i.r.p.
	1920~1980 MHz	25dBm e.i.r.p.

Declaration of Conformity

B'dan, DENSO TEN Limited, niddikjara li dan it-tip ta' tagħmir tar-radju FT0127C huwa konformi mad-Direttiva 2014/53/UE.

It-test kollu tad-dikjarazzjoni ta' konformità tal-UE huwa disponibbli f'dan l-indirizz tal-Internet li ġej:

https://www.denso-ten.com/support/regulation/eu_doc/

Funzjoni	Band tal-frekwenza operattiva	I-energija massima bi frekwenza tar-radju
GSM	880~915 MHz	35dBm e.i.r.p.
	1710~1785 MHz	32dBm e.i.r.p.
UMTS	880~915 MHz	25dBm e.i.r.p.
	1710~1785 MHz	25dBm e.i.r.p.
	1920~1980 MHz	25dBm e.i.r.p.

Hierbij verklaar ik, DENSO TEN Limited, dat het type radioapparatuur FT0127C conform is met Richtlijn 2014/53/EU.

De volledige tekst van de EU-conformiteitsverklaring kan worden geraadpleegd op het volgende internetadres:

https://www.denso-ten.com/support/regulation/eu_doc/

Functie	Actieve frequentieband	Maximale radiofrequentie
GSM	880~915 MHz	35dBm e.i.r.p.
	1710~1785 MHz	32dBm e.i.r.p.
UMTS	880~915 MHz	25dBm e.i.r.p.
	1710~1785 MHz	25dBm e.i.r.p.
	1920~1980 MHz	25dBm e.i.r.p.

DENSO TEN Limited erklærer herved at radioutstyrstypen FT0127C er i samsvar med direktiv 2014/53/EU.

Den fullstendige teksten i EU-erklæringen er tilgjengelig på følgende internetadresse:

https://www.denso-ten.com/support/regulation/eu_doc/

Funksjon	Driftsfrekvensbånd	Maksimal radiofrekvent strøm
GSM	880~915 MHz	35dBm e.i.r.p.
	1710~1785 MHz	32dBm e.i.r.p.
UMTS	880~915 MHz	25dBm e.i.r.p.
	1710~1785 MHz	25dBm e.i.r.p.
	1920~1980 MHz	25dBm e.i.r.p.

Declaration of Conformity

DENSO TEN Limited niniejszym oświadcza, że typ urządzenia radiowego FT0127C jest zgodny z dyrektywą 2014/53/UE.

Pełny tekst deklaracji zgodności UE jest dostępny pod następującym adresem internetowym:

https://www.denso-ten.com/support/regulation/eu_doc/

Funkcja	Pasma częstotliwości pracy	Maksymalna moc częstotliwości radiowej
GSM	880~915 MHz	35dBm e.i.r.p.
	1710~1785 MHz	32dBm e.i.r.p.
UMTS	880~915 MHz	25dBm e.i.r.p.
	1710~1785 MHz	25dBm e.i.r.p.
	1920~1980 MHz	25dBm e.i.r.p.

O(a) abaixo assinado(a) DENSO TEN Limited declara que o presente tipo de equipamento de rádio FT0127C está em conformidade com a Diretiva 2014/53/UE.

O texto integral da declaração de conformidade está disponível no seguinte endereço de Internet:

https://www.denso-ten.com/support/regulation/eu_doc/

Função	Faixa de frequência operacional	Potência máxima de radiofrequência
GSM	880~915 MHz	35dBm e.i.r.p.
	1710~1785 MHz	32dBm e.i.r.p.
UMTS	880~915 MHz	25dBm e.i.r.p.
	1710~1785 MHz	25dBm e.i.r.p.
	1920~1980 MHz	25dBm e.i.r.p.

Prin prezenta, DENSO TEN Limited declară că tipul de echipamente radio FT0127C este în conformitate cu Directiva 2014/53/UE.

Textul integral al declarației UE de conformitate este disponibil la următoarea adresă internet:

https://www.denso-ten.com/support/regulation/eu_doc/

Funcție	Bandă de frecvență activă	Puterea maximă a radio-frecvenței
GSM	880~915 MHz	35dBm e.i.r.p.
	1710~1785 MHz	32dBm e.i.r.p.
UMTS	880~915 MHz	25dBm e.i.r.p.
	1710~1785 MHz	25dBm e.i.r.p.
	1920~1980 MHz	25dBm e.i.r.p.

Declaration of Conformity

DENSO TEN Limited tÿmto vyhlasuje, ÷e rãdiovÿ zariadenie typu FT0127C je v sÿlade so smernicou 2014/53/EÛ.

Ûplnÿ EÛ vyhlãsenie o zhode je k dispozicii na tejto internetovej adrese:
https://www.denso-ten.com/support/regulation/eu_doc/

Funkcia	Prevãdzkovÿ frekvenãné pãsma	Maximãlnÿ rãdiofrekvenãný vÿkon
GSM	880~915 MHz 1710~1785 MHz	35dBm e.i.r.p. 32dBm e.i.r.p.
UMTS	880~915 MHz 1710~1785 MHz 1920~1980 MHz	25dBm e.i.r.p. 25dBm e.i.r.p. 25dBm e.i.r.p.

DENSO TEN Limited potvrdzuje, da je typ rãdijske opreme FT0127C skladen z Direktivy 2014/53/EU.

Celotno besedilo izjave EU o skladnosti je na voljo na naslednjem spletnem naslovu:

https://www.denso-ten.com/support/regulation/eu_doc/

Funkcija	Delovni frekvenãni pas	Maksimalna rãdiofrekvenãna moã
GSM	880~915 MHz 1710~1785 MHz	35dBm e.i.r.p. 32dBm e.i.r.p.
UMTS	880~915 MHz 1710~1785 MHz 1920~1980 MHz	25dBm e.i.r.p. 25dBm e.i.r.p. 25dBm e.i.r.p.

Nÿpÿrjet kÿsaj, DENSO TEN Limited deklarirã se lloji i aparatit tÿ radios FT0127C ÷shtÿ nÿ pÿrputhje me Direktivÿn 2014/53/EU.

Teksti i plotÿ i deklarataÿ sÿ BE-sÿ mbi pÿrputhshmÿrinÿ ÷shtÿ i disponueshÿm nÿ adresÿn e mÿposhtme tÿ internetit:

https://www.denso-ten.com/support/regulation/eu_doc/

Funksion	Banda e frekuencÿs sÿ punÿs	Fuqia maksimale e frekuencave radio
GSM	880~915 MHz 1710~1785 MHz	35dBm e.i.r.p. 32dBm e.i.r.p.
UMTS	880~915 MHz 1710~1785 MHz 1920~1980 MHz	25dBm e.i.r.p. 25dBm e.i.r.p. 25dBm e.i.r.p.

Ovim, DENSO TEN Limited izjavljuje da je ovaj tip radijske opreme FT0127C u skladu sa odredbama Direktive 2014/53/EU. Kompletan tekst EU deklaracije o konformitetu je dostupan na sledećoj internet adresi:
https://www.denso-ten.com/support/regulation/eu_doc/

Funkcija	Radni frekvencijski pojas	Maksimalna radiofrekvencijska snaga
GSM	880~915 MHz	35dBm e.i.r.p.
	1710~1785 MHz	32dBm e.i.r.p.
UMTS	880~915 MHz	25dBm e.i.r.p.
	1710~1785 MHz	25dBm e.i.r.p.
	1920~1980 MHz	25dBm e.i.r.p.

Härmed försäkrar DENSO TEN Limited att denna typ av radioutrustning FT0127C överensstämmer med direktiv 2014/53/EU. Den fullständiga texten till EU-försäkran om överensstämmelse finns på följande webbadress:
https://www.denso-ten.com/support/regulation/eu_doc/

Funktion	Operationsfrekvensbandet	Maximal radiofrekvensseffekt
GSM	880~915 MHz	35dBm e.i.r.p.
	1710~1785 MHz	32dBm e.i.r.p.
UMTS	880~915 MHz	25dBm e.i.r.p.
	1710~1785 MHz	25dBm e.i.r.p.
	1920~1980 MHz	25dBm e.i.r.p.

DENSO TEN Limited, FT0127C türü telsiz ekipmanının 2014/53/EU Direktifine uygun olduğunu beyan etmektedir. AB uygunluk beyanının tam metnine aşağıdaki internet adresinden ulaşılabilir:
https://www.denso-ten.com/support/regulation/eu_doc/

İşlev	Çalışma frekans bandı	Maksimum radyo-frekans gücü
GSM	880~915 MHz	35dBm e.i.r.p.
	1710~1785 MHz	32dBm e.i.r.p.
UMTS	880~915 MHz	25dBm e.i.r.p.
	1710~1785 MHz	25dBm e.i.r.p.
	1920~1980 MHz	25dBm e.i.r.p.

Declaration of Conformity

Information of the radio device: Type TN0014D

1. Name and postal address of the manufacturer

Name: DENSO TEN Limited

Address: 2-28, Goshō-dori 1-chome, Hyogo-ku, Kobe,
652-8510 Japan

2. Simplified EU declaration of conformity

С настоящото DENSO TEN Limited декларира, че този тип радиосъоръжение TN0014D е в съответствие с Директива 2014/53/ЕС.

Цялостният текст на ЕС декларацията за съответствие може да се намери на следния интернет адрес:

https://www.denso-ten.com/support/regulation/eu_doc/

Функция	Работна честотна лента	Максимална радиочестотна мощност
GSM	880 - 915 MHz	32 dBm e.i.r.p.
	1710 - 1785 MHz	30 dBm e.i.r.p.
UMTS	880 - 915 MHz	24 dBm e.i.r.p.
	1920 - 1980 MHz	
LTE	832 - 862 MHz	24 dBm e.i.r.p.
	880 - 915 MHz	
	1710 - 1785 MHz	
	1920 - 1980 MHz	
	2500 - 2570 MHz	

Declaration of Conformity

Ovim putem, DENSO TEN Limited izjavljuje da je vrsta radio opreme TN0014D u saglasnosti s Direktivom 2014/53/EU.

Cijeli tekst EC deklaracije o usaglašenosti je dostupan na sljedećoj internetskoj adresi:

https://www.denso-ten.com/support/regulation/eu_doc/

Funkcija	Radni frekvencijski pojas	Maksimalna radiofrekvencijska snaga
GSM	880 - 915 MHz 1710 - 1785 MHz	32 dBm e.i.r.p. 30 dBm e.i.r.p.
UMTS	880 - 915 MHz 1920 - 1980 MHz	24 dBm e.i.r.p.
LTE	832 - 862 MHz 880 - 915 MHz 1710 - 1785 MHz 1920 - 1980 MHz 2500 - 2570 MHz	24 dBm e.i.r.p.

Tímto DENSO TEN Limited prohlašuje, že typ rádiového zařízení TN0014D je v souladu se směrnicí 2014/53/EU.

Úplné znění EU prohlášení o shodě je k dispozici na této internetové adrese:

https://www.denso-ten.com/support/regulation/eu_doc/

Funkce	Provozní frekvenční pásmu	Maximální radiofrekvenční výkon
GSM	880 - 915 MHz 1710 - 1785 MHz	32 dBm e.i.r.p. 30 dBm e.i.r.p.
UMTS	880 - 915 MHz 1920 - 1980 MHz	24 dBm e.i.r.p.
LTE	832 - 862 MHz 880 - 915 MHz 1710 - 1785 MHz 1920 - 1980 MHz 2500 - 2570 MHz	24 dBm e.i.r.p.

Declaration of Conformity

Hermed erklærer DENSO TEN Limited, at radioudstyrstypen TN0014D er i overensstemmelse med direktiv 2014/53/EU.

EU-overensstemmelseserklæringens fulde tekst kan findes på følgende internetadresse:

https://www.denso-ten.com/support/regulation/eu_doc/

Funktion	Driftsfrekvensbandet	Maksimal radio-frekvens effekt
GSM	880 - 915 MHz	32 dBm e.i.r.p.
	1710 - 1785 MHz	30 dBm e.i.r.p.
UMTS	880 - 915 MHz	24 dBm e.i.r.p.
	1920 - 1980 MHz	
LTE	832 - 862 MHz	24 dBm e.i.r.p.
	880 - 915 MHz	
	1710 - 1785 MHz	
	1920 - 1980 MHz	
	2500 - 2570 MHz	

Hiermit erklært DENSO TEN Limited, dass der Funkanlagentyp TN0014D der Richtlinie 2014/53/EU entspricht.

Der vollständige Text der EU-Konformitätserklärung ist unter der folgenden Internetadresse verfügbar:

https://www.denso-ten.com/support/regulation/eu_doc/

Funktion	Betriebsfrequenzband	Maximale Hochfrequenzleistung
GSM	880 - 915 MHz	32 dBm e.i.r.p.
	1710 - 1785 MHz	30 dBm e.i.r.p.
UMTS	880 - 915 MHz	24 dBm e.i.r.p.
	1920 - 1980 MHz	
LTE	832 - 862 MHz	24 dBm e.i.r.p.
	880 - 915 MHz	
	1710 - 1785 MHz	
	1920 - 1980 MHz	
	2500 - 2570 MHz	

Declaration of Conformity

Με την παρούσα ο/η DENSO TEN Limited, δηλώνει ότι ο ραδιοεξοπλισμός TN0014D πληροί την οδηγία 2014/53/EE.

Το πλήρες κείμενο της δήλωσης συμμόρφωσης ΕΕ διατίθεται στην ακόλουθη ιστοσελίδα στο διαδίκτυο:

https://www.denso-ten.com/support/regulation/eu_doc/

Λειτουργία	Ζώνη συχνοτήτων λειτουργίας	Μέγιστη ισχύς ραδιοσυχνότητας
GSM	880 - 915 MHz 1710 - 1785 MHz	32 dBm e.i.r.p. 30 dBm e.i.r.p.
UMTS	880 - 915 MHz 1920 - 1980 MHz	24 dBm e.i.r.p.
LTE	832 - 862 MHz 880 - 915 MHz 1710 - 1785 MHz 1920 - 1980 MHz 2500 - 2570 MHz	24 dBm e.i.r.p.

Hereby, DENSO TEN Limited declares that the radio equipment type TN0014D is in compliance with Directive 2014/53/EU.

The full text of the EU declaration of conformity is available at the following internet address:

https://www.denso-ten.com/support/regulation/eu_doc/

Function	Operating frequency band	Maximum radio-frequency power
GSM	880 - 915 MHz 1710 - 1785 MHz	32 dBm e.i.r.p. 30 dBm e.i.r.p.
UMTS	880 - 915 MHz 1920 - 1980 MHz	24 dBm e.i.r.p.
LTE	832 - 862 MHz 880 - 915 MHz 1710 - 1785 MHz 1920 - 1980 MHz 2500 - 2570 MHz	24 dBm e.i.r.p.

Declaration of Conformity

Por la presente, DENSO TEN Limited declara que el tipo de equipo radioeléctrico TN0014D es conforme con la Directiva 2014/53/UE.

El texto completo de la declaración UE de conformidad está disponible en la dirección Internet siguiente:

https://www.denso-ten.com/support/regulation/eu_doc/

Función	Banda de frecuencia operativa	Potencia máxima de la radiofrecuencia
GSM	880 - 915 MHz	32 dBm e.i.r.p.
	1710 - 1785 MHz	30 dBm e.i.r.p.
UMTS	880 - 915 MHz	24 dBm e.i.r.p.
	1920 - 1980 MHz	
LTE	832 - 862 MHz	24 dBm e.i.r.p.
	880 - 915 MHz	
	1710 - 1785 MHz	
	1920 - 1980 MHz	
	2500 - 2570 MHz	

Käesolevaga deklareerib DENSO TEN Limited, et käesolev raadioseadme tüüp TN0014D vastab direktiivi 2014/53/EL nõuetele.

ELi vastavusdeklaratsiooni täielik tekst on kättesaadav järgmisel internetiaadressil:

https://www.denso-ten.com/support/regulation/eu_doc/

Funktsioon	Töösageduse lainela	Maksimaalne raadiosageduslik võimsus
GSM	880 - 915 MHz	32 dBm e.i.r.p.
	1710 - 1785 MHz	30 dBm e.i.r.p.
UMTS	880 - 915 MHz	24 dBm e.i.r.p.
	1920 - 1980 MHz	
LTE	832 - 862 MHz	24 dBm e.i.r.p.
	880 - 915 MHz	
	1710 - 1785 MHz	
	1920 - 1980 MHz	
	2500 - 2570 MHz	

Declaration of Conformity

DENSO TEN Limited vakuuttaa, että radiolaitetyyppi TN0014D on direktiivin 2014/53/EU mukainen.
 EU-vaatimustenmukaisuusvakuutuksen täysimittainen teksti on saatavilla seuraavassa internetosoitteessa:
https://www.denso-ten.com/support/regulation/eu_doc/

Toiminto	Toimintataajuuskaista	Maksimi radiotaajuusteho
GSM	880 - 915 MHz	32 dBm e.i.r.p.
	1710 - 1785 MHz	30 dBm e.i.r.p.
UMTS	880 - 915 MHz	24 dBm e.i.r.p.
	1920 - 1980 MHz	
LTE	832 - 862 MHz	24 dBm e.i.r.p.
	880 - 915 MHz	
	1710 - 1785 MHz	
	1920 - 1980 MHz	
	2500 - 2570 MHz	

Le soussigné, DENSO TEN Limited, déclare que l'équipement radioélectrique du type TN0014D est conforme à la directive 2014/53/UE.
 Le texte complet de la déclaration UE de conformité est disponible à l'adresse internet suivante:
https://www.denso-ten.com/support/regulation/eu_doc/

Fonction	Bande de fréquence de fonctionnement	Puissance maximale de la radiofréquence
GSM	880 - 915 MHz	32 dBm e.i.r.p.
	1710 - 1785 MHz	30 dBm e.i.r.p.
UMTS	880 - 915 MHz	24 dBm e.i.r.p.
	1920 - 1980 MHz	
LTE	832 - 862 MHz	24 dBm e.i.r.p.
	880 - 915 MHz	
	1710 - 1785 MHz	
	1920 - 1980 MHz	
	2500 - 2570 MHz	

Declaration of Conformity

Leis seo, dearbhaíonn DENSO TEN Limited go gcomhlíonann an cineál trealamh raidió TN0014D Treoir 2014/53/EU.

Tá an téacs iomlán den dearbhú comhréireachta AE ar fáil ag an seoladh Idirlín seo a leanas:

https://www.denso-ten.com/support/regulation/eu_doc/

Feidhm	Banda minicíochta oibriúcháin	Uaschumhacht radaimhnicíochta
GSM	880 - 915 MHz 1710 - 1785 MHz	32 dBm e.i.r.p. 30 dBm e.i.r.p.
UMTS	880 - 915 MHz 1920 - 1980 MHz	24 dBm e.i.r.p.
LTE	832 - 862 MHz 880 - 915 MHz 1710 - 1785 MHz 1920 - 1980 MHz 2500 - 2570 MHz	24 dBm e.i.r.p.

DENSO TEN Limited ovime izjavlja da je radijska oprema tipa TN0014D u skladu s Direktivom 2014/53/EU.

Cjeloviti tekst EU izjave o sukladnosti dostupan je na sljedećoj internetskoj adresi:

https://www.denso-ten.com/support/regulation/eu_doc/

Funkcija	Radni frekvencijski pojas	Maksimalna radiofrekvencijska snaga
GSM	880 - 915 MHz 1710 - 1785 MHz	32 dBm e.i.r.p. 30 dBm e.i.r.p.
UMTS	880 - 915 MHz 1920 - 1980 MHz	24 dBm e.i.r.p.
LTE	832 - 862 MHz 880 - 915 MHz 1710 - 1785 MHz 1920 - 1980 MHz 2500 - 2570 MHz	24 dBm e.i.r.p.

Declaration of Conformity

DENSO TEN Limited igazolja, hogy a TN0014D típusú rádióberendezés megfelel a 2014/53/EU irányelvnek.

Az EU-megfelelőségi nyilatkozat teljes szövege elérhető a következő internetes címen:

https://www.denso-ten.com/support/regulation/eu_doc/

Funkció	Üzemi frekvencia-tartomány	Maximális rádiófrekvenciás teljesítmény
GSM	880 - 915 MHz	32 dBm e.i.r.p.
	1710 - 1785 MHz	30 dBm e.i.r.p.
UMTS	880 - 915 MHz	24 dBm e.i.r.p.
	1920 - 1980 MHz	
LTE	832 - 862 MHz	24 dBm e.i.r.p.
	880 - 915 MHz	
	1710 - 1785 MHz	
	1920 - 1980 MHz	
	2500 - 2570 MHz	

Hér með, lýsir DENSO TEN Limited því yfir að gerð útvarpsbúnaðarins TN0014D samræmist tilskipun 2014/53/EU.

Allur texti ESB-samræmisýfirlýsingarinnar er aðgengilegur á eftirfarandi veffangi:

https://www.denso-ten.com/support/regulation/eu_doc/

Aðgerð	Notkunartíðni hljómsveit	Hámarks útvarp-tíðni vald
GSM	880 - 915 MHz	32 dBm e.i.r.p.
	1710 - 1785 MHz	30 dBm e.i.r.p.
UMTS	880 - 915 MHz	24 dBm e.i.r.p.
	1920 - 1980 MHz	
LTE	832 - 862 MHz	24 dBm e.i.r.p.
	880 - 915 MHz	
	1710 - 1785 MHz	
	1920 - 1980 MHz	
	2500 - 2570 MHz	

Declaration of Conformity

Il fabbricante, DENSO TEN Limited, dichiara che il tipo di apparecchiatura radio TN0014D è conforme alla direttiva 2014/53/UE.

Il testo completo della dichiarazione di conformità UE è disponibile al seguente indirizzo Internet:

https://www.denso-ten.com/support/regulation/eu_doc/

Funzione	Frequenza operativa	Massima potenza a radiofrequenza
GSM	880 - 915 MHz 1710 - 1785 MHz	32 dBm e.i.r.p. 30 dBm e.i.r.p.
UMTS	880 - 915 MHz 1920 - 1980 MHz	24 dBm e.i.r.p.
LTE	832 - 862 MHz 880 - 915 MHz 1710 - 1785 MHz 1920 - 1980 MHz 2500 - 2570 MHz	24 dBm e.i.r.p.

Aš, DENSO TEN Limited, patvirtinu, kad radijo įrenginių tipas TN0014D atitinka Direktyvą 2014/53/ES.

Visas ES atitikties deklaracijos tekstas prieinamas šiuo interneto adresu:

https://www.denso-ten.com/support/regulation/eu_doc/

Funkcija	Veikimo dažnių juosta	Maksimalus radijo dažnių galimumas
GSM	880 - 915 MHz 1710 - 1785 MHz	32 dBm e.i.r.p. 30 dBm e.i.r.p.
UMTS	880 - 915 MHz 1920 - 1980 MHz	24 dBm e.i.r.p.
LTE	832 - 862 MHz 880 - 915 MHz 1710 - 1785 MHz 1920 - 1980 MHz 2500 - 2570 MHz	24 dBm e.i.r.p.

Declaration of Conformity

Ar šo DENSO TEN Limited deklarē, ka radioiekārta TN0014D atbilst Direktīvai 2014/53/ES.

Pilns ES atbilstības deklarācijas teksts ir pieejams šādā interneta vietnē:

https://www.denso-ten.com/support/regulation/eu_doc/

Funkcija	Darba frekvences josla	Maksimālā radiofrekvences jauda
GSM	880 - 915 MHz	32 dBm e.i.r.p.
	1710 - 1785 MHz	30 dBm e.i.r.p.
UMTS	880 - 915 MHz	24 dBm e.i.r.p.
	1920 - 1980 MHz	
LTE	832 - 862 MHz	24 dBm e.i.r.p.
	880 - 915 MHz	
	1710 - 1785 MHz	
	1920 - 1980 MHz	
	2500 - 2570 MHz	

Со ова, DENSO TEN Limited изјавува дека радио опремата од типот TN0014D е во согласност со Директивата 2014/53/EU.

Целиот текст на ЕУ изјавата за сообразност е достапен на следната интернет адреса:

https://www.denso-ten.com/support/regulation/eu_doc/

Функција	Работен фреквенциски опсег	Максимална радио-фреквенциска моќ
GSM	880 - 915 MHz	32 dBm e.i.r.p.
	1710 - 1785 MHz	30 dBm e.i.r.p.
UMTS	880 - 915 MHz	24 dBm e.i.r.p.
	1920 - 1980 MHz	
LTE	832 - 862 MHz	24 dBm e.i.r.p.
	880 - 915 MHz	
	1710 - 1785 MHz	
	1920 - 1980 MHz	
	2500 - 2570 MHz	

Declaration of Conformity

Ovim, DENSO TEN Limited izjavljuje da je tip radio opreme TN0014D u skladu sa Direktivom 2014/53/EU.

Cjelokupan tekst EU deklaracije o usklađenosti dostupan je na sljedećoj internet adresi:

https://www.denso-ten.com/support/regulation/eu_doc/

Funkcija	Operativni frekvencijski opseg	Maksimalna jačina radio frekvencije
GSM	880 - 915 MHz	32 dBm e.i.r.p.
	1710 - 1785 MHz	30 dBm e.i.r.p.
UMTS	880 - 915 MHz	24 dBm e.i.r.p.
	1920 - 1980 MHz	
LTE	832 - 862 MHz	24 dBm e.i.r.p.
	880 - 915 MHz	
	1710 - 1785 MHz	
	1920 - 1980 MHz	
	2500 - 2570 MHz	

B'dan, DENSO TEN Limited, niddikjara li dan it-tip ta' tagħmir tar-radju TN0014D huwa konformi mad-Direttiva 2014/53/UE.

It-test kollu tad-dikjarazzjoni ta' konformità tal-UE huwa disponibbli f'dan l-indirizz tal-Internet li ġej:

https://www.denso-ten.com/support/regulation/eu_doc/

Funzjoni	Band tal-frekwenza operattiva	I-enerġija massima bi frekwenza tar-radju
GSM	880 - 915 MHz	32 dBm e.i.r.p.
	1710 - 1785 MHz	30 dBm e.i.r.p.
UMTS	880 - 915 MHz	24 dBm e.i.r.p.
	1920 - 1980 MHz	
LTE	832 - 862 MHz	24 dBm e.i.r.p.
	880 - 915 MHz	
	1710 - 1785 MHz	
	1920 - 1980 MHz	
	2500 - 2570 MHz	

Declaration of Conformity

Hierbij verklaar ik, DENSO TEN Limited, dat het type radioapparatuur TN0014D conform is met Richtlijn 2014/53/EU.
De volledige tekst van de EU-conformiteitsverklaring kan worden geraadpleegd op het volgende internetadres:
https://www.denso-ten.com/support/regulation/eu_doc/

Functie	Actieve frequentieband	Maximale radiofrequentie
GSM	880 - 915 MHz	32 dBm e.i.r.p.
	1710 - 1785 MHz	30 dBm e.i.r.p.
UMTS	880 - 915 MHz	24 dBm e.i.r.p.
	1920 - 1980 MHz	
LTE	832 - 862 MHz	24 dBm e.i.r.p.
	880 - 915 MHz	
	1710 - 1785 MHz	
	1920 - 1980 MHz	
	2500 - 2570 MHz	

DENSO TEN Limited erklærer herved at radioutstyrstypen TN0014D er i samsvar med direktiv 2014/53/EU.

Den fullstendige teksten i EU-erklæringen er tilgjengelig på følgende internetadresse:

https://www.denso-ten.com/support/regulation/eu_doc/

Funksjon	Driftsfrekvensbånd	Maksimal radiofrekvent strøm
GSM	880 - 915 MHz	32 dBm e.i.r.p.
	1710 - 1785 MHz	30 dBm e.i.r.p.
UMTS	880 - 915 MHz	24 dBm e.i.r.p.
	1920 - 1980 MHz	
LTE	832 - 862 MHz	24 dBm e.i.r.p.
	880 - 915 MHz	
	1710 - 1785 MHz	
	1920 - 1980 MHz	
	2500 - 2570 MHz	

Declaration of Conformity

DENSO TEN Limited niniejszym oświadcza, że typ urządzenia radiowego TN0014D jest zgodny z dyrektywą 2014/53/UE.

Pełny tekst deklaracji zgodności UE jest dostępny pod następującym adresem internetowym:

https://www.denso-ten.com/support/regulation/eu_doc/

Funkcja	Pasma częstotliwości pracy	Maksymalna moc częstotliwości radiowej
GSM	880 - 915 MHz 1710 - 1785 MHz	32 dBm e.i.r.p. 30 dBm e.i.r.p.
UMTS	880 - 915 MHz 1920 - 1980 MHz	24 dBm e.i.r.p.
LTE	832 - 862 MHz 880 - 915 MHz 1710 - 1785 MHz 1920 - 1980 MHz 2500 - 2570 MHz	24 dBm e.i.r.p.

O(a) abaixo assinado(a) DENSO TEN Limited declara que o presente tipo de equipamento de rádio TN0014D está em conformidade com a Diretiva 2014/53/UE.

O texto integral da declaração de conformidade está disponível no seguinte endereço de Internet:

https://www.denso-ten.com/support/regulation/eu_doc/

Função	Faixa de frequência operacional	Potência máxima de radiofrequência
GSM	880 - 915 MHz 1710 - 1785 MHz	32 dBm e.i.r.p. 30 dBm e.i.r.p.
UMTS	880 - 915 MHz 1920 - 1980 MHz	24 dBm e.i.r.p.
LTE	832 - 862 MHz 880 - 915 MHz 1710 - 1785 MHz 1920 - 1980 MHz 2500 - 2570 MHz	24 dBm e.i.r.p.

Declaration of Conformity

Prin prezenta, DENSO TEN Limited declară că tipul de echipamente radio TN0014D este în conformitate cu Directiva 2014/53/UE.
Textul integral al declarației UE de conformitate este disponibil la următoarea adresă internet:
https://www.denso-ten.com/support/regulation/eu_doc/

Funcție	Bandă de frecvență activă	Puterea maximă a radio-frecvenței
GSM	880 - 915 MHz 1710 - 1785 MHz	32 dBm e.i.r.p. 30 dBm e.i.r.p.
UMTS	880 - 915 MHz 1920 - 1980 MHz	24 dBm e.i.r.p.
LTE	832 - 862 MHz 880 - 915 MHz 1710 - 1785 MHz 1920 - 1980 MHz 2500 - 2570 MHz	24 dBm e.i.r.p.

DENSO TEN Limited týmto vyhlasuje, že rádiové zariadenie typu TN0014D je v súlade so smernicou 2014/53/EÚ.
Úplné EÚ vyhlásenie o zhode je k dispozícii na tejto internetovej adrese:
https://www.denso-ten.com/support/regulation/eu_doc/

Funkcia	Prevádzkové frekvenčné pásmo	Maximálny rádiový výkon
GSM	880 - 915 MHz 1710 - 1785 MHz	32 dBm e.i.r.p. 30 dBm e.i.r.p.
UMTS	880 - 915 MHz 1920 - 1980 MHz	24 dBm e.i.r.p.
LTE	832 - 862 MHz 880 - 915 MHz 1710 - 1785 MHz 1920 - 1980 MHz 2500 - 2570 MHz	24 dBm e.i.r.p.

Declaration of Conformity

DENSO TEN Limited potruje, da je tip radijske opreme TN0014D skladen z Direktivo 2014/53/EU.

Celotno besedilo izjave EU o skladnosti je na voljo na naslednjem spletnem naslovu:

https://www.denso-ten.com/support/regulation/eu_doc/

Funkcija	Delovni frekvenčni pas	Maksimalna radiofrekvenčna moč
GSM	880 - 915 MHz	32 dBm e.i.r.p.
	1710 - 1785 MHz	30 dBm e.i.r.p.
UMTS	880 - 915 MHz	24 dBm e.i.r.p.
	1920 - 1980 MHz	
LTE	832 - 862 MHz	24 dBm e.i.r.p.
	880 - 915 MHz	
	1710 - 1785 MHz	
	1920 - 1980 MHz	
	2500 - 2570 MHz	

Nëpërmjet kësaj, DENSO TEN Limited deklarom se lloji i aparatit të radios TN0014D është në përputhje me Direktivën 2014/53/EU.

Teksti i plotë i deklaratës së BE-së mbi përputhshmërinë është i disponueshëm në adresën e mëposhtme të internetit:

https://www.denso-ten.com/support/regulation/eu_doc/

Funksion	Banda e frekuencës së punës	Fuqia maksimale e frekuencave radio
GSM	880 - 915 MHz	32 dBm e.i.r.p.
	1710 - 1785 MHz	30 dBm e.i.r.p.
UMTS	880 - 915 MHz	24 dBm e.i.r.p.
	1920 - 1980 MHz	
LTE	832 - 862 MHz	24 dBm e.i.r.p.
	880 - 915 MHz	
	1710 - 1785 MHz	
	1920 - 1980 MHz	
	2500 - 2570 MHz	

Declaration of Conformity

Ovim, DENSO TEN Limited izjavljuje da je ovaj tip radijske opreme TN0014D u skladu sa odredbama Direktive 2014/53/EU.

Kompletan tekst EU deklaracije o konformitetu je dostupan na sledećoj internet adresi:

https://www.denso-ten.com/support/regulation/eu_doc/

Funkcija	Radni frekvencijski pojas	Maksimalna radiofrekvencijska snaga
GSM	880 - 915 MHz	32 dBm e.i.r.p.
	1710 - 1785 MHz	30 dBm e.i.r.p.
UMTS	880 - 915 MHz	24 dBm e.i.r.p.
	1920 - 1980 MHz	
LTE	832 - 862 MHz	24 dBm e.i.r.p.
	880 - 915 MHz	
	1710 - 1785 MHz	
	1920 - 1980 MHz	
	2500 - 2570 MHz	

Härmed försäkrar DENSO TEN Limited att denna typ av radioutrustning TN0014D överensstämmer med direktiv 2014/53/EU.

Den fullständiga texten till EU-försäkran om överensstämmelse finns på följande webbadress:

https://www.denso-ten.com/support/regulation/eu_doc/

Funktion	Operationsfrekvensbandet	Maximal radiofrekvensseffekt
GSM	880 - 915 MHz	32 dBm e.i.r.p.
	1710 - 1785 MHz	30 dBm e.i.r.p.
UMTS	880 - 915 MHz	24 dBm e.i.r.p.
	1920 - 1980 MHz	
LTE	832 - 862 MHz	24 dBm e.i.r.p.
	880 - 915 MHz	
	1710 - 1785 MHz	
	1920 - 1980 MHz	
	2500 - 2570 MHz	

Declaration of Conformity

DENSO TEN Limited, TN0014D türü telsiz ekipmanının 2014/53/EU Direktifine uygun olduğunu beyan etmektedir.

AB uygunluk beyanının tam metnine aşağıdaki internet adresinden ulaşılabilir:

https://www.denso-ten.com/support/regulation/eu_doc/

İşlev	Çalışma frekans bandı	Maksimum radyo-frekans gücü
GSM	880 - 915 MHz	32 dBm e.i.r.p.
	1710 - 1785 MHz	30 dBm e.i.r.p.
UMTS	880 - 915 MHz	24 dBm e.i.r.p.
	1920 - 1980 MHz	
LTE	832 - 862 MHz	24 dBm e.i.r.p.
	880 - 915 MHz	
	1710 - 1785 MHz	
	1920 - 1980 MHz	
	2500 - 2570 MHz	

Declaration of Conformity

Information of the radio device: Type TN0014D

- Name and postal address of the manufacturer
 Name: DENSO TEN Limited
 Address: 2-28, Goshō-dōri 1-chōme, Hyōgo-ku, Kobe, 652-8510 Japan
- Simplified UK declaration of conformity

Hereby, DENSO TEN Limited declares that the radio equipment type TN0014D is in compliance with Regulations 2017.
 The full text of the UK declaration of conformity is available at the following internet address:
https://www.denso-ten.com/support/regulation/uk_doc/

Function	Operating frequency band	Maximum radio-frequency power
GSM	880 - 915 MHz	32 dBm e.i.r.p.
	1710 - 1785 MHz	30 dBm e.i.r.p.
UMTS	880 - 915 MHz	24 dBm e.i.r.p.
	1920 - 1980 MHz	
LTE	832 - 862 MHz	24 dBm e.i.r.p.
	880 - 915 MHz	
	1710 - 1785 MHz	
	1920 - 1980 MHz	
	2500 - 2570 MHz	

Importer Information
Name: Mazda Motors UK Limited
Address: Crossways Business Park, Victory Way, Dartford, Kent, DA2 6DT, UK

Mazda ERA-GLONASS

Нотификация ФСБ № RU0000038283 от 10.07.2018, действительна до 05.07.2023, зарегистрирована ФСБ РФ.

Декларация о соответствии средства связи № Д-МДРТ-11636 от 06.09.2018, действительна до 31.08.2023, зарегистрирована Федеральным агентством связи РФ.

Декларация о соответствии техническому регламенту Таможенного союза 020/2011 № ЕАЭС N RU Д-JP.МЛ26.В.00626 от 30.08.2018, действительна по 29.08.2023, зарегистрирована органом по сертификации продукции АНО «СЦ Связь-сертификат» (аттестат аккредитации RA.RU.11МЛ26, дата регистрации 10.02.2015).

Декларация о соответствии аккумуляторной батарее FT0098A № РОСС RU Д-JP.АД37.В.01289/18 от 24.10.2018, действительна до 23.10.2023, зарегистрирована органом по сертификации продукции «Красно Дар» ООО «ИД Контроль» (аттестат аккредитации RA.RU.11АД37, дата регистрации 03.11.2016).

Wireless Charger (Qi)

Simplified EU Declaration of Conformity :

The simplified EU declaration of conformity referred to in Article 10(9) shall be provided as follows: Hereby, [Huizhou Desay SV Automotive Co., Ltd.] declares that the radio equipment type [designation of type of radio equipment] is in compliance with Directive 2014/53/EU. The full text of the EU declaration of conformity is available at the following internet address:<http://www.desaysv.com/index.php?id=oumeng>

Max power transmitter(Wireless Charging) : 15W
Operating Frequency: 127.7KHz、125.95KHz
NFC Operating Frequency:13.56Mhz
Maximum RF Output Power(NFC) : 6.48 dBuA/m at 3m distance

Importer, Address:
İthalatçı, Adres:
İmportuesi, Adresa:

Mazda Motor Logistics Europe NV
Blaasveldstraat 162, 2830 Willebroek, België

Mazda Motor Poland sp.zo.o.
ul. Postępu 14B, 02-676 Warsaw, Poland

Mazda Motor Czech, s.r.o.
Tůrkova 2319/5b, Chodov, 149 00 Prague 4, Czech Republic

Mazda Motor Slovakia, s.r.o.
LINDNER II, Galvaniho 7/B, Bratislava - Ružinov 821 04, Slovak Republic

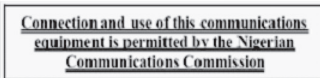

Nigeria

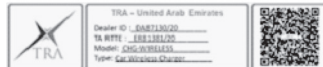

UAE (United Arab Emirates)

For more certification marks, please see the product label.

Taiwan **RoHS** 含有物質標識表，請至下列網址查閱：<https://www.desaysv.com/index.php?id=twrohs>

台灣NCC 警語：低功率電波輻射性電機管理辦法 第十二條 經型式認證合格之低功率射頻電機，非經許可，公司、商號或使用者均不得擅自變更頻率、加大功率或變更原設計之特性及功能。第十四條 低功率射頻電機之使用不得影響飛航安全及干擾合法通信；經發現有干擾現象時，應立即停用，並改善至無干擾時方得繼續使用。前項合法通信，指依電信法規定作業之無線電通信。低功率射頻電機須忍受合法通信或工業、科學及醫療用電波輻射性電機設備之干擾。商標：Mazda

Electromagnetic Compatibility

Electromagnetic Compatibility

Your Mazda has been tested and certified to the UN-R*¹ 10 regulation as related to electromagnetic compatibility. Radio Frequency (RF) transmitter equipment (e.g. cellular telephones, amateur radio transmitters, etc.) may only be fitted to your Mazda if they comply with the parameters shown in the table below.

*1 UN-R stands for United Nations Regulation.

It is your responsibility to ensure that any equipment you have fitted complies with applicable local legislations. Have any equipment fitted by properly trained technicians.

⚠ CAUTION

- Do not mount any transceiver, microphones, speakers, or any other item in the deployment path of the air bag system.
- Do not fasten aerial lead to original vehicle wiring, fuel pipes or brake pipes. Avoid running the aerial lead parallel with the wire harness to the best extent possible.
- Keep the aerial and power leads at least 100 mm (3.9 in) from any electronic modules and the air bags.
- Avoid using the cigar lighter or accessory socket as a power source for the RF-transmitting equipment.

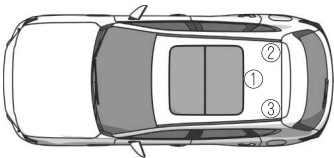

Aerial positions:

- ①: Centre of roof
- ②: Rear right of roof
- ③: Rear left of roof

Frequency Band (MHz)	Maximum output power (Wattage)	Aerial Positions
50 — 54	50	①②③
68 — 87.5	50	①②③
142 — 176	50	①②③
380 — 470	50	①②③
806 — 940	10	①②③
1200 — 1300	10	①②③
1710 — 1885	10	①②③
1885 — 2025	10	①②③
2400 — 2500	0.01* ¹	In a cabin* ¹

*1 Only for Bluetooth®

NOTE

After the installation of RF transmitters, check for disturbances from and to all electrical equipment in the vehicle, both in the standby and transmit modes.

Check all electrical equipment:

- with the vehicle power ON.
- with the engine operating.
- during a road test at various speeds.

Collection/Disposal of Old Equipment/Used Battery

Information for Users on Collection and Disposal of Old Equipment and Used Batteries

When disposing your old battery, please refer to the information as follows.

Information on Disposal in the European Union

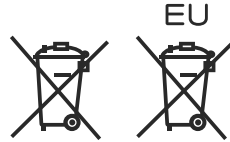

These crossed-out wheeled bin symbols on the products, packaging, and/or accompanying documents mean that used electronic products and batteries should not be mixed with general household waste. For proper treatment, recovery and recycling of old products and used batteries, please take them to applicable collection points, in accordance with your national legislation and the Directives 2006/66/EC.

By disposing of these products and batteries correctly, you will help to save valuable resources and prevent any potential negative effects on human health and the environment which could otherwise arise from inappropriate waste handling.

For more information about collection and recycling of old products and batteries, please contact your local municipality, your waste disposal service or the point of sales where you purchased the items.

NOTE



The bottom two letters might be used in combination with the crossed-out wheeled bin symbol. In this case it complies with the requirement established by the Directive for the chemical involved.

"Pb" and "Cd" mean lead and cadmium respectively.

Information on Disposal in Other Countries Outside the European Union

The above symbols are only valid in the European Union. If you wish to discard old products and used batteries, please contact your local authorities, your waste disposal service or the point of sales where you purchased the items, and ask for the correct method of disposal.

Vehicle Identification Number (South Africa, Arab Gulf Cooperation Council, Iraq, Ghana)

The vehicle identification number legally identifies your vehicle. The number is on a plate attached to the left top side of the instrument panel. This plate can easily be seen through the windscreen.

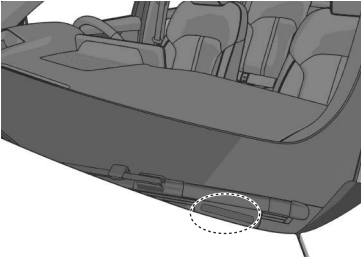

Model Plate

Vehicles assembled in any country other than the Russian Federation

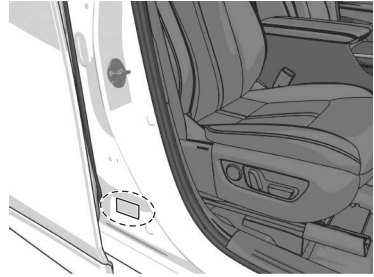

Vehicles assembled in Russian Federation

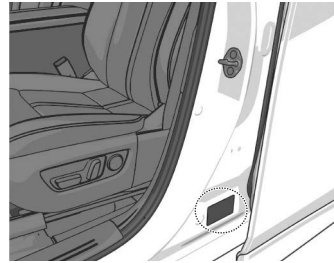

Identification Numbers

Chassis Number/Vehicle Identification Number

Chassis Number

Open the cover shown in the figure to check the chassis number.



Vehicle Identification Number

Ireland, UK, Cyprus, Malta,
Swaziland, Namibia, Botswana,
Lesotho, Kazakhstan, Armenia,
Russia, Belarus

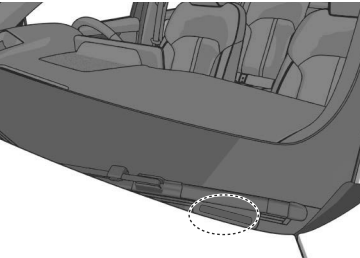

Vehicles assembled in Russian Federation

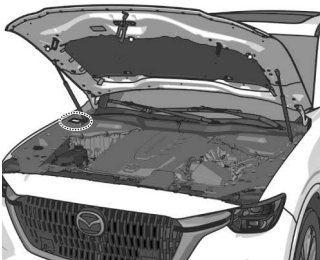

Vehicle Emission Control Information Label (Philippines)

Philippines

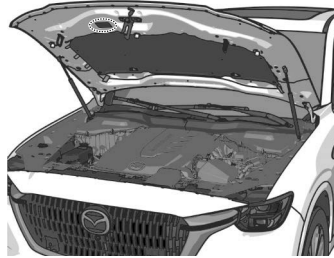

Tyre Pressure Label

Left-hand drive model



Right-hand drive model

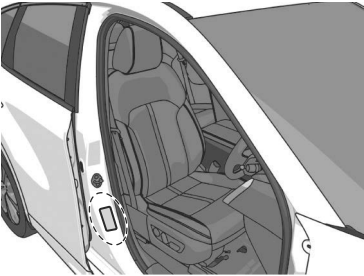

Engine Number

SKYACTIV-G

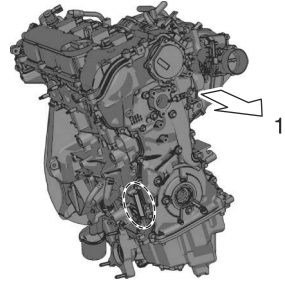

1. Forward
e-SKYACTIV G

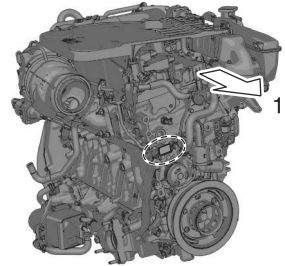

1. Forward
e-SKYACTIV D

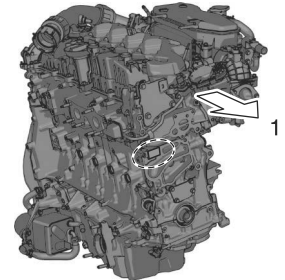

1. Forward

Identification Numbers

Conformity Plate (Arab Gulf Cooperation Council, Iraq)

Production year and month are shown on this plate.

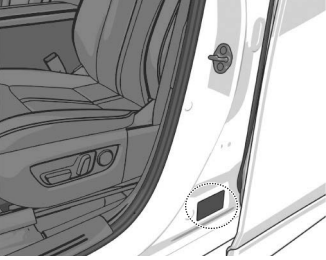

Engine

Petrol engine

Item	SKYACTIV-G	e-SKYACTIV G
Type	DOHC-16V in-line, 4-cylinder	DOHC-24V in-line, 6-cylinder
Bore × Stroke	89.0 × 100.0 mm (3.50 × 3.94 in)	86.0 × 94.2 mm (3.39 × 3.71 in)
Displacement	2,488 ml (2,488 cc)	3,283 ml (3,283 cc)
Compression ratio	13.0	12.0

Arab Gulf Cooperation Council

Item	SKYACTIV-G	
	RWD	AWD
Maximum engine power/ revolution	141 kW/6,000 rpm	141 kW/6,000 rpm
Maximum engine torque/ revolution	261 N·m/3,000 rpm	261 N·m/3,000 rpm
Maximum speed	203 km/h (126 mph)	201 km/h (125 mph)

Item	e-SKYACTIV G
Maximum engine power/ revolution	209 kW/5,000 rpm — 6,000 rpm
Maximum engine torque/ revolution	450 N·m/2,000 rpm — 3,500 rpm
Maximum speed	219 km (136 mph)

Diesel engine

Item	e-SKYACTIV D
Type	DOHC-24V in-line, 6-cylinder
Bore × Stroke	86.0 × 94.2 mm (3.39 × 3.71 in)
Displacement	3,283 ml (3,283 cc)
Compression ratio	15.2

Vehicle Specification

Mazda M Hybrid Boost Battery (e-SKYACTIV D)

Item	Specification
Type	Lithium-ion battery
Temperature range	Operation guaranteed temperature: -30°C (-22°F) — 65°C (149°F) Storage guaranteed temperature: -40°C (-40°F) — 80°C (176°F)

Electrical System

Lead-acid battery*¹

Classification		Specification
SKYACTIV-G	With i-stop	Q-85
	Without i-stop	55D23L (12V-60Ah/20HR) or 75D23L (12V-65Ah/20HR)
e-SKYACTIV G		75D23L (12V-65Ah/20HR) or 80D26L (12V-65Ah/20HR)
e-SKYACTIV D		S-95 or 80D26L (12V-65Ah/20HR)

*1 The battery specification differs depending on the country or region. Check the battery installed on the vehicle and use a battery with an equal or higher performance. However, the performance of the battery may vary even among the same battery types, consult an expert repairer (we recommend an Authorised Mazda Repairer) for replacement.

Spark-plug

Classification	Specification	
SKYACTIV-G	Mazda Genuine spark plug* ¹	PE5R-18-110-A or PE5S-18-110
e-SKYACTIV G	Mazda Genuine spark plug* ¹	H301-18-110

*1 This spark plug provides the SKYACTIV-G, e-SKYACTIV G engine with optimum performance. Consult an expert repairer (we recommend an Authorised Mazda Repairer) for details.



When cleaning the iridium plugs, do not use a wire brush. The fine particulate coating on the iridium alloy and platinum tips could be damaged.

Lubricant Quality

Engine oil	Europe and Taiwan	Except Europe and Taiwan
SKYACTIV-G	Recommended Oils* ¹	Oil Quality
	Mazda Original Oil Supra-X 0W-20	API SL or higher
	Mazda Original Oil Ultra 5W-30	
	Alternative Oil Quality* ²	
	API SN* ³ or higher, or ACEA A5/B5	
e-SKYACTIV G	Recommended Oils* ¹	Oil Quality
	Mazda Original Oil Supra-X 0W-20	API SN or higher
	Mazda Original Oil Ultra 5W-30	
	Alternative Oil Quality* ²	
	API SN* ³ or higher, or ACEA A5/B5	
e-SKYACTIV D	Recommended Oils* ¹	Oil Quality
	Mazda Original Oil Ultra DPF 5W-30	ACEA C3 0W-30/5W-30
	Mazda Original Oil Supra DPF 0W-20	
	Mazda Original Oil Supra DPF 0W-30	
	Alternative Oil Quality* ²	
	ACEA C3	

*¹ Mazda Original Oils are specially designed/tested for the respective engine. For optimum performance we recommend to use Mazda Original Oils at all times.

*² If you are unable to find a Mazda Original Oil, alternative oils meeting the listed specification may also be used.

Do not use oils which do not meet the above specification or requirements. Use of unsuitable oil may lead to engine damage which is not covered by the Mazda Warranty.

Lubricant	Classification
Coolant	FL-22 type
Automatic transmission fluid* ¹	Mazda Original Oil ATF-A7
Transfer case oil* ²	
Front differential oil* ²	Mazda Long Life Hypoid Gear Oil SG1
Rear differential oil* ²	

Lubricant		Classification
Brake	e-SKYACTIV G, e-SKYACTIV D	Mazda Genuine Brake Fluid or equivalent
	SKYACTIV-G	SAE J1703 or FMVSS116 DOT-3 or DOT-4

*1 Periodic replacement is unnecessary.

*2 Replacement is necessary when the component is submerged in water.

Vehicle Specification

Cleaner

Cleaner	Classification
Deposit Cleaner*1	Mazda genuine deposit cleaner (K002 W0 001 A)

*1 Use Mazda genuine deposit cleaner. Using non-genuine deposit cleaner would cause internal failure of the fuel system. Refer to 5-124, 9-6 for the details.

Capacities

(Approximate Quantities)

Item		Left-hand drive model	Right-hand drive model
Engine oil	SKYACTIV-G	With oil filter replacement	4.5 L (4.8 US qt, 4.0 Imp qt)
		Without oil filter replacement	4.3 L (4.5 US qt, 3.8 Imp qt)
	e-SKYACTIV G	With oil filter replacement	6.0 L (6.3 US qt, 5.3 Imp qt)
		Without oil filter replacement	5.7 L (6.0 US qt, 5.0 Imp qt)
	e-SKYACTIV D	With oil filter replacement	6.5L (6.9 US qt, 5.7 Imp qt)
		Without oil filter replacement	6.2L (6.6 US qt, 5.5 Imp qt)
Coolant	SKYACTIV-G	For engine	6.9 L (7.3 US qt, 6.1 Imp qt) 7.0 L (7.4 US qt, 6.2 Imp qt)
		For water-cooled charge air cooler	3.6 L (3.8 US qt, 3.2 Imp qt)
	e-SKYACTIV G	For engine	9.3 L (9.8 US qt, 8.2 Imp qt) 10.2 L (10.8 US qt, 8.97 Imp qt)
		For water-cooled charge air cooler	5.4 L (5.7 US qt, 4.8 Imp qt)
	e-SKYACTIV D	For engine	8.5 L (9.0 US qt, 7.5 Imp qt) 9.4 L (9.9 US qt, 8.3 Imp qt)
		For water-cooled charge air cooler	5.8 L (6.1 US qt, 5.1 Imp qt)

Specifications/Customer Information
Vehicle Specification

Automatic transmission fluid	SKYACTIV-G		8.3 L (8.8 US qt, 7.3 Imp qt)
	e-SKYACTIV G		8.5 L (9.0 US qt, 7.5 Imp qt)
	e-SKYACTIV D	With Selective Catalytic Reduction (SCR) System	8.3 L (8.8 US qt, 7.3 Imp qt)
		Without Selective Catalytic Reduction (SCR) System	8.5 L (9.0 US qt, 7.5 Imp qt)
Transfer case oil		Europe	0.54 L (0.57 US qt, 0.48 Imp qt)
		Except Europe	0.51 L (0.54 US qt, 0.45 Imp qt)
Front differential oil			0.35 L (0.37 US qt, 0.31 Imp qt)
Rear differential oil		SKYACTIV-G	0.80 L (0.85 US qt, 0.70 Imp qt)
		e-SKYACTIV G , e-SKYACTIV D	0.90 L (0.95 US qt, 0.79 Imp qt)
Fuel tank			58.0 L (15.3 US gal, 12.8 Imp gal)

Check oil and fluid levels with dipsticks or reservoir gauges.

Dimensions

Item		18 inch wheel vehicle	20 inch wheel vehicle
Overall length	With number plate holder	4,745 mm (186.8 in)	
	Without number plate holder	4,740 mm (186.6 in)	
Overall width		1,890 mm (74.4 in)	
Overall height		1,675 mm (65.9 in)	1,680 mm (66.1 in)
Front tread		1,640 mm (64.5 in)	
Rear tread		1,645 mm (64.7 in)	
Wheelbase		2,870 mm (113.0 in)	

Light Bulbs

Exterior light/Interior light

All the light bulbs are the LED type.

The LED bulb cannot be replaced as a single unit because it is an integrated unit.

The LED bulb has to be replaced with the unit. If a replacement is necessary, consult an expert repairer (we recommend an Authorised Mazda Repairer).

Tyres

Sample tyre mark and its meaning

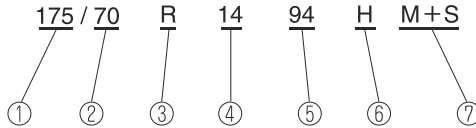

1. Nominal section width
2. Nominal aspect ratio in %
3. Construction code
4. Nominal rim diameter in inches
5. Load index (not on ZR tyres)
6. Speed symbol
7. Mud and snow

Tyre mark information

Choose the proper tyres for your vehicle using the following tyre mark information.

Speed symbol	Maximum permissible speed
Q	Up to 160 km/h (99 mph)
R	Up to 170 km/h (105 mph)
S	Up to 180 km/h (111 mph)
T	Up to 190 km/h (118 mph)
U	Up to 200 km/h (124 mph)
H	Up to 210 km/h (130 mph)
V	Up to 240 km/h (149 mph)
W	Up to 270 km/h (167 mph)
Y	Up to 300 km/h (186 mph)
ZR	Over 240 km/h (149 mph)

Tyre and inflation pressure

NOTE

The tyres have been optimally matched with the chassis of your vehicle. When replacing tyres, Mazda recommends that you replace tyres of the same type originally fitted to your vehicle. For details, contact an expert repairer (we recommend an Authorised Mazda Repairer).

Check the tyre pressure label for tyre size and inflation pressure. Refer to Tyre Pressure Label on page 10-79.

Standard tyre

Tyre size		Inflation pressure	
		Up to 3 persons	—Full load
235/60R18 103V	Front	250 kPa (2.5 bar, 36 psi)	270 kPa (2.7 bar, 39 psi)
	Rear	250 kPa (2.5 bar, 36 psi)	310 kPa (3.1 bar, 45 psi)
235/60R18 107V	Front	250 kPa (2.5 bar, 36 psi)	270 kPa (2.7 bar, 39 psi)
	Rear	250 kPa (2.5 bar, 36 psi)	310 kPa (3.1 bar, 45 psi)
235/50R20 100W	Front	250 kPa (2.5 bar, 36 psi) ^{*1}	270 kPa (2.7 bar, 39 psi)
	Rear	250 kPa (2.5 bar, 36 psi) ^{*1}	310 kPa (3.1 bar, 45 psi)
235/50R20 104W	Front	250 kPa (2.5 bar, 36 psi)	270 kPa (2.7 bar, 39 psi)
	Rear	250 kPa (2.5 bar, 36 psi)	310 kPa (3.1 bar, 45 psi)

Single occupant's weight: About 75 kg

^{*1} Before driving at high speeds, increase the pressure of the tyres. For speeds above 160 km/h (99.4 mph), increase the pressure of the tyres by 10 kPa (0.1 bar, 1.5 psi).

After high-speed driving, returning to standard tyre pressure is recommended.

Temporary spare tyre^{*}

Tyre size	Inflation pressure
T155/90D18 113M	420 kPa (4.2 bar, 60 psi)

Winter tyre

Tyre size		Inflation pressure	
		Up to 3 persons	—Full load
235/60R18 ^{*1} M+S	Front	250 kPa (2.5 bar, 36 psi)	270 kPa (2.7 bar, 39 psi)
	Rear	250 kPa (2.5 bar, 36 psi)	310 kPa (3.1 bar, 45 psi)
235/50R20 ^{*2} M+S	Front	250 kPa (2.5 bar, 36 psi)	270 kPa (2.7 bar, 39 psi)
	Rear	250 kPa (2.5 bar, 36 psi)	310 kPa (3.1 bar, 45 psi)

Single occupant's weight: About 75 kg

^{*1} Load index and speed symbol: 103Q/103S/103T/103H/103V

^{*2} Load index and speed symbol: 100Q/100S/100T/100H/100V/100W/104Q/104S/104T/104H/104V/104W

Wheel nut tightening torque

When installing a tyre, tighten the wheel nut to the following torque.
 108—147 N·m (12—14 kgf·m, 80—108 ft·lbf)

Brakes

If you require information regarding the wear limit specification for the brake disc plates and the measurement method, please contact an expert repairer (we recommend an Authorised Mazda Repairer). The information is made freely available.

MEMO

Index

A

- Active Driving Display.....5-52
 - Active driving display does not operate..... 8-38
 - Maintenance of the dust-proof sheet..... 9-64
- Air Bags.....3-2
 - Front passenger occupant classification system.....3-13
- Air-Conditioning
 - Air vents..... 6-2
 - Air-conditioning overview..... 6-6
 - Maintenance..... 9-57
 - Operating each switch..... 6-7
- Automatic Transmission
 - Selector lever..... 5-56
 - Steering shift switches..... 5-60
- AWD
 - i-ACTIV AWD..... 5-109

B

- Battery
 - Electrical system..... 10-83
 - Inspecting Lead-acid battery..... 9-41
 - Taking action with depleted lead-acid battery..... 8-11
- Bonnet..... 4-27
- Brakes
 - Antilock Brake System (ABS)..... 5-95
 - AUTOHOLD..... 5-73
 - AUTOHOLD cannot be cancelled..... 8-19
 - Brakes..... 10-93
 - Brake override system..... 5-71
 - Dynamic Stability Control (DSC)..... 5-99
 - Electric Parking Brake (EPB)....5-67

- Emergency Signal System (ESS).....5-77
- Hill descent control..... 5-103
- Hill Launch Assist (HLA)..... 5-76
- Inspecting the brake fluid..... 9-39
- Problem with the brake system (foot brake).....8-18
- Traction Control System (TCS)..... 5-96
- Trailer Stability Control (TSC)..... 5-101

C

- Cruise Control..... 5-254

D

- Doors
 - Doors..... 4-12
 - Liftgate.....4-18

E

- Engine
 - Engine.....10-81
 - Engine cannot be stopped..... 8-17
 - Engine number..... 10-79
 - Inspecting the coolant..... 9-37
 - Inspecting/replenishing engine oil.....9-33
 - i-stop.....5-23
 - Overheating..... 8-20
 - Push button start..... 5-15
 - Starting a flooded engine..... 8-16
 - Taking action with depleted lead-acid battery.....8-11

I

- Inspection and Maintenance
 - Air conditioner maintenance..... 9-57

- Capacities..... 10-87
- Chassis Number/Vehicle Identification Number..... 10-78
- Cleaner..... 10-86
- Dimensions..... 10-89
- Lubricant quality..... 10-84
- Model plate..... 10-77
- Inspection and Servicing
 - Body lubrication..... 9-47
 - Brake fluid..... 9-39
 - Coolant..... 9-37
 - Emergency flat tyre repair kit..... 9-55
 - Engine oil..... 9-33
 - Fuses..... 9-44
 - Inspecting the tyres..... 9-52
 - Inspection and servicing..... 9-4
 - Lead-acid battery..... 9-41
 - Light bulbs..... 9-55
 - Replacing a tyre or a wheel.... 9-54
 - Rotating the tyres..... 9-53
 - Scheduled maintenance..... 9-5
 - Windscreen washer fluid..... 9-40
 - Windscreen wiper blade rubbers..... 9-48
- Instrument Cluster
 - Warning/Indicator light turns on..... 8-39
- Instrument Cluster (Type A)
 - Average fuel economy display..... 5-35
 - Deceleration regeneration charge display..... 5-36
 - Engine coolant temperature gauge..... 5-31
 - Fuel gauge..... 5-32
 - Instantaneous fuel economy display..... 5-36
 - Instrument cluster..... 5-26
 - Instrument panel illumination..... 5-32
- i-ACTIVSENSE status symbol (Warning/Risk avoidance support system)..... 5-38
- Maximum driving distance display..... 5-34
- Message display..... 5-38
- Odometer/Trip meter..... 5-30
- Outside temperature display..... 5-34
- Remaining AdBlue® and maximum driving distance display..... 5-37
- Speedometer..... 5-29
- Tachometer..... 5-30
- Vehicle Speed Alarm..... 5-37
- Instrument Cluster (Type B)
 - Average fuel economy display..... 5-48
 - Deceleration regeneration charge display..... 5-49
 - Engine coolant temperature gauge..... 5-44
 - Fuel gauge..... 5-45
 - Instantaneous fuel economy display..... 5-49
 - Instrument cluster..... 5-39
 - Instrument panel illumination..... 5-45
 - i-ACTIVSENSE display..... 5-51
 - Maximum driving distance display..... 5-47
 - Message display..... 5-51
 - Multi-information display..... 5-41
 - Odometer/Trip meter..... 5-43
 - Outside temperature display..... 5-47
 - Remaining AdBlue® and maximum driving distance display..... 5-50
 - Speedometer..... 5-39
 - Tachometer..... 5-40
 - Vehicle speed alarm..... 5-50
- Interior Equipment

Index

Accessory sockets..... 7-64
AC power outlet (220 V/150 W)..... 7-65
Centre console..... 7-53
Cup holders..... 7-49
Illuminated entry system..... 7-59
Luggage compartment..... 7-56
Luggage compartment cover..... 7-76
Map lights..... 7-61
Overhead lights..... 7-60
Partition net..... 7-78
Sunvisor..... 7-57
USB power outlet..... 7-68
Vanity mirrors..... 7-58
Wireless charger (Qi)..... 7-70

i-ACTIVSENSE

Adaptive LED Headlights (ALH)..... 5-150
Adjustable Speed Limiter (ASL)..... 5-214
Blind Spot Monitoring (BSM)..... 5-158
Cameras..... 5-143
Cruising & Traffic Support (CTS)..... 5-192
Distance & Speed Alert (DSA)..... 5-166
Driver Attention Alert (DAA)..... 5-168
Driver monitoring camera... 5-145
Driver Monitoring (DM)..... 5-170
Emergency Lane Keeping (ELK)..... 5-220
Forward Sensing Camera (FSC)..... 5-133
Front Cross Traffic Alert (FCTA)..... 5-174
High Beam Control System (HBC)..... 5-146

Intelligent Speed Assistance (ISA)..... 5-217
i-ACTIVSENSE OFF switch... 5-132
i-ACTIVSENSE status symbol (Warning/risk avoidance support system)..... 5-130
Lane Departure Warning System (LDWS)..... 5-155
Lane-keep Assist System (LAS)..... 5-211
Mazda Radar Cruise Control (MRCC)..... 5-179
Radar sensors..... 5-137
Rear Cross Traffic Alert (RCTA)..... 5-177
Secondary Collision Reduction..... 5-252
Smart Brake Support (SBS)... 5-226
Traffic Sign Recognition System (TSR)..... 5-163
360° View Monitor..... 5-235

K

Key..... 4-5
 Cancelling the key temporary suspension function..... 8-8
 Replacing the key battery..... 9-58
 Starting the Engine with a dead battery key..... 8-9
 Unlocking using the auxiliary key..... 8-8

L

Liftgate..... 4-18
 Liftgate cannot open..... 8-33
 Power liftgate..... 4-21
Light
 Washer fluid does not spray... 8-37
Lights
 Direction indicator lever..... 5-83

- Hazard warning lights..... 5-93
- Light bulbs..... 10-90
- Light switch..... 5-78
- Replacing light bulbs..... 9-55

M

Maintenance

- Dust-proof sheet of the active driving display..... 9-64
- Exterior..... 9-60
- Instrument panel..... 9-62
- Interior..... 9-62
- Leather upholstery..... 9-63
- Seat belts..... 9-65
- Upholstery and synthetic leather..... 9-63
- Wheel..... 9-61

Mazda Connect

- Audio remote control switch..... 7-12
- Commander switch..... 7-8
- Mazda connect..... 7-4
- Voice recognition function..... 7-15

Mazda intelligent Drive Select (Mi-Drive)..... 5-106

Mazda M Hybrid Boost

- Mazda M Hybrid Boost..... 5-18
- Mazda M Hybrid Boost Battery..... 10-82
- Push button start..... 5-15

Mirrors

- Mirror defogger..... 5-90
- Outside mirrors..... 5-11
- Rearview mirror..... 5-14

P

Panorama Sunroof

- The panorama sunroof cannot be operated..... 8-35

Parking Sensor..... 5-263

R

- Rear View Monitor..... 5-258
- Refuelling..... 5-120
 - Fuel requirements..... 5-122

S

Seats

- Child-restraint systems..... 3-40
- Driving Position Memory..... 3-27
- Front seats..... 3-25
- Leather upholstery maintenance..... 9-63
- Rear seats..... 3-32
- Seat ventilation..... 6-17
- Seat warmer..... 6-12
- Upholstery and synthetic leather maintenance..... 9-63
- Seat Belts..... 3-17
 - Maintenance..... 9-65
- Security System..... 4-34
 - Immobilizer system..... 4-36
 - Theft-Deterrent System..... 4-38
- Steering Wheel
 - Heated steering wheel..... 6-15
 - Power steering..... 5-110
 - Steering shift switches..... 5-60
- Sunroof
 - Panorama sunroof..... 4-32

T

Towing

- Having the vehicle towed..... 8-5
- Using the towing hooks..... 8-6
- Turbocharged vehicles..... 5-272

Tyres

- Emergency flat tyre repair kit..... 8-22
- Inspecting the emergency flat tyre repair kit..... 9-55

Index

Inspecting the tyres.....	9-52
Replacing a tyre or a wheel....	9-54
Rotating the tyres.....	9-53
Tyres.....	10-91
Tyre pressure label.....	10-79
Tyre Pressure Monitoring System (TPMS).....	5-111
Wheel maintenance.....	9-61

W

Warranty.....	10-2
Window	
Power window.....	4-29
Rear window defogger switch.....	5-89
The power windows cannot be operated.....	8-34
Windscreen wiper de-icer.....	5-91
Wipers	
Replacing windscreen wiper blade rubbers.....	9-48
Replenishing windscreen washer fl uid.....	9-40
Washer fluid does not spray...	8-37
Windscreen wipers operate at high speed.....	8-36
Windscreen wiper de-icer.....	5-91
Windscreen wiper/Washer switch.....	5-84

